

The Office /  
Home Office Collections







The Office / Home-Office  
Collections



# The Office / Home-Office Collections

## Main Index

**COLLEZIONE UFFICIO**  
**OFFICE COLLECTIONS**  
エグゼクティブシステムズ  
扶椅办公室

**6** Office Collections  
→

**200** Office chairs  
→

**276** Multifunctional chairs  
→

**COLLEZIONI HOME-OFFICE**  
**HOME-OFFICE COLLECTIONS**  
ホームオフィスコレクション  
家庭办公室收藏

**314** Chairs and Small  
Armchairs  
→

**332** Tables and Desks  
→

**352** Bookcases  
→

**364** Technical Drawings  
→

**MATERIA E COLORE**  
**MATERIALS AND COLOURS**  
物質と色  
物质和颜色

**378** Pelle Frau®  
→

**390** Fabrics  
→

**399** Woods / Marbles / Stones /  
Fenix® / Ginger Ale shell  
→



## A

Archibald chair 316 — 366

## C

C.E.O. Cube 72 — 96  
Chancellor 218 — 225  
Cercle 202 — 217  
Cockpit 226 — 237  
Chancellor Conference 278 — 281

## D

DownTown 238 — 247  
DownTown Conference 282 — 287  
Donald 320 — 366

## F

Forum 248 — 255  
Fred 334 — 369

## G

Ginger Ale 256 — 266  
326 — 367  
Ginger 322 — 366

## H

H\_O 102 — 113

## I

Iren 336 — 369

## J

Jobs 12 — 64  
Jobs bookcase 54 — 69  
354 — 371

## L

Lloyd 358 — 371

## M

Mesa Due Meeting Table 114 — 120  
Movie 288 — 291  
Mesa Due 340 — 369

## O

Oxford 268 — 275

## P

Peek-a-Book 344 — 370

## R

Ren Bookcase 362 — 374

## S

Segreto 350 — 370

## T

Trust 124 — 170  
THF 292 — 295







## Part 1

# The Office Index

### COLLEZIONE UFFICIO OFFICE COLLECTION エグゼクティブシステムズ 扶椅办公室

- 12** Jobs  
→ Rodolfo Dordoni
- 72** C.E.O. Cube  
→ Lella and Massimo Vignelli
- 102** H\_0  
→ Claudio Silvestrin
- 114** Mesa Due Meeting Table  
→ Lella and Massimo Vignelli
- 124** Trust  
→ Lievore - Altherr - Park

### POLTRONE UFFICIO OFFICE ARMCHAIRS オフィス用アームチェア 领导体系

- 202** Cercle  
→ Lievore-Altherr-Park
- 218** Chancellor  
→ Lievore-Altherr-Molina
- 226** Cockpit  
→ Ferrari Design Centre  
Poltrona Frau
- 238** DownTown  
→ Jean-Marie Massaud
- 248** Forum  
→ Poltrona Frau  
Style & Design Centre
- 256** Ginger Ale  
→ Roberto Lazzeroni
- 268** Oxford  
→ Poltrona Frau  
Style & Design Centre

### POLTRONE CONFERENZA CONFERENCE ARMCHAIRS 会議場用アームチェア 会议扶手椅

- 278** Chancellor Conference  
→ Lievore-Altherr-Molina
- 282** DownTown Conference  
→ Jean-Marie Massaud
- 288** Movie  
→ Mario Marengo
- 292** THF  
→ Lievore-Altherr-Molina



# The Poltrona Frau Office

## L'UFFICIO COME RACCONTO ABITATIVO

L'articolata collezione di Poltrona Frau trova espressione in numerosi cataloghi, diversi per contenuto tipologico ma omogenei nella filosofia. Tutto muove dalla volontà di creare ambienti raffinati e confortevoli in cui l'essere umano possa vivere piacevolmente i diversi momenti della giornata. La matrice originaria della visione di Poltrona Frau è senz'altro da individuare nell'ambiente domestico e, più precisamente, in una sofisticata idea di comfort secondo la quale le scelte materiche e di dettaglio sono in grado di condurre ciascun abitante in una dimensione rigorosa ed esclusiva. Infatti, seguendo la grande tradizione italiana del saper fare, Poltrona Frau è certa che la nobiltà dei materiali impiegati e l'accuratezza delle procedure realizzative si ponga di per sé come garanzia per la nobiltà del risultato compositivo finale. Chi si sia abituato, stando seduto in un'invitante poltrona o sdraiato su un confortevole divano, al quel tipo di ineguagliabili sensazioni tattili e percettive offerte da Poltrona Frau difficilmente potrà accettare, una volta giunto nel suo ambiente di lavoro, un livello di "ospitalità" inferiore. Per questo, quasi spontaneamente, nel corso di oltre 100 anni di storia è nato "L'Ufficio" di Poltrona Frau. La stessa morbida accoglienza, la stessa perfetta definizione dei dettagli, la stessa matericità che declina pelli sceltissime abbinandole a preziose essenze lignee, a metalli dalle finiture ricercate e a preziosi marmi e pietre e inoltre una gamma di finiture e abbinamenti talmente ampia da garantire una personalizzazione praticamente infinita, consentono di far transitare chi è abituato alla unicità della casa Poltrona Frau in un ambiente ufficio assolutamente adeguato e altrettanto unico. Il sapiente uso della Pelle Frau® in particolare, da sempre garanzia di qualità e durata, introduce nei sistemi direzionali una caratteristica veramente rara nel mondo dell'ufficio.

## THE OFFICE AS A HOUSING TALE

The highly diversified Poltrona Frau collection is divided into a large number of catalogues, different in content yet all sharing the same philosophy. Their underlying common denominator is a desire to create elegant and comfortable rooms that can be enjoyed at any time of day. The roots of the Poltrona Frau vision are to be found in the home and, more specifically, in a sophisticated idea of comfort where the choice of material and detail takes users into an exclusive, discerning dimension. True to the great tradition of Italian savoir-faire, Poltrona Frau is certain that the excellence of its materials and precision of its production processes guarantee the excellence of the final effect. Anyone accustomed to the unparalleled tactile and perceptual qualities offered by Poltrona Frau when sitting in a cosy armchair or lying on a comfortable sofa, will find it difficult to accept a lower level of "hospitality" at work. This is why Poltrona Frau "Office" emerged almost spontaneously during the company's 100 years plus of history. People used to the uniqueness of a Poltrona Frau home can in this way enjoy the same total satisfaction and uniqueness in the workplace, with the same comfort, the same perfect definition of details, and the same material aspect that combines carefully selected leathers with fine woods or metals in sophisticated finishes or precious marble and stone, plus a range of finishes and combinations diverse enough to guarantee practically infinite customisation. Skilful use of Pelle Frau® leather in particular, always a guarantee of quality and durability, introduces into management systems a feature that is truly rare in the office environment.

## ザ・オフィスはライフ・スタイルの表現

ポルトローナ・フラウは多岐に亘るコレクションのカタログを家具の分野別にご用意していますが、基本となるフィロソフィーは一貫しています。日々の暮らしの中のどの時間帯でも、快適にお過ごしいただけるよう、洗練された心地よい環境を生み出す事を目指しているのです。高級で、精度の高いお住まいを造り出すために素材を厳選し、ディティールにこだわって、高性能のコンフォートを提供するポルトローナ・フラウの住環境にその根本となる精神が現とれます。イタリアの家具作りの比類無き伝統を踏襲するポルトローナ・フラウは使用する素材の質の高さ、作りの丁寧さこそが製品のハイグレードな仕上がりを約束すると確信しております。ご自宅でポルトローナ・フラウのアームチェア、シェーズロング、ソファの掛け心地や肌触りの良さに慣れてしまうと、職場でレベルの低い“住環境”を受け入れるのは難しいものです。自然な流れとして、100年を超える歴史を経た今、ポルトローナ・フラウから“L'Ufficio”ザ・オフィスのコレクションが誕生しました。他のコレクションと同様に快適な掛け心地、細部の完成度の高さ、上質な素材をお約束し、厳選されたレザー、質の高いメタル類による高級仕上げ、高貴な大理石や石材を組合せる事により、高級感溢れるすっきりとしたラインを描きだします。仕上げや組合せの選択肢は非常に幅広く、カスタマイズの楽しみは限り無く広がります。ご自宅でポルトローナ・フラウの比類無い住環境に慣れた方に、オフィスでもその素晴らしい環境を再現していただけるのです。特に、Pelle Frau® ペルレ・フラウ® を使用した革張りは質の高さと耐久性をお約束し、エグゼクティブのオフィスに類を見ない風格を醸し出します。

## 办公家居之选

Poltrona Frau 高度多元化,不同的产品目录介绍了不同的功能,并共享相同的品牌理念。那就是,创造一个完美的空间,给使用者无论何时都能享受优雅和舒适。Poltrona Frau 的办公家具精髓得益于对家用家具炉火纯青的诠释,对舒适高雅的极致追求使其非常挑剔用料和细节。Poltrona Frau 坚信,真正的意大利处世哲学,卓越的表达不外乎其对材料和生产工艺的精益求精。任何已经习惯于 Poltrona Frau 家用家具无与伦比的舒适坐感和品质的人都会很难接受在工作中有不一致的办公体验。Poltrona Frau 是成功人士之选,在品牌 100 多年的发展历程中于 90 年代开发出办公系列家具。朝九晚五的办公室生活,由于 Poltrona Frau 的细致体贴使上班变得具有满足感;与起居生活一样同样完美的细节,是通过精心挑选的皮革,精致的木材,简约的结构,珍贵的大理石台面,以及一系列细节装饰来表达的,体现高级定制的无限可能。Poltrona Frau 将炉火纯青的 Pelle Frau® 皮革娴熟运用于高级经理人办公系列,将最高品质的皮革沿用至办公体验,给予职场精英无微不至的关怀。

# Rodolfo Dordoni

## Jobs



### RODOLFO DORDONI

Architetto e Designer, nasce e si laurea a Milano. Responsabile nel corso degli anni della direzione artistica di prestigiosi brand del design, disegna prodotti per numerose aziende. Dordoni Architetti, studio fondato a Milano da Rodolfo Dordoni, Luca Zaniboni e Alessandro Acerbi, opera nel campo dell'architettura e dell'interior design in ambito residenziale, commerciale ed allestitivo, sviluppando progetti di ville e abitazioni private, spazi industriali e commerciali curando la realizzazione di showrooms, stand espositivi, ristoranti, hotels.

### CONCEPT

Jobs esprime in sé e nel suo nome l'atto conclusivo di un percorso progettuale innovativo. Il nuovo sistema d'arredo direzionale nasce da un'attenta riflessione sull'evoluzione dei comportamenti in relazione alle nuove tecnologie e da un'accurata selezione dei materiali: pelle, legni lucidi ed opachi e strutture in metallo spazzolato arricchiscono in tono sobrio ed essenziale i differenti volumi e determinano nuove aree di lavoro.

### RODOLFO DORDONI

Architect and designer, Rodolfo Dordoni was born in Milan where He graduated. Responsible over the years for the art direction of numerous prestigious design brands, he has worked for many companies. Dordoni Architetti, a studio founded in Milan by Rodolfo Dordoni, Luca Zaniboni and Alessandro Acerbi, works in the field of architectural planning and interior design in the residential, commercial and exhibition areas, designing projects for private houses and villas, industrial and commercial spaces, and overseeing the realisation of showrooms, exhibition stands, restaurants, and hotels.

### CONCEPT

Jobs expresses in itself and its name the final act of an innovative design path. The new managerial system has been created through careful reflection on the evolution of behaviours in relationship to new technologies and through the careful selection of materials. Leather, polished and matte woods and brushed metal structures give a sober and essential feel to the different volumes and determine new work areas.

### ロドルフォ・ドルドーニ

建築家・デザイナー。ミラノ生まれ、同地で大学卒業。一流デザインブランドのアートディレクションの責任者として、多数の企業向けにデザインを手掛ける。Rodolfo Dordoni、Luca Zaniboni ルカ・ザニボーニ）、Alessandro Acerbi（アレッサンドロ・アチェルビ）がミラノに開いた建築事務所、Dordoni Architetti（ドルドーニ・アルキテッティ）は、住居、商業、展示に関連する建築・インテリアデザインの分野で活動。個人の邸宅や住宅、商業施設や産業施設のプロジェクトを実現する一方、ショールーム、展示会のスタンド、レストラン、ホテルなどの企画も手掛けている。

### コンセプト

Jobs はそれ自身、そしてその名前自体に、革新的で計画的な工程を踏むという明確な行為を表現しています。新たなエグゼクティブシステムは、新しいテクノロジーとの関係の中で起こる行動の変化についての慎重な考察と、注意深い素材の選択から生まれました。レザー、ポリッシュ加工とマット加工の木材、ブラッシュドメタル構造が、控えめに本質的なトーンの中にも多様なボリュームを生み出し新しい仕事の領域を切り開いています。

### 罗多尔夫·多尔多尼

建筑师及设计师，他出生于米兰，毕业于米兰理工大学建筑专业，多年来为很多知名设计品牌担任艺术指导。多尔多尼建筑事务所由罗多尔夫·多尔多尼、卢卡·扎尼波尼 Luca Zaniboni 和阿雷桑德罗·阿切尔比 Alessandro Acerbi 创建于米兰，主要从事住宅、商业及展览领域内的室内设计及建筑业务，同时负责私人住宅和别墅，工商业空间的项目设计，监督展厅，展馆，餐厅以及酒店等项目的实施完成。

### 理念

Jobs 系列以其命名表达了其在创新性设计领域之路的探索。通过仔细反思人类行为的进化关系和对材质的精挑细选，创造出了新的管理系统。通过对不同体积产品之上皮革，亮光饰面，哑光饰面以及拉丝金属结构的运用，创造出一个全新的理性却不可或缺的一种感觉。







↑ ↗ Jobs President Desk Large — Furniture Unit



Collezioni Ufficio — Jobs

Office Collections — Jobs

エグゼクティブシステムズ — Jobs

蟹 梅様 濂 鎌 仟 仞 — Jobs







↑ Jobs Executive Desk with meeting area — meeting area ↗ Open shelving



Collezioni Ufficio — Jobs

Office Collections — Jobs

エグゼクティブシステムズ — Jobs

蟹 梅様 漆 工 匠 — Jobs







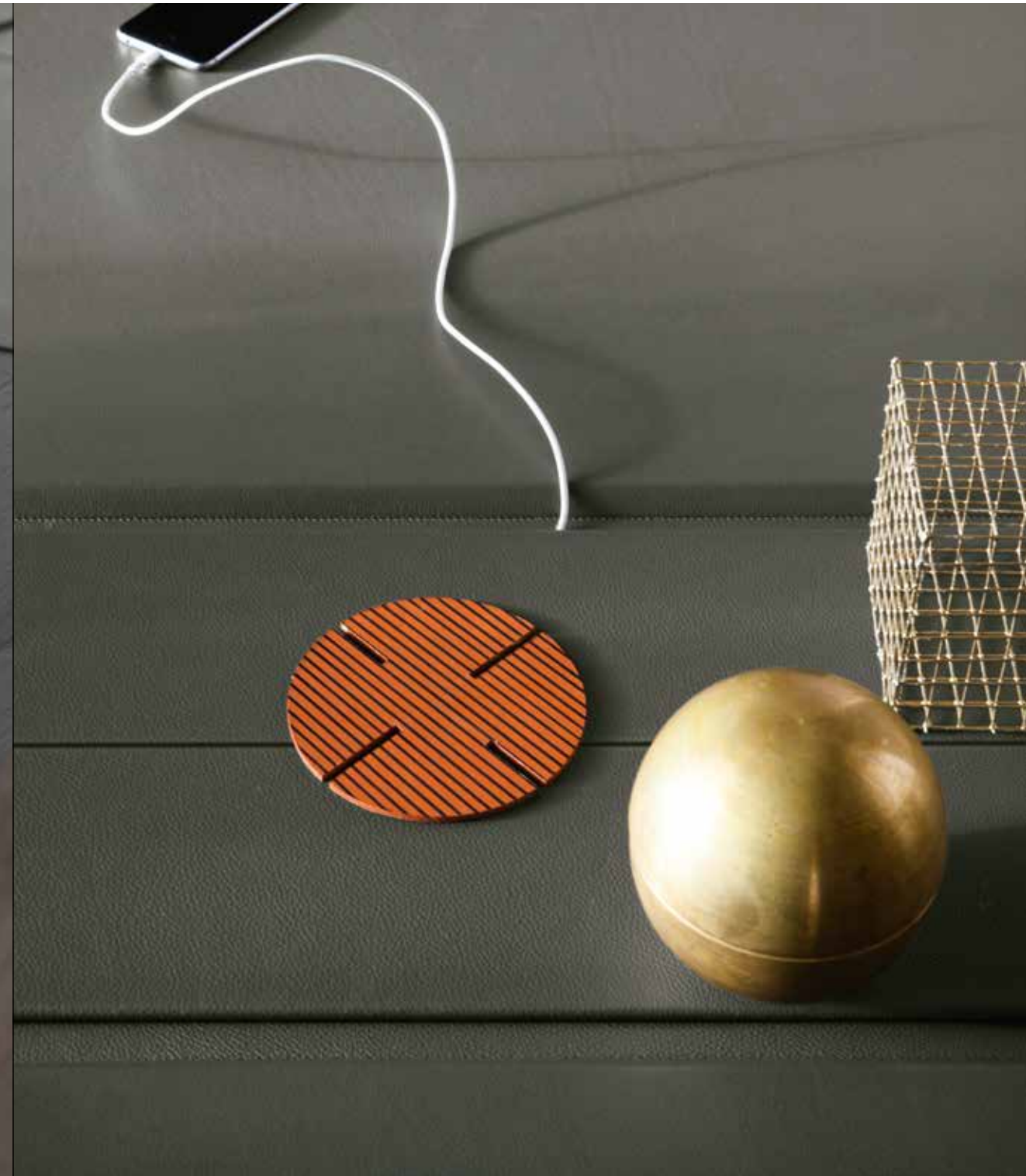

↑ Jobs Meeting Table 485×150 cm with President area — President area ↗ Hardware with central doors







↑ Jobs Bookcase 177×182 cm + Bookcase 177×182 cm — Shelves details ↗ Harmony of materials: leather, polished and matte surfaces

Collezioni Ufficio — Jobs

Office Collections — Jobs

エグゼクティブシステムズ — Jobs

蟹 樽様 漆 工 匠 — Jobs





# Jobs Materials

Armonia di materiali: pelle, rovere, acciaio.

Alternanza di superfici lucide e opache. Una combinazione di texture da applicare sui diversi elementi che compongono il sistema Jobs: strutture portanti, piani, basi, colonne passacavi, montanti, fessure per l'uscita dei cavi, mobili e cassettiere, "Guest area", "Meeting area" e "President area".

## ACCIAIO SATINATO VERNICIATO PIOMBO

Acciaio satinato verniciato piombo con caratteristica sezione a "T" per la struttura portante di tavoli e scrivanie e per i montanti delle librerie. Stessa finitura anche per la base dei cabinet.

## ROVERE PIOMBO E ROVERE TABACCO

Due differenti colori di rovere, nelle finiture lucido ed opaco. Opaco per la "Guest area" e la "Meeting area" delle Desk e i pannelli laterali della "President Area" dei tavoli, lucido per la colonna passacavi di tavoli e scrivanie e per i divisori delle Bookcase. In Rovere opaco, Piombo o Tabacco, è anche la fascia in legno che corre su tutta la lunghezza del piano delle Desk e dei tavoli che può consentire, grazie ad una fessura nascosta nel legno, l'uscita dei cavi elettrici. Mobili e cassettiere, impiattati in Rovere Piombo o Tabacco, abbinano finiture lucide e opache.

## PELLE FRAU® COLORSPHERE®

73 differenti nuance del ColorSphere®. 73 possibili colori di pelle con cui rivestire l'area di lavoro del piano di scrivanie e tavoli e i frontali dei cassetti di cassettiere e cabinet. Anche la "Guest area" delle Desk e la "President area" dei tavoli, a richiesta, possono essere rivestita in pelle come il resto del piano. Nelle librerie la pelle riveste gli schienali.

Harmony of materials: leather, Oakwood and steel. Alternating polished and matte surfaces. A combination of textures to apply to the different elements composing the Jobs system: supporting frames, tops, bases, cable management columns, cable outlet slots, cabinets and chests of drawers, Guest, Meeting and President area.

## BRUSHED STEEL WITH A LEAD PAINTED FINISH

Brushed steel with a lead painted finishing with "T" section characteristic for tables and desks' structures and bookcases' pillars. Same finishing for cabinets' bases too.

## LEAD OAKWOOD AND TOBACCO OAKWOOD

Two different colours of Oakwood, with polished and matte finishes. Matte for Guest and Meeting Area of the desks and lateral panels of the tables' President Area, and polished for the cable management columns of Tables and Desks and Bookcases' partitions. A matte-finish oak strip in Lead or Tobacco runs the entire length of the top of the Desks and Tables allowing the electric cables exit, thanks to a wood hiding crack. Cabinets and chests of drawers are oak veneered in Lead or Tobacco with glossy and matte finishes.

## PELLE FRAU® COLORSPHERE®

ColorSphere® offers 73 different shades. 73 possible leather colours for upholstering desks and tables' work Tops and drawers and cabinets' fronts. On request, the Desk's "Guest area" and the Table's "President Area" can be also upholstered in leather like the rest of the top. In the Bookcases the leather upholsters the backsides.

素材の調和:レザー、オーク、ポリッシュ加工とマット加工のスチールの組み合わせ Jobs システムを構成する複数の要素として採用されるテクスチャーのコンビネーション:耐力構造、天板、台、ケーブルモール、支柱、ケーブル用の溝、家具や引き出し、「ゲストエリア」、「ミーティングエリア」及び「プレジデントエリア」

## 鉛色のサテン仕上げスチール

鉛色のサテン仕上げスチールデスク及びテーブル、本棚、キャビネットの台の支柱の構造は、断面が特徴的な「T」構造。

## 鉛色オークと黄褐色オーク

オークには2色あり、ポリッシュ加工もしくはマット加工が施されています。マット加工はデスクの「ゲストエリア」と「ミーティングエリア」並びに、テーブルの「プレジデントエリア」のサイド・パネルに使われ、ポリッシュ加工はテーブルとデスクのケーブルモール及びブックケースの仕切りに使用。デスクやテーブルの作業台の長さにあわせた木製の平縁は、鉛色もしくは黄褐色のマット仕上げオークで、木材の内に隠してある溝を通して電気配線を取ることが可能です。家具とキャビネットは鉛色もしくは黄褐色のオークで化粧張りされ、ポリッシュ加工もしくはマット加工が施されます。

## PELLE FRAU® COLORSPHERE®

ColorSphere® のカラーシステムレザーの73の異なるニュアンス。デスクやテーブルの天板部の作業台や、チェストとキャビネットの引き出しの正面部分を覆うレザーの色に73の選択肢があります。デスクの「ゲストエリア」及びテーブルの「プレジデントエリア」、リクエストがあれば、卓上の他の部分と同じレザーにすることが可能。本棚は背板部がレザー張り。

和善的材料: 皮革、栎木、钢材。光滑与哑光表面交替。各种质地的组合应用于组成 Jobs 系统的不同元素之上: 承重结构、平面、底座、走线柱、框架、出线槽、家具及抽屉柜、“宾客区”、“会议区”和“总裁区”。

## 鉛色漆轧光钢材

鉛色漆轧光钢材, "T" 字截面独具特色, 用于桌子和写字台的支撑结构, 以及书架的框架。橱柜的底座采用同样的表面处理。

## 鉛色栎木和烟草色栎木

两种不同颜色的栎木, 有光亮和哑光两种表面效果。哑光的用于 Desk 的“宾客区”和“会议区”, 以及桌子的“总裁区”; 而光亮的则用于桌子和写字台的走线柱, 以及书柜的隔板。一个哑光栎木条, 铅色或烟草色, 贯穿了 Desk 和桌子台面的整个长度, 利用隐藏在木板中的细槽, 可用来将电线引出。家具和抽屉也采用的铅色或烟草色的栎木镶板, 并配有光亮和哑光的表面效果。

## PELLE FRAU® COLORSPHERE®

ColorSphere® 拥有 73 种色调。73 种颜色的皮革可用于装饰写字台和桌子台面的工作区, 以及抽屉和抽屉柜的面板。根据需要, Desk 的“宾客区”和桌子的“总裁区”也可如台面的其余部分以皮革装饰。在书架上, 皮革可用于装饰后部衬板。



## Jobs President Desk

Piano e "Guest area" in Pelle Frau® SC 28 Seppia. Mobile in Rovere Piombo.

Top and "Guest area" in Pelle Frau® leather SC 28 Seppia. Lead Oak Cabinet.

Pelle Frau® SC 28 Seppia (ベッレフラウ® SC 28 セビア)の作業台と"Guest area" (ゲストエリア)。Piombo (鉛色)のオーク製家具。

桌子台面和会客区块采用 Pelle Frau® SC 28 Seppia 皮革,柜体采用铅色橡木饰面。

Piano in Pelle Frau® SC 28 Seppia. "Guest area" e mobile in Rovere Piombo.

Top in Pelle Frau® leather SC 28 Seppia. "Guest area" and cabinet in Lead Oakwood.

Pelle Frau® SC 28 Seppia (ベッレフラウ® SC 28 セビア)の作業台。Piombo のオーク製 "Guest area" と引き出しの筐体。

桌子台面采用 Pelle Frau® SC 28 Seppia 皮革,会客区块和柜体采用橡木。

Il mobile può essere montato a destra o a sinistra della scrivania rispetto alla posizione del fruitore determinandone il verso.

The cabinet can be assembled on the right or left of the desk, according to the user's preference

引き出しの筐体は、利用者の位置から見てデスクの左右どちらかに方向を決めて設置します

柜体可以根据客户需求组装在左侧和右侧。



## Jobs President Desk Large

Piano e "Guest area" in Pelle Frau® SC 28 Seppia. Mobile in Rovere Piombo.

Top and "Guest area" in Pelle Frau® leather SC 28 Seppia. Lead Oakwood Cabinet.

Pelle Frau® SC 28 Seppia (ベッレフラウ® SC 28 セビア)の作業台と"Guest area" (ゲストエリア)。Piombo (鉛色)のオーク製引き出しの筐体。

桌子台面和会客区块采用 Pelle Frau® SC 28 Seppia 皮革,柜体采用铅色橡木饰面。

Piano in Pelle Frau® SC 28 Seppia. "Guest area" e mobile in Rovere Piombo.

Top in Pelle Frau® leather SC 28 Seppia. "Guest area" and cabinet in Lead Oakwood.

Pelle Frau® SC 28 Seppia (ベッレフラウ® SC 28 セビア)の作業台。Piombo のオーク製 "Guest area" と引き出しの筐体。

桌子台面采用 Pelle Frau® SC 28 Seppia 皮革,会客区块和柜体采用橡木。

Il mobile può essere montato a destra o a sinistra della scrivania rispetto alla posizione del fruitore determinandone il verso.

The cabinet can be assembled on the right or left of the desk, according to the user's preference.

引き出しの筐体は、利用者の位置から見てデスクの左右どちらかに方向を決めて設置します。

柜体可以根据客户需求组装在左侧和右侧。





La serie di scrivanie si amplia, con President e Executive Desk nella nuova versione da 183 cm di lunghezza. Maggiormente compatte nelle dimensioni, per uno spazio di lavoro agile e contemporaneo. Curate in ogni dettaglio e funzionali. Per Presidente Desk cassetiera completa di vano a giorno e due cassetti. Per Executive Desk un mobile con due cassetti e classificatore. I frontali dei cassetti, dotati di rientro ammortizzato come il classificatore, sono rivestiti in Pelle Frau® del ColorSphere®.

There are new editions for the desk series, with President and Executive Desk in the new 183 cm long version. They are even more compact in size, for a versatile, contemporary workspace. Attention is paid to every detail and practical. President Desk has an open compartment and two drawers. Executive Desk has two drawers and filing cabinet. The fronts of the drawers, fitted with a soft-close mechanism like the filing cabinet, are covered in Pelle Frau® leather from the ColorSphere®.

デスクシリーズにも全長 183cm の President デスクと Executive デスクが加わりました。使いやすく現代的な作業スペースを提案するよりコンパクトなサイズです。機能的でディテールへのこだわりが光ります。Presidente Desk用のオープンコンパートメントと2つの引き出し。Executive Desk用の2つの引き出しとファイリングキャビネット(書類整理庫)。ファイリングキャビネット(書類整理庫)のようにソフトクローズ機能が搭載された引き出しのフロントは ColorSphere® の Pelle Frau® でコーティングされています。

写字台系列也增添新成员，President 和 Executive Desk 款式增加长 183 米的版本。尺寸非常紧凑，适合灵动现代的工作空间。注重细节，功能齐全。Presidente Desk 的抽屉柜配备一个外露隔槽和两个抽屉。Executive Desk 小柜配备两个抽屉和一个文件分类区。抽屉和文件分类区均配备缓冲归位装置，面板覆盖 Pelle Frau® ColorSphere® 软皮。

## Jobs President Desk 72"

Piano e "Guest area" in Pelle Frau® SC 26 Topo. Mobile in Rovere Piombo.

Top and "Guest area" in Pelle Frau® leather SC 26 Topo. Lead Oakwood Cabinet.

Pelle Frau® SC 26 Topo (ベッレフラウ® SC 26 グレーマウス)の作業台と "Guest area" (ゲストエリア)。Piombo (鉛色)のオーク製引き出しの筐体。

桌子台面和会客区块采用 Pelle Frau® SC 26 Topo 皮革。柜体采用铅色橡木饰面。

Il mobile può essere montato a destra o a sinistra della scrivania rispetto alla posizione del fruitore determinandone il verso.

The cabinet can be assembled on the right or left of the desk, according to the user's preference.

引き出しの筐体は、利用者の位置から見てデスクの左右どちらかに方向を決めて設置します。

柜体可以根据客户需求组装在左侧和右侧。



## Jobs Executive Desk 72" / Executive Desk

Piano e "Guest area" in Pelle Frau® SC 80 Bruno Havana.

Top and "Guest area" in Pelle Frau® leather SC 80 Bruno Havana.

Pelle Frau® SC 80 Bruno Havana (ペツレ Frau® SC 80 / ハバナブラウン)の作業台と "Guest area" (ゲストエリア)。

桌子台面和会客区块采用 Pelle Frau® SC 80 Bruno Havana 皮革,柜体采用铅色橡木饰面。



Piano in Pelle Frau® SC 80 Bruno Havana. "Guest area" in Rovere Tabacco.

Top in Pelle Frau® leather SC 80 Bruno Havana. "Guest area" in Tobacco Oak.

Pelle Frau® SC 80 Bruno Havana (ペツレ Frau® SC 80 / ハバナブラウン)の作業台。"Guest area" は Tabacco (黄褐色)のオーク。

桌子台面采用 Pelle Frau® SC 80 Bruno Havana 皮革,会客区块和柜体采用橡木。



La colonna passacavi è in Rovere Tabacco lucido e può essere montata a destra o a sinistra della scrivania rispetto alla posizione del fruitore.

The cable management column is in polished Tobacco Oakwood and can be assembled on the right or left of the desk in relation to the position of the user.

ケーブルモールはポリッシュ加工を施した Tabacco のオークで、利用者から見てデスクの左右どちらにでも設置できます。

柜体可以根据客户需求组装在左侧和右侧。



## Jobs Executive Desk Large

Piano e "Guest area" in Pelle Frau® SC 80 Bruno Havana.

Top and "Guest area" in Pelle Frau® leather SC 80 Bruno Havana.

Pelle Frau® SC 80 Bruno Havana (ペツレ Frau® SC 80 / ハバナブラウン)の作業台と "Guest area" (ゲストエリア)。

桌子台面和会客区块采用 Pelle Frau® SC 80 Bruno Havana 皮革,柜体采用铅色橡木饰面。



Piano in Pelle Frau® SC 80 Bruno Havana. "Guest area" in Rovere Tabacco.

Top in Pelle Frau® leather SC 80 Bruno Havana. "Guest area" in Tobacco Oakwood.

Pelle Frau® SC 80 Bruno Havana (ペツレ Frau® SC 80 / ハバナブラウン)の作業台。"Guest area" は Tabacco (黄褐色)のオーク。

桌子台面采用 Pelle Frau® SC 80 Bruno Havana 皮革,会客区块和柜体采用橡木。



La cassettera è sempre posizionata sul lato opposto alla colonna passacavi.

The chest of drawers is always positioned on the opposite side to the cable management column.

引き出しは常にケーブルモールの反対側に設置。

柜体可以根据客户需求组装在左侧和右侧。





## Jobs Executive Desk with Meeting Area

Piano e "Guest area" in Pelle Frau® SC 80 Bruno Havana. "Meeting area" in Rovere Tabacco.

Top and "Guest area" in Pelle Frau® leather SC 80 Bruno Havana. "Meeting area" in Tobacco Oakwood.

Pelle Frau® SC 80 Bruno Havana (ペッレフラウ® SC 80 ハバナブラウン) の作業台と "Guest area" ゲストエリア。"Meeting area" (ミーティングエリア) は、Tabacco (黄褐色) のオーク。

桌子台面和会客区块采用 Pelle Frau® SC 80 Bruno Havana 皮革，会议区块采用烟草色橡木饰面。



## Jobs Easy Desk with Meeting Area

La "Meeting area" può essere installata esclusivamente sul lato dove è presente la colonna passacavi.

The "Meeting area" can only be installed on the side of the cable management column.

"Meeting area" (ミーティングエリア) はケーブルモール側のみ設置可能。

会议区块只可以安装在电缆管理管道侧面。

La colonna passacavi è in Rovere Tabacco lucido.

The cable management column is in polished Tobacco Oakwood.

ケーブルモールは、ポリッシュ加工を施した Tabacco (黄褐色) のオーク製。

电缆管理管道采用亮光烟草色橡木饰面。



## Jobs Easy Desk

Piano e "Guest area" in Pelle Frau® SC 80 Bruno Havana.

Top and "Guest area" in Pelle Frau® leather SC 80 Bruno Havana.

Pelle Frau® SC 80 Bruno Havana (ペッレフラウ® SC 80 ハバナブラウン)の作業台と"Guest area" (ゲストエリア)。

桌子台面和会客区块采用 Pelle Frau® SC 80 Bruno Havana 皮革。



Piano in Pelle Frau® SC 80 Bruno Havana. "Guest area" in Rovere Tabacco.

Top in Pelle Frau® leather SC 80 Bruno Havana. "Guest area" in Tobacco Oakwood.

Pelle Frau® SC 80 Bruno Havana (ペッレフラウ® SC 80 ハバナブラウン)の作業台。"Guest area" は、Tabacco (黄褐色)のオーク製。

桌子台面采用 Pelle Frau® SC 80 Bruno Havana 皮革，会客区块采用烟草色橡木饰面。



Colonna passacavi in Rovere Tabacco lucido.

The cable management column is in polished Tobacco Oakwood.

ケーブルモールは、ポリッシュ加工を施した Tabacco のオーク製。

电缆管理管道采用亮光烟草色橡木饰面。



## Jobs Easy Desk Large

Piano e "Guest area" in Pelle Frau® SC 80 Bruno Havana.

Top and "Guest area" in Pelle Frau® leather SC 80 Bruno Havana.

Pelle Frau® SC 80 Bruno Havana (ペッレフラウ® SC 80 ハバナブラウン)の作業台と"Guest area" (ゲストエリア)。

桌子台面和会客区块采用 Pelle Frau® SC 80 Bruno Havana 皮革。



Piano in Pelle Frau® SC 80 Bruno Havana. "Guest area" in Rovere Tabacco.

Top in Pelle Frau® leather SC 80 Bruno Havana. "Guest area" in Tobacco Oakwood.

Pelle Frau® SC 80 Bruno Havana (ペッレフラウ® SC 80 ハバナブラウン)の作業台。"Guest area" は、Tabacco (黄褐色)のオーク製。

桌子台面采用 Pelle Frau® SC 80 Bruno Havana 皮革，会客区块采用烟草色橡木饰面。



La colonna passacavi può essere montata a destra o a sinistra della scrivania rispetto alla posizione del fruitore.

The cable management column can be assembled on the right or left of the desk in relation to the position of the user.

ケーブルモールは利用者から見てデスクの左右どちらにでも設置できます。

电缆管理管道可以根据用户需求安装在左边或者右边。





Vano interno al piano di lavoro corredato di vassoio portapenne e equipaggiato centralmente con un dispositivo di elettrificazione da acquistare separatamente.

Inner compartment of the work surface complete with pen tray and equipped with a central electrification device can be purchased separately.

作業台内部の空間には、ペン置き用のトレーが備えられ、中心には別途販売されている電化装置を装備できます。

工作区块的内部隔断可以放置钢笔托盘，安装充电插口，需要单独采购。

Jobs President Desk — Dettaglio tecnico del passaggio cavi — Technical details of the cable management — ケーブル配線に関する技術的詳細 — 电缆管道的技术细节

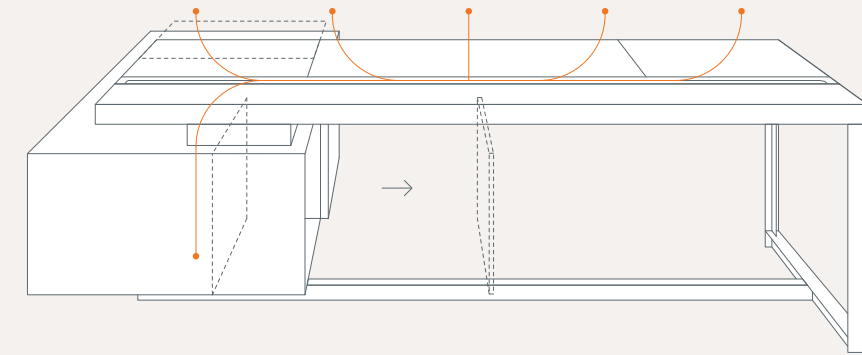

Jobs Executive Desk — Dettaglio tecnico del passaggio cavi — Technical details of the cable management — ケーブル配線に関する技術的詳細 — 电缆管道的技术细节

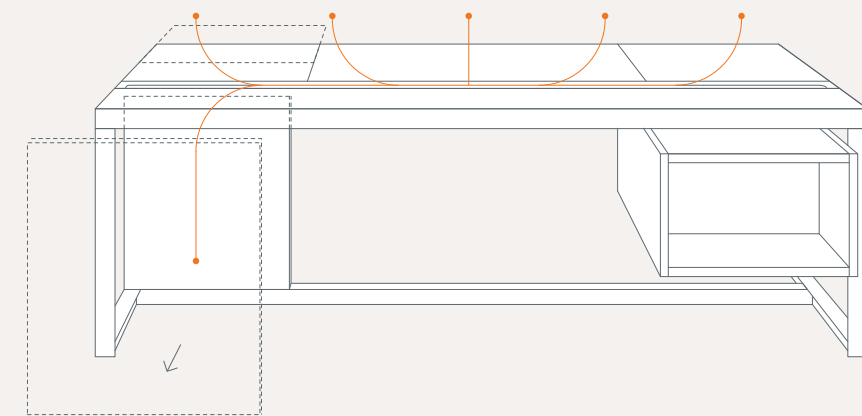



## Jobs Modular Meeting Table

Jobs Meeting Table è composto di tre elementi: struttura portante in acciaio satinato verniciato piombo con sezione a "T", piano in Pelle Frau® del ColorSphere® e una colonna che cela il passaggio dei cavi elettrici in Rovere con finitura lucida. Il piano in pelle è disponibile con l'area centrale in Rovere, Piombo o Tabacco, con finitura opaca o in Pelle Frau® del ColorSphere®.

The Jobs Meeting Table is made up of three elements: a supporting frame in brushed lead-coloured steel with T cross-section, a large top surface in Pelle Frau® leather, and an Oak wooden column with polished finish, which conceals electric cables. The leather top is available with the central part either in Lead Oak or Tobacco Oak veneer with matt finish or covered in Pelle Frau® ColorSphere® leather.

Jobs Meeting Table は、3つのエレメントで構成されています。これらのエレメントは、「T」字型セクション付き、リードカラー塗装およびサテン加工されたスチール製の支持構造、Pelle Frau® ベッレ・フラウ® レザー使用の天板、および光沢のあるオーク材使用のケーブル通しが内部にある支柱です。レザー製の天板は、オークかマット加工されたリードカラーおよびタバコカラー、または Pelle Frau® ColorSphere® ベッレ® フラウ® カラーシステムのバージョンがあります。

Jobs会议桌由三个部分组成：支撑结构采用“T”字截面铅色漆面轧光钢材，台面采用 ColorSphere® 的 Pelle Frau® 皮革，一根光亮表面的栎木立柱将电线隐藏其中。皮革台面的中心区域可选配栎木镶板，铅色或烟草色，哑光表面效果，或使用 ColorSphere® 的 Pelle Frau® 皮革包裹。



I tavoli da riunione modulari sono disponibili in sette diverse dimensioni che spaziano da 266 cm a 704 cm, tutte attrezzabili a richiesta con President area nelle varianti legno o pelle.

The modular meeting tables are available in seven different sizes ranging from 266 cm to 704 cm. All the versions can be equipped with President area in Oakwood or leather.

モジュラー式の会議用テーブルは、最も小さい 266cm から最大 704cm までの7つの大きさから選ぶことができ、必要に応じて木材、またはレザー使用のプレジデント・エリアを追加することが可能です。

模块化会议桌，从 266cm 到 704cm 共有7种不同尺寸可供选择，所有规格均可根据要求配备木材或皮革的总裁区。

Nelle foto il rivestimento è in Pelle Frau® SC 80 Bruno Havana rispettivamente nelle versioni senza President area e con President area, nelle varianti in Rovere tabacco o Pelle Frau® SC 56 Siena.

In the photos the upholstery is in Pelle Frau® leather SC 80 Bruno Havana in the versions without President area and with President area in Tobacco Oakwood or in Pelle Frau® SC 56 Siena.

写真には Pelle Frau® SC 80 Bruno havana ベッレ・フラウ® SC 80 ブレーノ・ハバナ、リードカラーのオークバージョンが載っています。最後の写真のタイプには Pelle Frau® SC 56 Siena ベッレ・フラウ® SC 56 シエーナが使用されています。

照片中的款式采用 Pelle Frau® SC 80 Bruno havana 雪茄色皮革包裹，可配有烟草色栎木或 Pelle Frau® 56 Siena 皮革的总裁区，如最后一张照片所示。

## Jobs Modular Meeting Table





La "president area" è prevista, a scelta, in uno dei due lati corti dei Meeting Table. Per questa variante il pannello centrale è rivestito in Pelle Frau® del ColorSphere® mentre i due pannelli laterali sono disponibili sia in Rovere con finitura opaca sia rivestiti in Pelle Frau® del ColorSphere®. Lo spessore del piano, alle due estremità del tavolo, è rifinito con una cornice incassata in fibra di legno a media densità impiallacciata Rovere Piombo o Rovere Tabacco con finitura opaca.

The Meeting Tables can include a "president area" at one end. In this case, the central panel is covered in Pelle Frau® ColorSphere® leather, while the two side panels are available either in Lead Oak or Tobacco Oak veneer MDF with matt finish or covered in Pelle Frau® ColorSphere® leather. The two short ends of the table top have recessed edging in Lead Oak or Tobacco Oak veneer MDF with matt finish.

「プレジデント・エリア」は、お好みにより Meeting Table の両サイドのいずれかの部分に追加できます。このバージョンのセンターパネルは、ColorSphere® の Pelle Frau® でカバーされ、その反面サイドパネルは、マット加工のオーク材または ColorSphere® の Pelle Frau® 使用の 2 つのバージョンからえらべます。テーブルの両サイドのパネルの厚み部分の仕上げは、リードカラーのオーク材で化粧張りされた中密度ウッドファイバー、またはマット加工のタバコカラーのオーク材です。

可选择将会议桌的一个短边设置为“总裁区”。对于此款，中部镶板采用 ColorSphere® 的 Pelle Frau® 皮革进行包覆，而两个侧板即可配上哑光效果的栎木，也可选用 ColorSphere® 的 Pelle Frau® 皮革包覆。桌子台面的两端的厚度方向，采用嵌入到中密度纤维板中铅色或烟草色哑光表面栎木饰板封边。



# Jobs

## Modular Meeting Table

Con pannelli centrali

With central panels

センター・パネルから

中央面板

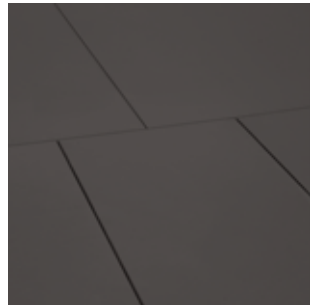

Con pannelli centrali e borchie passacavi

With central panels and cable tidy grommets

センター・パネルと配線用メタル・パーツを通して

带电线收纳管的中央面板



Con sportelli centrali

With central doors

センターの開口部から

可开合中央面板



Sono disponibili 3 versioni Hardware diversamente attrezzabili per il passaggio dei cavi elettrici.

They are available in 3 Hardware versions that can be furnished in different ways to accommodate electrical cables.

ケーブル通しとして異なるコンポーネントで構成できる3つのハードウェアを取り扱っています。

3种五金件版本·用于不同的走线方式设置。



Jobs Meeting Table

Dettaglio tecnico del passaggio cavi - Technical details of the cable management - Détail technique pour le passage des câbles - Technische Zeichnung der Kabelführung

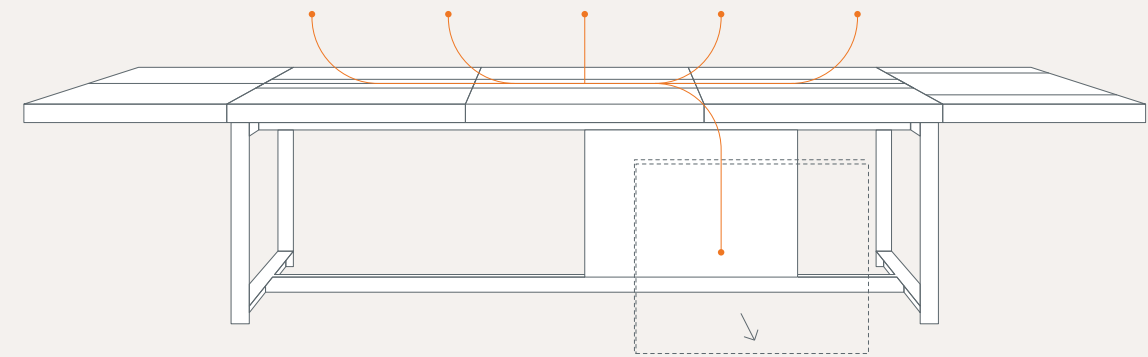





La versione Hardware con pannelli centrali è dotata di un tunnel passacavi di lamiera di metallo traforata e verniciata di colore nero. La versione Hardware con pannelli centrali e passacavi presenta una serie di borchie passacavi in metallo inserite al centro di ciascun pannello centrale e disponibili nella versione verniciata nera. La versione Hardware con sportelli è attrezzata con sportelli che danno accesso ad un vano interno dotato di una borchia passacavi in metallo cromata o verniciata nera.

The Hardware with central panels version is equipped with a cable tidy tunnel in perforated sheet metal and painted black. The Hardware with central panels and cable tidies version has a series of metal cable tidy grommets inserted in the centre of each central panel and available in the version painted black. The Hardware with doors version is equipped with doors that can be used to access an internal compartment equipped with a cable tidy grommet in chrome-plated metal or painted black.

センターパネル付きハードウェア・バージョンは、ブラックカラー塗装加工されたパンチ加工が施された鉄版製のケーブル通しが付いています。センターパネルとケーブル通し付きのハードウェア・バージョンは、各センターパネルの中心部分に、ケーブル通し用のブラックカラー塗装のメタル製飾り鉋が取り付けられています。ドアつきハードウェア・バージョンに関しては、ドアから内部にアクセスし、ケーブル通し用のクローム加工、またはブラックカラー塗装のメタル製飾り鉋があります。

带有中心镶板的五金件版本，配有金属板制成的走线槽，上有打孔，黑色漆面。带有中心镶板和穿线环的五金件版本，配有一系列的金属穿线环，分布于每块中心镶板的中部，黑色漆面。带有中心盖门的五金件版本，设有盖门，内部配有镀铬或黑漆金属穿线环。

## Jobs Bookcase 177×182 cm

Jobs Bookcase è una libreria "Freestanding", bifacciale a configurazione fissa disponibile anche nella variante "Wall" per essere avvicinata alla parete. Nelle foto le librerie sono proposte nella variante Pelle Frau® SC 28 Seppia abbinata al Rovere Piombo, nelle finiture lucida e opaca.

The Jobs Bookcase is a Freestanding, double-sided bookcase with fixed configuration, also available in the "Wall" version to be closer to the wall. In the images libraries are proposed in Pelle Frau® leather SC 28 Seppia combined with Lead Oak, in polished and matte finishes.

Jobs Bookcase は、フリースタンド式の本箱です。固定式であり、両サイドから利用できます。「Wall」バージョンは、壁に近づけることができます。写真は、Pelle Frau® SC 28 Seppia ベッレ・フラウ® SC 28 セビアとリードカラーのオーク(グロス、およびマットタイプ)がペアになっているバージョンです。

Jobs书架是一款独立式书架，双面开放，配有固定装置；也可提供“Wall”款，可贴墙安放。照片中的书架采用了Pelle Frau® SC 28 Seppia 皮革与铅色栎木组合装饰，光亮和哑光表面效果。



## Jobs Bookcase 234×145 cm

Elementi divisorii a "T", composti da un pannello verticale in legno laccato lucido e pannello di fondo in Pelle Frau® del ColorSphere®, sono disposti sulle mensole con schema irregolare. Montanti a "T" in acciaio satinato verniciato piombo, elementi identificativi della collezione, sono fissati alle estremità della libreria.

"T"-shaped dividing elements made up of a vertical panel in gloss lacquer wood and lower panel in Pelle Frau® leather from the ColorSphere® are arranged in an irregular fashion on the shelves. The "T" cross-sections with lead-coloured brushed steel uprights, distinctive features of the collection, are attached to the ends of the bookcase.

「T」字型のディバイダー・エレメントは、グロスラッカー加工が施された垂直パネルと ColorSphere® の Pelle Frau® leather ベッレ・フラウ®レザー使用のバックパネルで構成されています。ディバイダーは、変則的に棚に設置されます。このコレクションの特徴であるリードカラーのスチール製「T」字型支柱は、本箱の先端部分に取り付けられています。

「T」字型隔断由垂直的漆面木饰板和 ColorSphere® 的 Pelle Frau® 皮革衬板组成，在隔架上不规则分布。该系列的标志性元素「T」字型支撑结构采用铅色漆面轧光钢材，固定在书架的各端。







Gli elementi verticali dei divisori sono in legno multistrato di betulla impiallacciato Rovere Piombo o Rovere Tabacco con finitura lucida disposti perpendicolarmente alla lunghezza dei ripiani e pannelli con rivestimento in Pelle Frau® del ColorSphere® disposti parallelamente alla lunghezza dei ripiani. Le mensole con spessore importante sono in Rovere Piombo o Tabacco opaco.

The vertical elements of the dividers are in Rovere Piombo or Rovere Tabacco veneered birch plywood with glossy finish and are perpendicular to the lengths of the shelves and panels upholstered in Pelle Frau® leather from the ColorSphere® arranged in parallel to the length of the shelves. Jobs Bokcase has thick shelves in mat Rovere Piombo or Tabacco.

デバイダーの垂直パネルは、グロス加工が施されたリードカラー、またはタバコカラーのオーク材で化粧張りされたカバの木の積層板を使用しています。このタイプのデバイダーは、棚の長さに対し垂直に設置されています。その反面、ColorSphere® の Pelle Frau® leather ベッレ・フラウ®レザー使用のパネルは、棚の長さに対し、平行に設置されています。厚みのある棚は、リードカラー、またはタバコカラーのオーク材を使用。

垂直隔板采用桦木胶合板，配以光亮表面的铅色或烟草色栎木饰板，沿层板的整个长度垂直排列；与层板的长度方向平行的，配以 ColorSphere® 的 Pelle Frau® 皮革包覆面板。而较厚的架板则为哑光效果的铅色或烟草色栎木饰板。





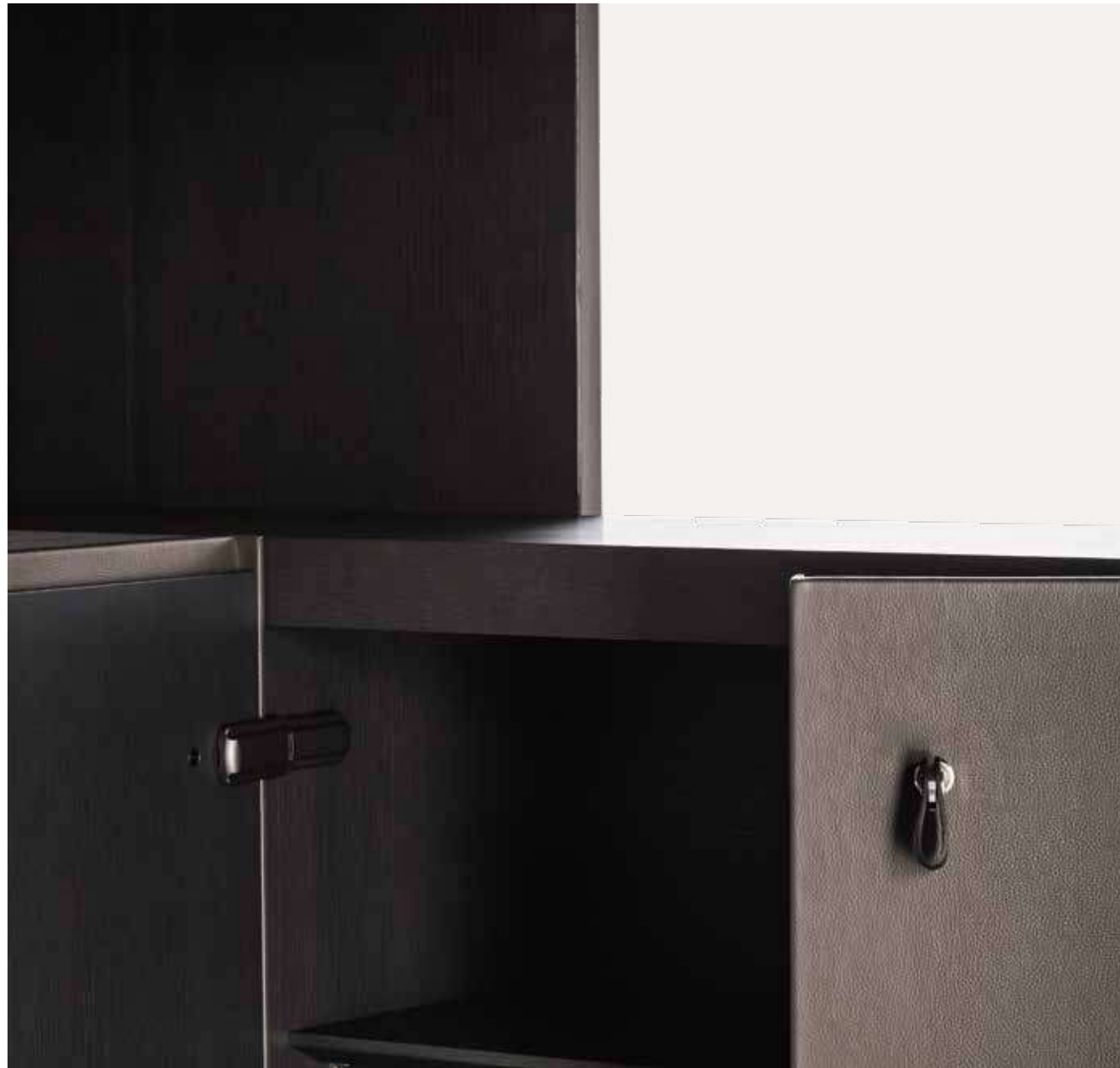

## Jobs High Cabinet

Top in Rovere Piombo opaco.

Lead Oakwood top with matte finish.

上部はマット加工を施した Piombo (鉛色) のオーク製。

卓子台面採用哑光铅色橡木饰面。

Il rivestimento frontale dei cassetti e dell'anta è in Pelle Frau® SC 28 Seppia.

Drawer fronts upholstered in Pelle Frau® leather SC 28 Seppia.

引き出しと扉の上張りは Pelle Frau® SC 28 Seppia (ペッレフラウ® SC 28 セピア) 製。

抽屉面板采用 Pelle Frau® SC 28 Seppia 皮革软包。



Jobs High Cabinet è sofisticato nelle finiture e nei materiali come l'intera collezione. Acciaio tinto piombo per i montanti verticali, con la caratteristica sezione a T che torna in tutti gli elementi Jobs. Pelle Frau® del ColorSphere® per il rivestimento degli sportelli in MDF. Stesso materiale per tutti gli altri elementi, mensole, vani e pannello posteriore: l'impiallacciatura in rovere tinto piombo o tinto tabacco alterna con eleganza superfici lucide e opache.

Jobs High Cabinet has the same sophisticated finishes and materials as the rest of the collection. Lead-painted steel for the vertical uprights, with the characteristic T-section featured by all Jobs elements. Pelle Frau® leather from the ColorSphere® covers the MDF cupboard doors. All the other elements, shelves, open units and rear panel are in the same material—lead- or tobacco-stained oak veneer, which elegantly alternates with glossy and matt surfaces.

Jobs High Cabinet は他のコレクション同様、洗練された素材と仕上げが特徴となっています。垂直部材には Jobs の全てエレメントの特徴であるT字断面の鉛染色仕上げのスチールが使用されています。MDF 製扉はColorSphere® の Pelle Frau® でコーティングされています。その他全てのエレメント(棚、コンパートメント、後部パネル)は同じ素材:光沢仕上げとマット仕上げの表面がエレガントに交差する鉛染色またはタバコ染色のオーク材化粧張りです。

Jobs High Cabinet (高柜) 和整个产品系列相同，配备复杂的表面修饰和材料。铅色钢制垂直支柱，采用特色T型横截面，是 Jobs 各款家具的特色所在。中密度纤维板 (MDF) 小门板覆盖 Pelle Frau® ColorSphere® 软皮。所有其他元素、架板、隔槽和背板也是用相同的材料：铅色或烟草色无梗花橡木贴面与典雅的抛光和哑光表面交替。

## Jobs Low Cabinet L284 / L230

Top in Rovere Piombo lucido.

Lead Oakwood top with polished finish.

上部はポリッシュ加工を施した Piombo (鉛色) のオーク製。

桌子台面采用亮光铅色橡木饰面。



Il rivestimento frontale dei cassetti e dell'anta è in Pelle Frau® SC 28 Seppia.

Drawer fronts upholstered in Pelle Frau® leather SC 28 Seppia.

引き出しと扉の上張りは Pelle Frau® SC 28 Seppia (ベッレフラウ® SC 28 セビア) 製。

抽屉面板采用 Pelle Frau® SC 28 Seppia 皮革软包。



## Jobs Drawer Unit

Top in Rovere Piombo opaco.

Lead Oakwood top with matte finish.

上部はマット加工を施した Piombo (鉛色) のオーク製。

桌子台面采用哑光铅色橡木饰面。



Frontali in Pelle Frau® SC 28 Seppia.

Fronts in Pelle Frau® leather SC 28 Seppia.

正面は Pelle Frau® SC 28 Seppia (ベッレフラウ® SC 28 セビア) 製。

前面采用 Pelle Frau® SC 28 Seppia 皮革软包。



La base è verniciata nero testurizzato antigraffio e dotata di 4 ruote piroettanti

The base is painted black with a texturized scratch-resistant finish and has four castors.

台はアンチスクラッチ加工とテクスチャー加工を施したブラックカラーで、4つのキャスター付き。

底座采用黑色纹理防划饰面，带四个脚轮。



Il retro del mobile è dotato di uno sportello ribaltabile che consente l'accesso ad un piccolo vano interno utile alla fuoriuscita dei cavi che, dal pavimento, salgono fino al top attraverso la fessura presente lungo tutta la lunghezza del piano.

The back of the Cabinet is equipped with a folding door that offers access to a small interior compartment. This compartment allows cables, which come up from the floor and reach the top of the desk, to come out through the slot that runs along the entire length of the top.

床からの配線がボード沿いの溝を通してトップまで達するための通り道となる小さな穴を抜けるよう、蓋付の入り口が家具の後ろ側に付いています。

柜子的背后有一面小门通向内部小室，电线等可以从地面穿过小室通到桌面。

Jobs Low Cabinet L284 — Dettaglio tecnico del passaggio cavi — Technical details of the cable management — ケーブル配線に関する技術的詳細 — 电缆管道的技术细节

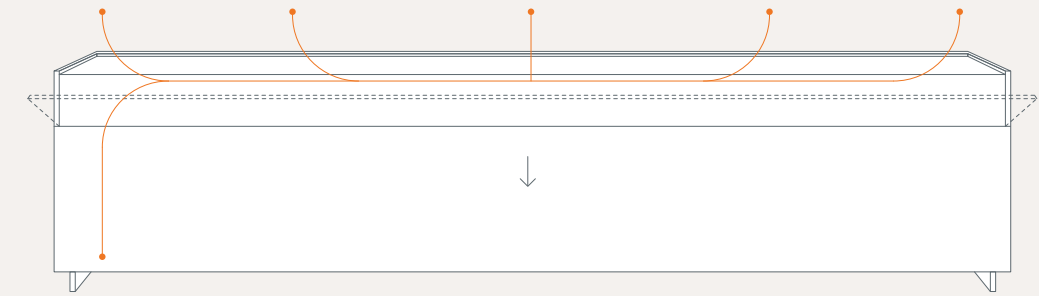



**Jobs President Desk 72"** — "Guest area" in Pelle Frau® SC leather  
5580698

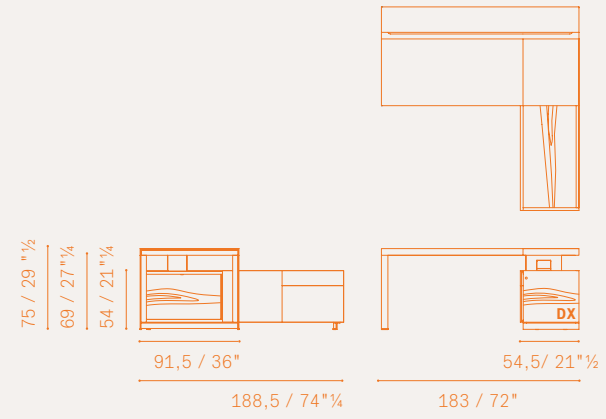

**Jobs President Desk 72"** — "Guest area" in Oakwood  
5580698

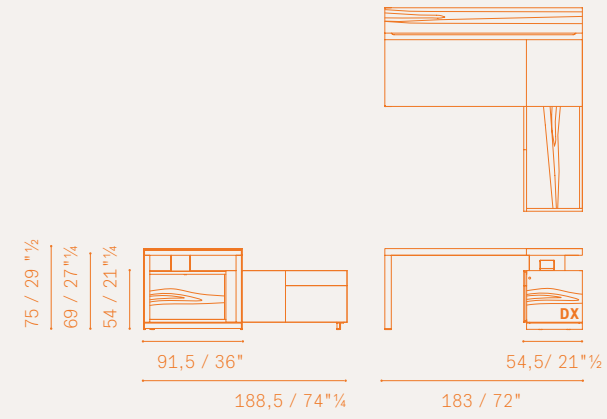

**Please note:**  
this catalogue shows only some technical drawings, in order  
to know all the availabilities please refer to the current price list.

**Jobs Executive Desk 72"** — "Guest area" in Pelle Frau® SC leather  
5580697

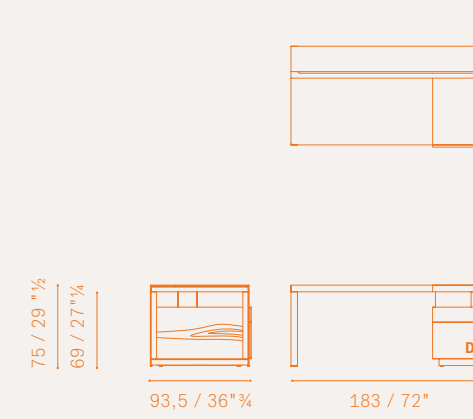

**Jobs Executive Desk 72"** — "Guest area" in Oakwood  
5580697

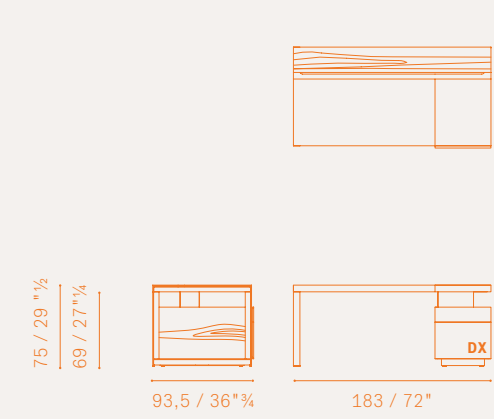

**Jobs President Desk** — "Guest area" in Pelle Frau® SC leather  
5580706

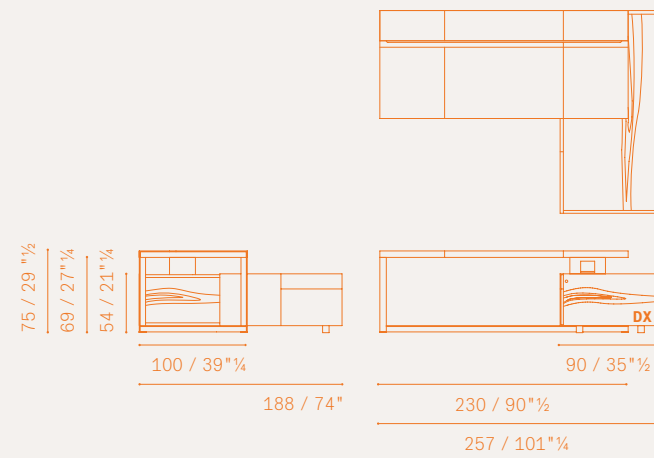

**Jobs President Desk** — "Guest area" in Oakwood  
5580706

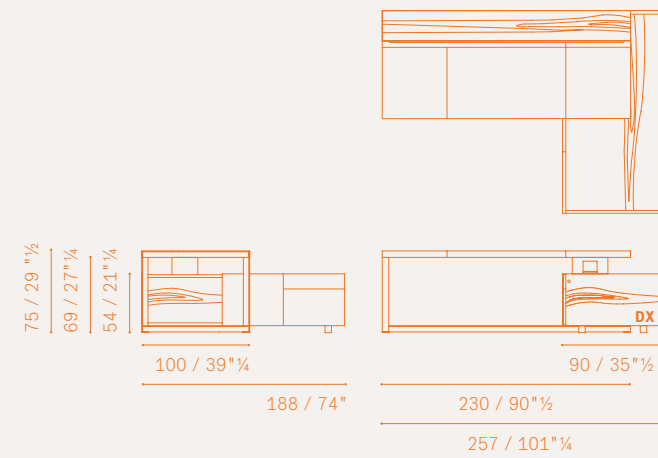

**Jobs Executive Desk** — "Guest area" in Pelle Frau® SC leather  
5580705

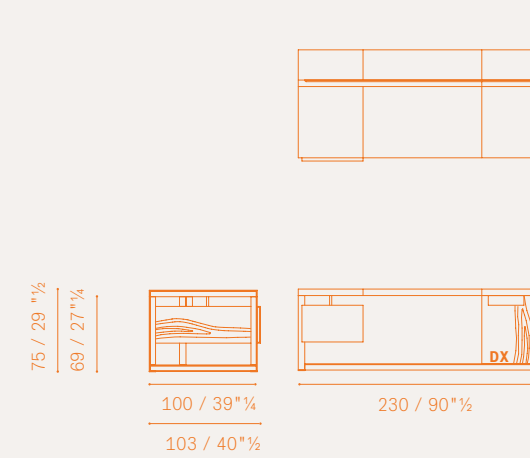

**Jobs Executive Desk** — "Guest area" in Oakwood  
5580705

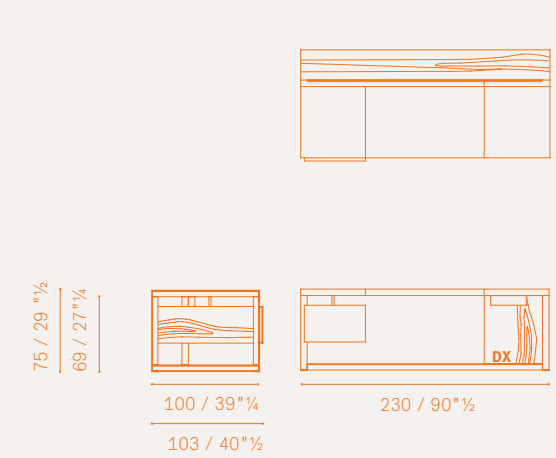

**Jobs President Desk Large** — "Guest area" in Pelle Frau® SC leather  
5580716

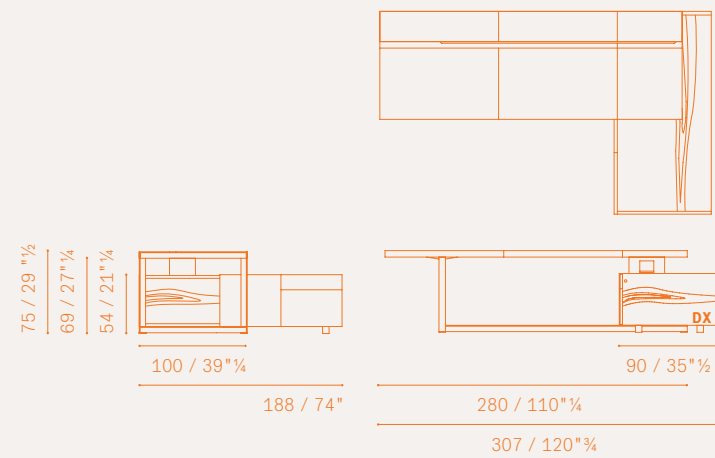

**Jobs President Desk Large** — "Guest area" in Oakwood  
5580716

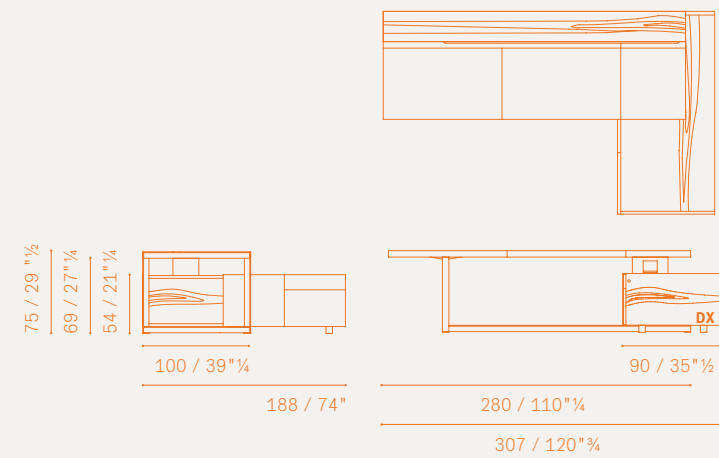

**Jobs Executive Desk with "Meeting area"** —  
"Guest area" in Pelle Frau® SC leather  
5580725

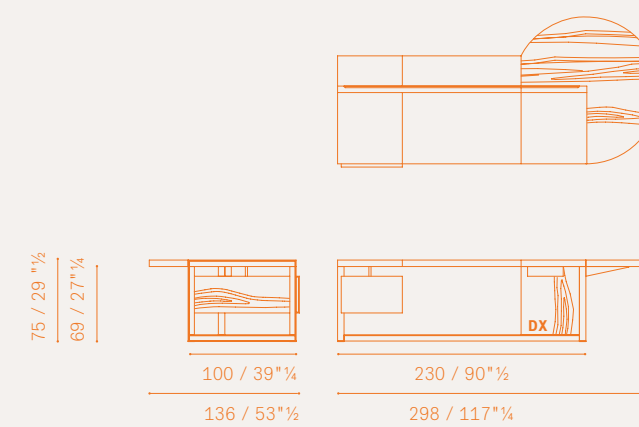

**Jobs Executive Desk with "Meeting area"** — "Guest area" in Oakwood  
5580725

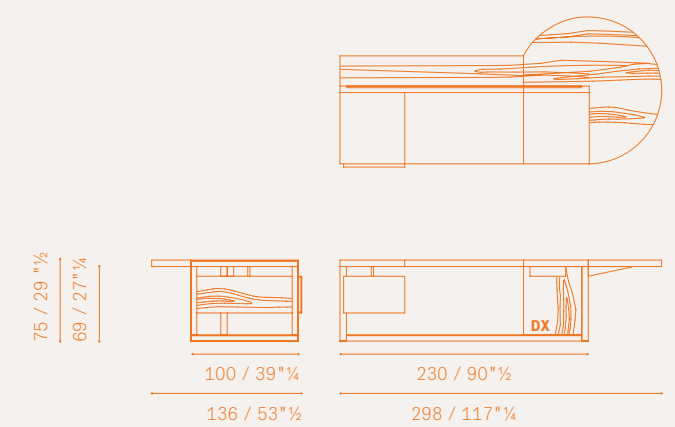

**Jobs Executive Desk Large** — “Guest area” in Pelle Frau® SC leather  
5580715

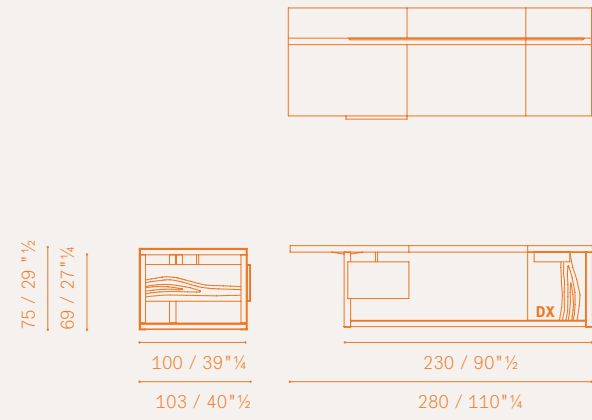

**Jobs Executive Desk Large** — “Guest area” in Oakwood  
5580715

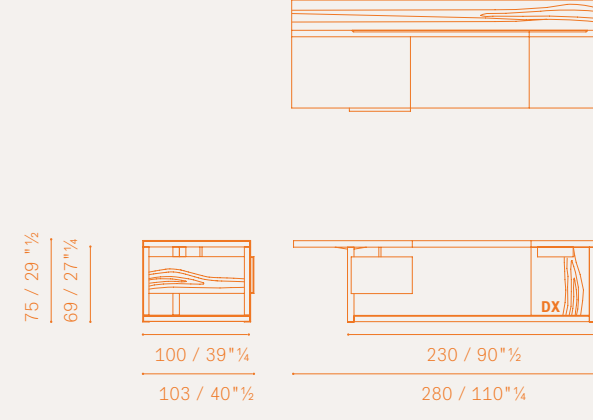

**Please note:**  
this catalogue shows only some technical drawings, in order to know all the availabilities please refer to the current price list.

**Jobs Easy Desk Large** — “Guest area” in Pelle Frau® SC leather  
5580711

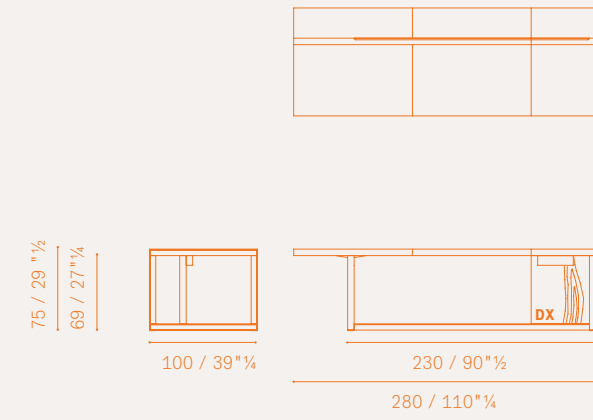

**Jobs Easy Desk Large** — “Guest area” in Oakwood  
5580711

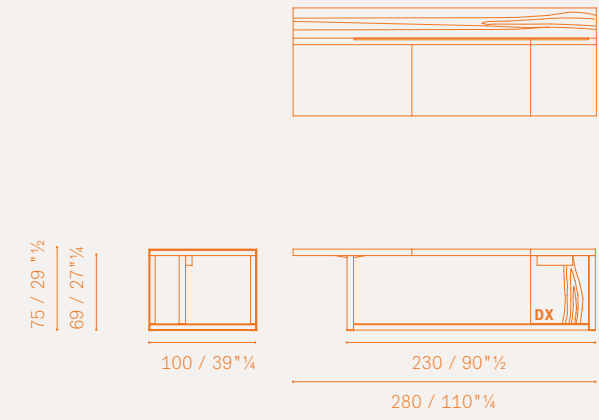

**Jobs Easy Desk** — “Guest area” in Pelle Frau® SC leather  
5580701

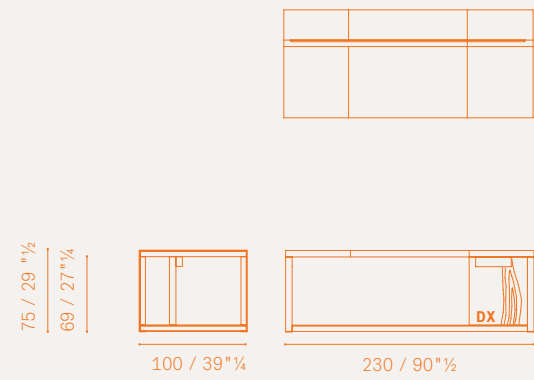

**Jobs Easy Desk** — “Guest area” in Oakwood  
5580701

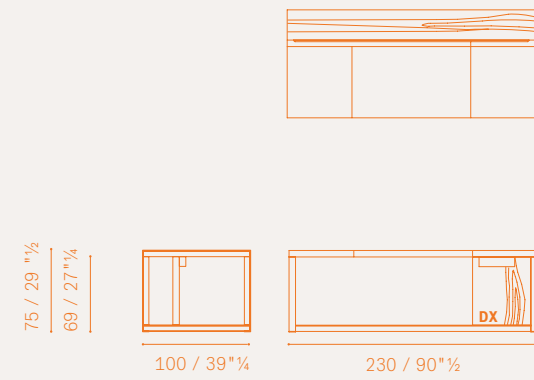

**Jobs Meeting Table 266×150 cm** — Pelle Frau® SC leather / Oakwood  
5580621

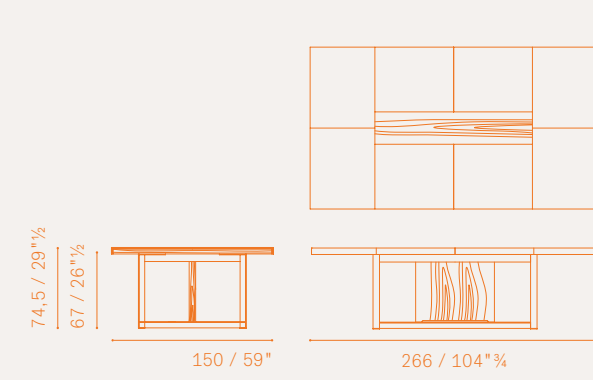

**Hardware Versions** — Meeting Table  
5580705

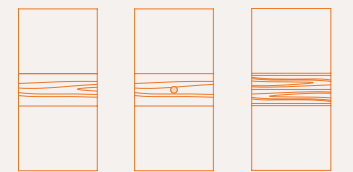

**Jobs Easy Desk with “Meeting area”** — “Guest area” in Pelle Frau® SC leather  
5580721

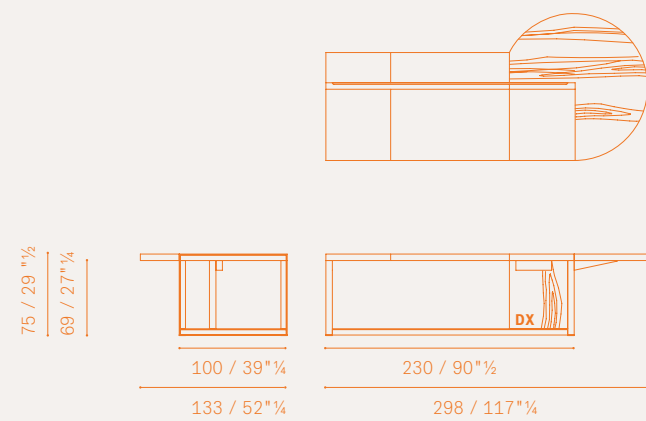

**Jobs Easy Desk with “Meeting area”** — “Guest area” in Oakwood  
5580721

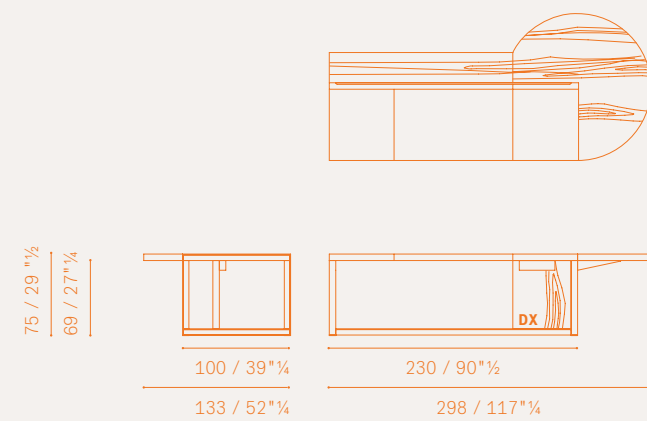

**Jobs Meeting Table 339×150 cm** — Pelle Frau® SC leather / Oakwood  
5580622

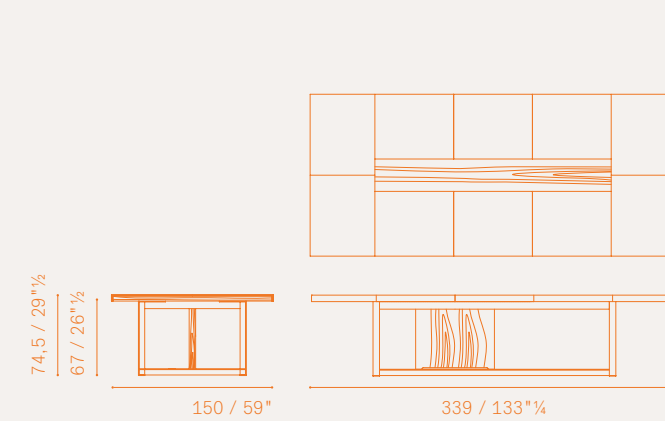

**Hardware Versions** — Meeting Table  
5580725

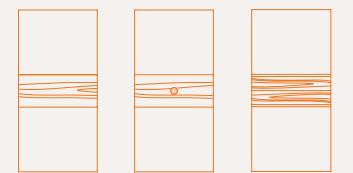

**Jobs Meeting Table 412×150 cm — Pelle Frau® SC leather / Oakwood**  
5580623

**Hardware Versions — Meeting Table**

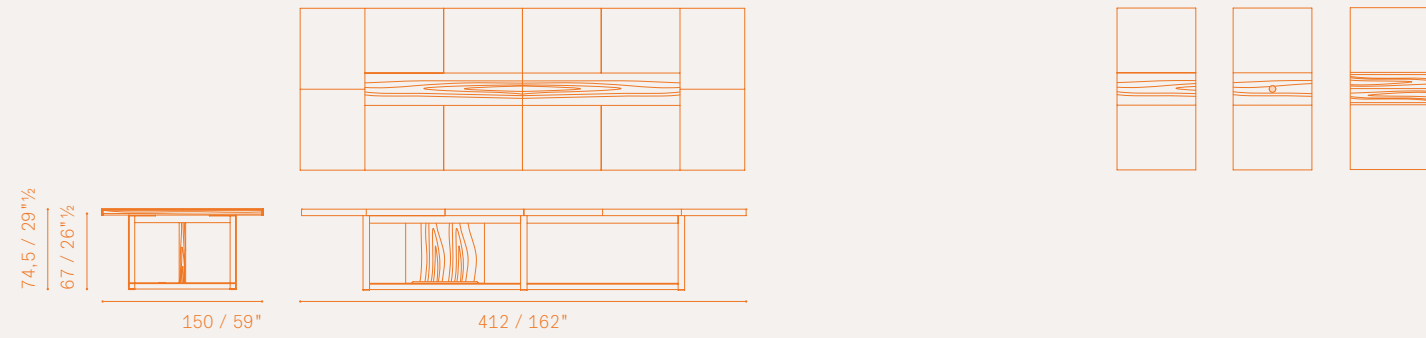

**Please note:**  
this catalogue shows only some technical drawings, in order to know all the availabilities please refer to the current price list.

**Jobs Meeting Table 631×150 cm — Pelle Frau® SC leather / Oakwood**  
5580626

**Hardware Versions — Meeting Table**

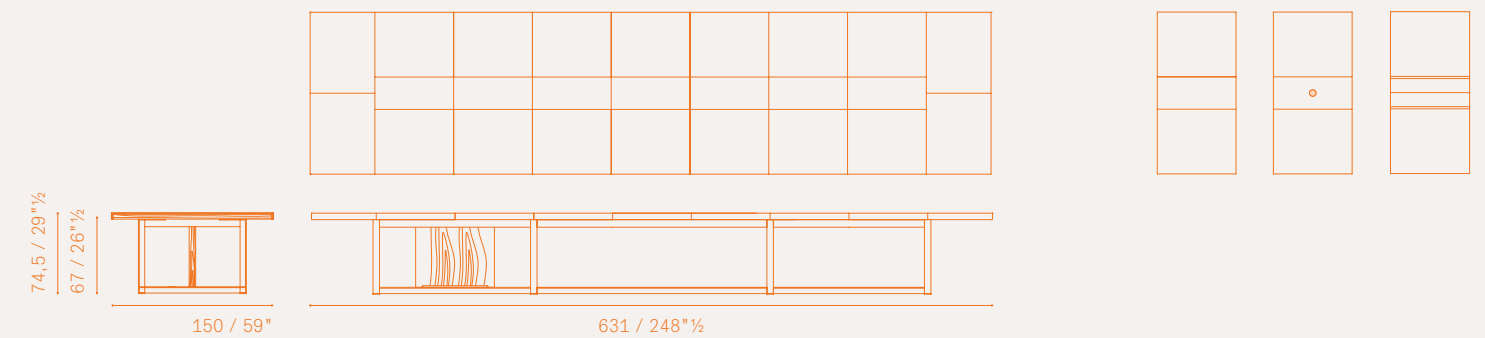

**Jobs Meeting Table 485×150 cm — Pelle Frau® SC leather / Oakwood**  
5580624

**Hardware Versions — Meeting Table**

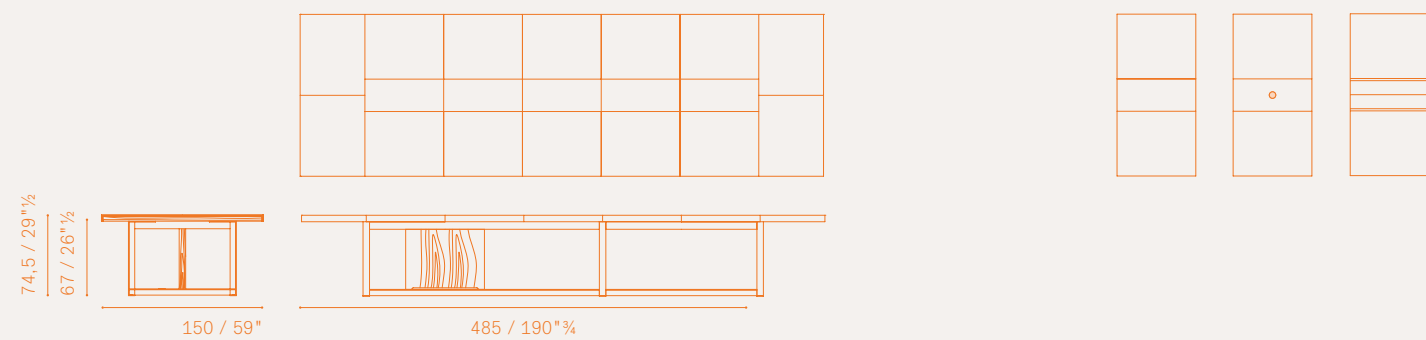

**Jobs Meeting Table 704×150 cm — Pelle Frau® SC leather / Oakwood**  
5580627

**Hardware Versions — Meeting Table**

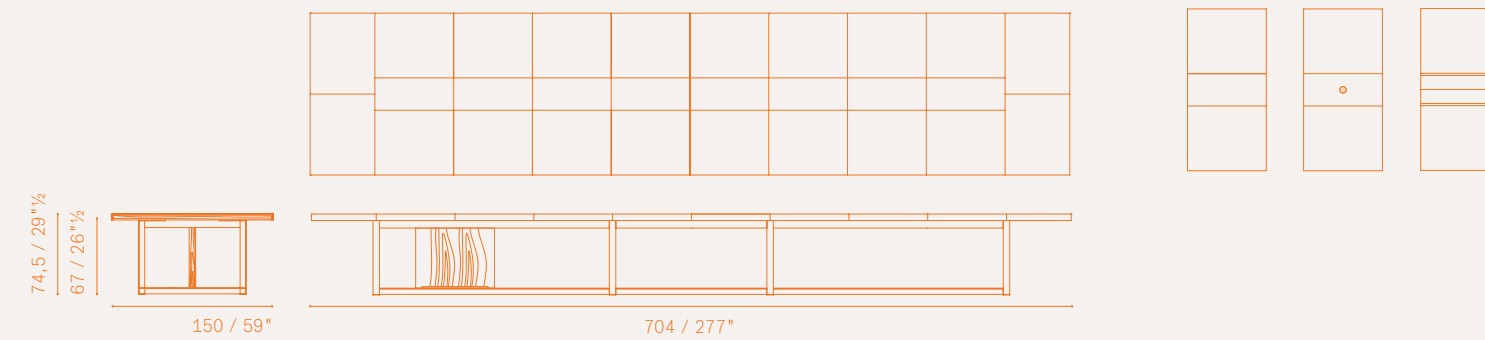

**Jobs Meeting Table 558×150 cm — Pelle Frau® SC leather / Oakwood**  
5580625

**Hardware Versions — Meeting Table**

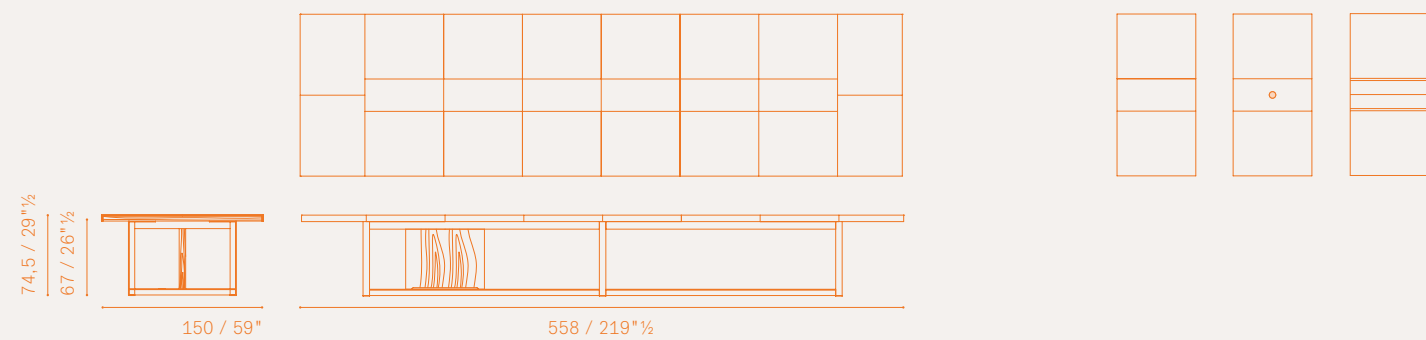

**Jobs Bookcase Freestanding 177×145 cm — Pelle Frau® SC leather / Oakwood**  
5580786

**Jobs Bookcase Freestanding 234×145 cm — Pelle Frau® SC leather / Oakwood**  
5580787

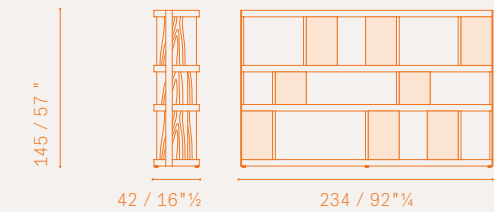
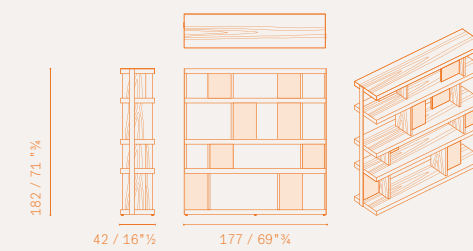



**Jobs Bookcase Wall 177×145 cm** — Pelle Frau® SC leather / Oakwood  
5580796

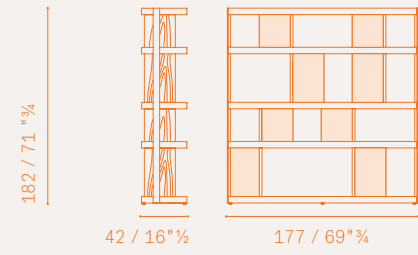

**Jobs Bookcase Wall 234×145 cm** — Pelle Frau® SC leather / Oakwood  
5580797

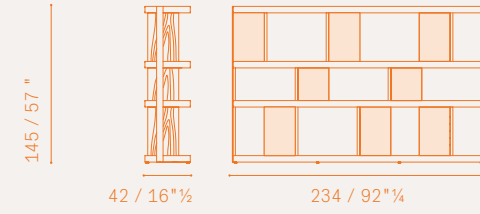

**Please note:**  
this catalogue shows only some technical drawings, in order to know all the availabilities please refer to the current price list.

**Jobs Low Cabinet 230 cm** —  
2 drawers and 2 filing cabinets / 2 compartments door  
5580781

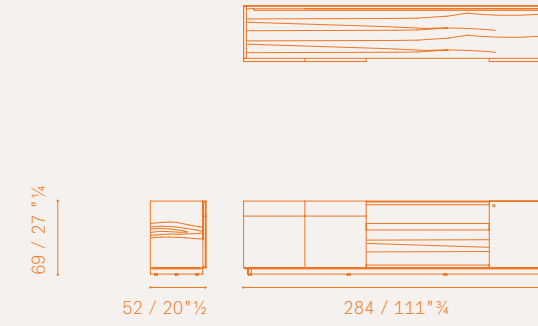

**Jobs Low Cabinet 230 cm** —  
2 drawers and 2 filing cabinets / 2 compartments door  
5580781

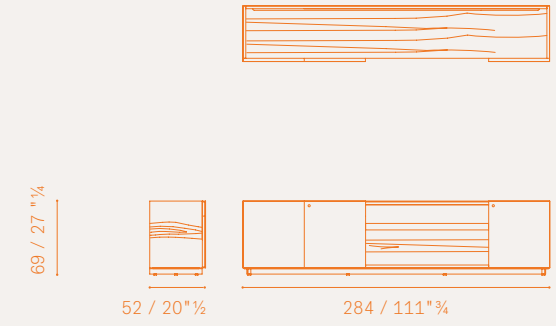

**Jobs Hight Cabinet**  
5580765

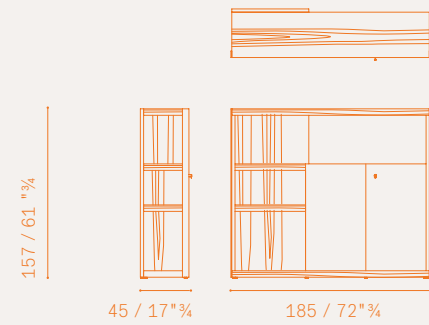

**Jobs Drawer Unit**  
5580761

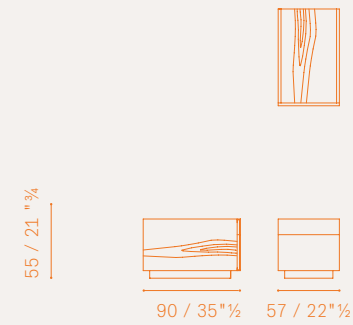

**Jobs Low Cabinet 230 cm** —  
2 drawers and 2 filing cabinets / 2 compartments door  
5580780

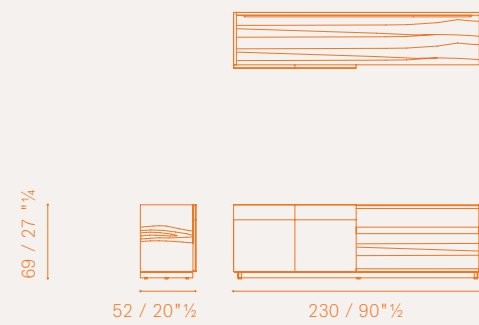

**Jobs Low Cabinet 230 cm** —  
2 drawers and 2 filing cabinets / 2 compartments door  
5580780

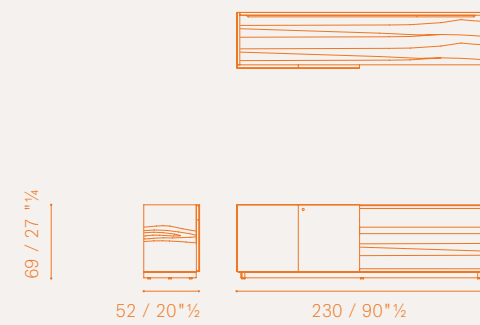

# Lella and Massimo Vignelli

## C.E.O. Cube



### LELLA E MASSIMO VIGNELLI

Lella Vignelli è nata a Udine, si è laureata in architettura a Venezia. Massimo Vignelli è nato a Milano nel 1931, ha studiato architettura a Milano e a Venezia. Svolgono attività nel campo della grafica, programmi d'immagine coordinata per l'industria, segnaletica, disegno industriale; progettano mobili, interni e allestimenti. Originariamente a Milano e dal 1965 a New York, lo studio collabora con alcune fra le più importanti industrie e istituzioni americane e europee.

### CONCEPT

La linea esprime il desiderio di superfici leggere consono alle espressioni architettoniche contemporanee. Il contrasto tra il volume della cassettera-libreria e le superfici sottili del piano di scrittura ed il pannello di supporto, conferisce alla scrivania snellezza ed autorità, elementi caratteristici del management contemporaneo. Il tavolo riunioni riprende lo stesso linguaggio in dimensioni variabili, rettangolare o tondo.

### LELLA AND MASSIMO VIGNELLI

Lella Vignelli was born in Udine and graduated in architecture in Venice. Massimo Vignelli was born in Milan in 1931 and studied architecture in Milan and Venice. Their work includes graphic design, corporate image work for industry, signs and industrial design; they design furniture, interiors and exhibition installations. Originally based in Milan and since 1965 in New York, the studio works with some of the most important American and European companies and institutions.

### CONCEPT

The series epitomises the desire for light surfaces that are in keeping with contemporary architectural expression. The contrast between the volume of the drawer chest-bookcase and the slender surfaces of the desktop and the supporting panel gives the desk a streamlined and authoritative feel, distinctive characteristics of contemporary management. The meeting table adopts the same language in variable dimensions, rectangular or round.

### LELLA AND MASSIMO VIGNELLI

Lella Vignelli レッラ・ヴィニェッリはウディネで生まれ、ヴェネツィアで建築学の学位を取得。Massimo Vignelli マッシモ・ヴィニェッリ (1931-2014) はミラノで生まれ、ミラノとヴェネツィアで建築を学ぶ。Vignelliヴィニェッリ・アソシエイツ・スタジオをミラノで創設、1965 年ニューヨークに移りアメリカやヨーロッパの有名企業や団体の仕事を手掛ける。二人はグラフィック、コーポレート・イメージ、ロゴやシンボル・マークのデザイン、インダストリアル・デザインの分野で活躍。オブジェ、家具調度品、インテリア、展示会場のデザイン設計も手掛けている。

### コンセプト

スリムさで特徴を出す現代的な構成のデザイン。引き出しと本棚のキャビネットのボリュームとデスクの天板とそれを支えるパネルの薄さのコントラストが現代のエグゼクティブに求められるスマートさと威厳を感じさせる。会議用テーブルも同じコンセプトでデザインされ、長方形、正方形、円形、サイズも豊富。

### LELLA AND MASSIMO VIGNELLI

Lella Vignelli 出生于意大利乌迪内，毕业于威尼斯建筑学院。Massimo Vignelli (1931-2014) 出生于米兰，并在米兰和威尼斯深造建筑学。一开始活跃于米兰，1965 年起把工作重心 转移到纽约，Vignelli 联合设计工作室与各个重量级的欧美公司都有着密切的合作关系。Lella 和 Massimo Vignelli 的工作范畴包括 图形设计、企业形象设计、标志及工业设计；同时他们也涉足配饰、家具、室内与展会装置设计。

### 理念

这一全新系列集中体现了对轻盈外观的渴望，表达建筑的当代性。抽屉柜与书柜的巨大体量与纤薄的桌面形成了鲜明反差，配合支撑侧板的设计，赋予这款办公桌流畅的外观与庄重的气场，塑造了一个当代管理者的性格特征。会议桌的理念也如出一辙，长方形、正方形或圆形的桌面款式有多种尺寸可供选择。



↑ C.E.O. Cube President Desk — Furniture Unit ↗ lower top and leg detail



Collezioni Ufficio — C.E.O. Cube

Office Collections — C.E.O. Cube

エグゼクティブシステムズ — C.E.O. Cube

蟹 樽様 鎌 匠 匠 — C.E.O. Cube







↑ C.E.O. Cube Meeting Table Hardware with central doors — Top and leg detail ↗ President Area

# C.E.O. Cube Materials

La forma pura, la sintesi della materia, la solidità di una struttura tecnicamente avanzata. L'essenzialità geometrica unita all'esaltazione dei materiali, la Pelle Frau®, il legno, le leghe di alluminio.

## PELLE FRAU® COLORSPHERE®

Materia principale della serie C.E.O. Cube, la Pelle Frau® ColorSphere® esalta l'architettura dei tavoli riunione, delle scrivanie direzionali, dei contenitori e della libreria con vani a giorno. 73 possibili colori di pelle con cui rivestire il sottomano delle scrivanie o l'intero piano di lavoro, in abbinamento o in contrasto, il mobile cubo e il pannello di cortesia. Ma anche gambe e piano dei tavoli meeting, la cassettera, i cabinet e la bookcase sono interamente rivestiti in pelle.

## NOCE CANALETTO

Finitura esclusiva delle desk, il noce Canaletto può essere scelto per le fasce laterali del piano di lavoro diversificandolo dal sottomano in pelle. In questo caso anche le gambe sono in essenza come il piano.

## ALLUMINIO LUCIDO

I dettagli che fanno la differenza. Il cubo che sostiene un lato della scrivania è dotato di due cassetti e un classificatore con maniglie in alluminio lucido completi di serratura. Sul lato esterno è dotato di un vano a giorno interamente rivestito in pelle e diviso da una griglia di ripiani in alluminio lucido. Anche il pannello di cortesia, rivestito in pelle, è in alluminio.

The pure form, the blend of materials, the solid, technically-advanced structure, the soul of Poltrona Frau. A combination of clear-cut geometric design and fine materials, from noble Pelle Frau® leather to wood and aluminium alloys.

## PELLE FRAU® LEATHER FROM THE COLORSPHERE®

The main material of the C.E.O. Cube series, the Pelle Frau® leather from the ColorSphere® exalts the architecture of the meeting tables, the executive desks, the storage units and the bookcase with open compartments. 73 possible colours of leather with which to upholster the desk pad or the entire desktop, matching or contrasting, the cube and the modesty panel. The legs and the surface of the meeting tables, the drawer chest, the cabinets and the bookcase are also completely upholstered in leather.

## CANALETTO WALNUT VENEER

An exclusive finish for the desks, the Canaletto walnut veneer can be chosen for the edges of the work surface to differentiate them from the leather desk pad. In this case the legs are also in wood, like the desk surface.

## POLISHED ALUMINIUM

It is the details that make the difference. The cube that supports one side of the desk is fitted with two drawers and a filing cabinet with handles in polished aluminium, complete with lock. Externally, there is an open compartment entirely upholstered in leather divided up by a grid of polished aluminium shelves. The leather-upholstered modesty panel is also in aluminium.

すっきりとしたフォルム、先進的技術を駆使した構築の中で異素材の組合せを活かす。エッセンシャルなデザインが Pelle Frau® ペッレ・フラウ、ウッド、アルミニウムという素材の美しさを際立たせる。

## PELLE FRAU® COLORSPHERE® ペッレ・フラウ® カラー・システム

C.E.O. Cube の主な素材である Pelle Frau® ColorSphere® ペッレ・フラウ® カラー・システムが会議用テーブル、エグゼクティブ・デスク、キャビネット類、本棚のデザインの美しさを際立たせる。立方体および使用者の脚を隠す目隠しパネルの革張りと同色又はコントラスト・カラーを73色の中から選び、デスクパッドやテーブルトップ全体を革張りする事が可能。会議用テーブルの脚、天板、引き出し、キャビネット、ブックケースも総革張り。

## NOCE CANALETTO カナレット・ウォールナット

デスクの高級仕上げ。革張りのデスクパッドを中心に、天板の両サイドの帯状部分に Canaletto カナレット・ウォールナットを組み合わせる事もできる。この場合、脚もウッドとなる。

## 光沢仕上げのアルミニウム

違いはディテールから生まれる。デスクの片側を支える立方体には光沢仕上げアルミ製の取っ手が付いた引き出しが2つとファイリング・キャビネットが付いており、錠前付き。外側に向いた面は覆いが無く、総革張りで、光沢仕上げアルミニ製の格子状棚板で仕切られている。使用者の脚を隠すための目隠しパネルもアルミ製の革張り。

纯粹的外形，丰富的材质，扎实高科技的框架结构，汲取 Poltrona Frau 的精髓。这款桌子是简洁剪裁的几何外形设计与精细材质的完美结合，从引以为豪的 Pelle Frau® 皮革到木材，再到铝合金。

## PELLE FRAU® 色彩系统中的皮革

C.E.O. Cube 系列中最主要的材质便是从 Pelle Frau® 色彩系统中精选出的皮革，进一步提升了会议桌、办公桌、储物单元以及开放式的书柜单元的建筑感。73 种皮革色彩可供挑选，用来包裹桌面的写字区域，甚至是整张桌面，即可以同色，也可以玩转对比撞色，为立方体的储物柜或朴实的侧板选择不同色彩。会议桌、抽屉柜、储物柜以及书柜的支撑脚和表面均包裹皮革。

## CANALETTO WALNUT VENEER CANALETTO 胡桃木贴皮

作为这款办公桌的独特饰面，Canaletto 胡桃木贴皮可以适用于办公区域表面的边缘，用来与写字区域做区隔。在这个款式中，桌脚会采用与桌面一样的木饰面。

## POLISHED ALUMINIUM 抛光铝合金

细节制胜，与众不同。支撑办公桌一侧的立方体单元配备有2个抽屉与1个文件抽，均使用抛光铝质把手，并安装了锁扣系统。不仅如此，我们还额外设计了一个开放式的储物单元，全部包裹皮革，内置网格状的铝合金搁板隔断。在皮革包裹下的侧板也为铝合金材质。





## C.E.O. Cube Desk

Le scrivanie Desk hanno struttura asimmetrica con telaio portante in tubolare e traverse di lamiera di metallo. Nelle foto, il rivestimento della Desk è tutto in Pelle Frau® SC 56 Siena.

The Desks are asymmetric in design with supporting structure in tubular metal and crossbars in sheet metal. In the photos, the Desk is entirely upholstered in SC 56 Siena Pelle Frau® leather.

Desk デスクはアシンメトリー、パイプ材の支柱とメタル製の板の梁で支えている。写真の Desk の革張りは Pelle Frau® SC 56 Siena ベッレ・フラウ® SC 56 シエナ。

这款办公桌拥有不对称的设计，支撑结构为管状金属以及由金属片组成的横档组成而成。图示款中，办公桌整体包裹 SC 56 Siena Pelle Frau® 皮革。

Il piano e la gamba sono realizzati con doppia pannellatura a bordo smussato, rivestiti sul lato esterno in Pelle Frau® del ColorSphere® oppure impiallacciati in noce Canaletto. Il sottomano è sempre in pelle.

The desktop and leg are produced with double-panelling with rounded edges, upholstered on the outside with Pelle Frau® leather from the ColorSphere® or finished in Canaletto walnut veneer. The desk pad is in leather.

天板と脚はパネルを二重にしており、縁に丸みをつけている。外側は Pelle Frau® del ColorSphere® カラー・システムのベッレ・フラウ® で革張り又は Canaletto カナレット・ウォールナット。デスクパッドは常に革張り。

桌面与桌腿采用圆滑棱角的双面镶板制造而成，外侧包裹从 Pelle Frau® 的色彩系统中精选出的皮革，或选用 Canaletto 胡桃木贴皮。写字区域为皮革软包。

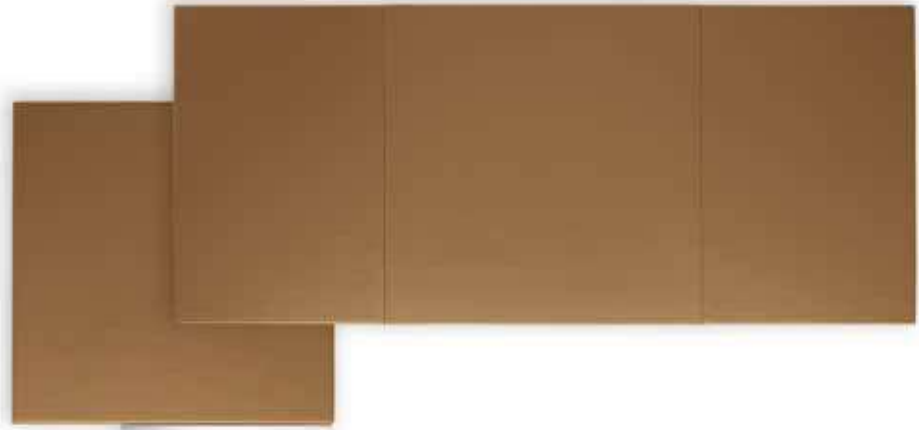

Nella foto il rivestimento della desk è in Pelle Frau® SC 23 Tortora per sottomano e cubo. I pannelli laterali del piano di lavoro e la gamba sono impiallacciati in noce Canaletto. Qui nella versione con pannello di cortesia.

In the photo, the desk pad and cube are upholstered in SC 23 Tortora Pelle Frau® leather. The lateral panels of the desktop and the leg have a Canaletto walnut veneer. This version comes with modesty panel.

写真の Desk のデスクパッドと立方体の革張りは Pelle Frau® SC 23 Tortora ベッレ・フラウ® SC 23 トルトラ。テーブルトップのサイド・パネルと脚は Canaletto カナレット・ウォールナット。写真の製品は使用者の脚を隠すための目隠しパネル付。

图示款中，桌面的写字区域与储物立方体包裹 SC 23 Tortora Pelle Frau® 皮革。桌子的侧板与桌腿为 Canaletto 胡桃木贴皮。此款办公桌为带背板式。

Il cubo che sostiene un lato della scrivania è dotato di un sistema che consente la rotazione su se stesso e può essere montato a destra o a sinistra della scrivania.

The cube that supports one side of the desk is fitted with a system allowing it to rotate about itself, and can be mounted on the left or right of the desk.

デスクの片側を支える立方体は軸を中心として回転するので、デスクの右側にも左側にも取り付けの事が可能。

以储物立方体为桌面一边支撑的款式中，安装了中轴系统，可以让立方体围绕自身轴心旋转，也可以根据需要安装在桌子的左侧或右侧。

## C.E.O. Cube Desk



## C.E.O. Cube Easy Desk

Nella foto, scrivania Easy Desk in noce Canaletto con sottomano rivestito in Pelle Frau® SC 23 Tortora

In the photo, Easy Desk with Canaletto walnut veneer and desk pad in Pelle Frau® SC 23 Tortora leather.

写真の製品は Canaletto カナレット・ウォールナットの Easy Desk、デスクパッドの革張りは Pelle Frau® SC 23 Tortora ベッレ・フラウ® SC 23 トルトラ。

图示款中，这款电脑桌为Canaletto胡桃木贴皮，写字区域覆盖 Pelle Frau® SC 23 Tortora 皮革。



L'Easy Desk ha una struttura a "C" rovesciata e può essere attrezzata con una cassettera con ruote.

The Easy Desk has an upturned "C" structure and can be equipped with an additional wheeled drawer unit.

Easy Desk は "C" を逆にした形、キャスター付の引き出しキャビネットを加える事も可能。

这款电脑桌外形设计为一个上下翻转的倒 "C" 型结构，还可以额外配备一个带脚轮的抽屉柜。



## C.E.O. Cube Easy Desk

Nella foto sopra la scrivania Easy Desk è rivestita in Pelle Frau® bicolore: piano di lavoro e gambe in SC 65 Vachette e sottomano in Pelle Frau® SC 69 Iroko.

In the above photo the Easy Desk is upholstered in two-tone Pelle Frau® leather: desktop and legs in SC 65 Vachette leather and desk pad in SC 69 Iroko leather.

写真の Easy Desk の革張りは Pelle Frau® bicolore ベッレ・フラウ® のバイカラー。天板と脚の色は SC 65 Vachette カンネッラ、デスクパッドの色は Pelle Frau® SC 69 Iroko ベッレ・フラウ® SC 69 イロコ。

上图所示的电脑桌款式包裹双色拼接的 Pelle Frau® 皮革：分别是桌面与桌腿的部分为 SC 65 Vachette 皮革，写字区域为 SC 69 Iroko 皮革。



Nella foto sotto la scrivania Easy Desk è totalmente rivestita in Pelle Frau® SC 65 Vachette.

In the photo below the Easy Desk is entirely upholstered in SC 65 Vachette Pelle Frau® leather.

下の写真の Easy Desk は Pelle Frau® SC 65 Vachette ベッレ・フラウ® SC 65 Vachette カンネッラで全体を革張り。

下图所示的电脑桌款式整体包裹 SC 65 Vachette Pelle Frau® 皮革。



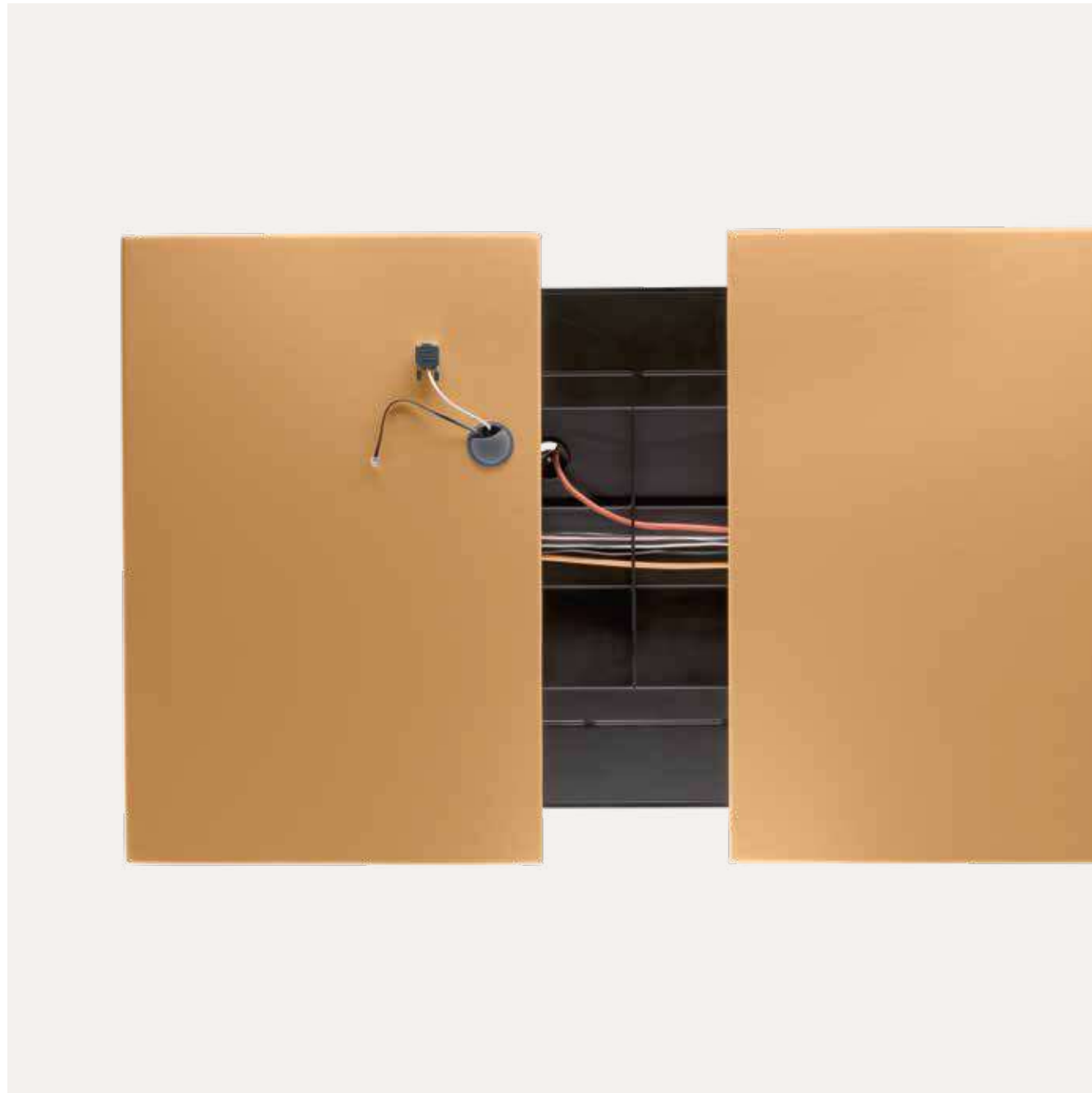

Vista zenitale del piano di lavoro della scrivania con dettaglio del vano adibito al passaggio cavi e della fuoriuscita sul piano attraverso una borchia metallica.

Overhead view of the desktop with detail of the compartment designed to accommodate cables and their emergence on the tabletop through the use of a metal grommet.

デスクの天板を上から見ると配線のためのコードが通るスペースと天板に抜ける部分のメタル・パーツが見て取れる。

桌面顶视图，俯视电线收纳部件设计，通过使用金属环扣可以使线缆通到桌面上。

C.E.O. Cube Desk — Dettaglio tecnico del passaggio cavi — Technical details of the cable management — ケーブル配線に関する技術的詳細 — 电缆管道的技术细节

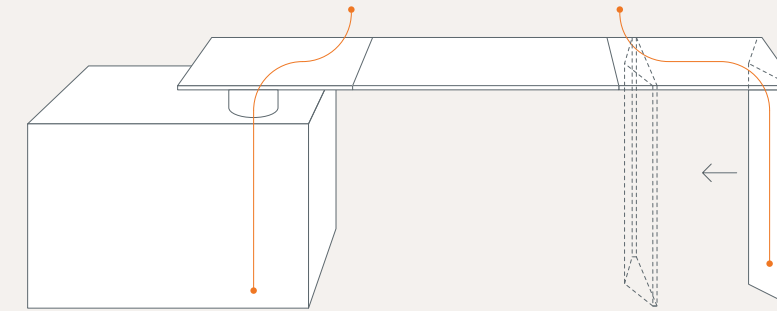

C.E.O. Cube Easy Desk — Dettaglio tecnico del passaggio cavi — Technical details of the cable management — ケーブル配線に関する技術的詳細 — 电缆管道的技术细节

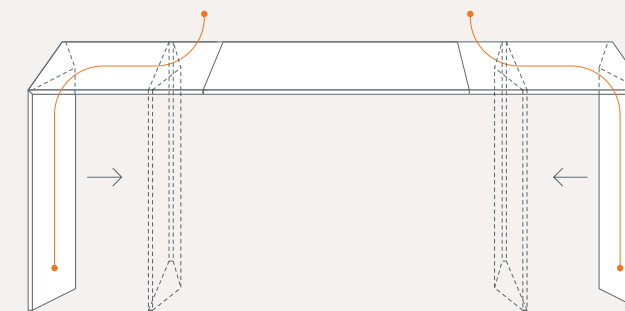



## C.E.O. Cube Round Meeting Table ø180cm / ø150cm

Tutti i tavoli Meeting hanno grandi gambe cilindriche in tubolare metallico, leggermente imbottite e rivestite in pelle. La versione rotonda è disponibile in due dimensioni, Ø 180 cm e Ø 150 cm, h. 75 cm.

Nelle foto il rivestimento è in Pelle Frau® SC 28 Seppia per la versione grande e SC 128 Carminio per la versione più piccola.

All of the Meeting tables have large cylindrical tubular metal legs, lightly padded and upholstered in leather. The round version is available in two sizes, Ø 180 cm and Ø 150 cm, h. 75 cm. In the photos the large version is upholstered in SC 28 Seppia Pelle Frau® leather and the smaller version in SC 128 Carminio leather.

すべてのMeeting テーブルには中空のメタル製円筒に薄くパッドを巻いて革張りした脚が付いている。円形のモデルには2つのサイズ、Ø 180 cm と Ø 150 cm。それぞれ高さは 75 cm と 50 cm。写真の製品の大きいサイズの革張りは Pelle Frau® SC 28 Seppia ベレ・フラウ® SC 28 セピア、小さいサイズは SC 128 カルミニオ。

所有的会议桌都拥有圆柱形金属桌腿，部分以皮革软包加以装饰点缀。圆形的款式有两种尺寸可供选择，分别是 Ø 180 cm 和 Ø 150 cm，它们的高度是 h. 75 cm。图片中，大尺寸办公桌的装饰是 SC 28 Seppia Pelle Frau® 皮革；而小尺寸办公桌则的装饰是 SC 128 Carminio 皮革。



210 cm o 120 cm. Entrambi i cabinet sono dotati di ante apribili con leggera pressione e hanno l'interno dei vani ed il retro laccati nero opaco. Top, fianchi ed ante rivestiti in Pelle Frau® ColorSphere®. Il rivestimento dei cabinet nelle foto è in Pelle Frau® SC 92 Garnet

210 cm or 120 cm. Both cabinets have touch-latch doors and the interiors and the backs are painted in matt black. Top, sides and doors are upholstered in Pelle Frau® leather from the ColorSphere®. The cabinets in the photos are upholstered in SC 92 Garnet Pelle Frau® leather.

210 cm もしくは 120 cm。どちらのキャビネットも軽く押しただけで開く扉。内部と裏側はマットなブラック塗装。外側はトップもサイドも扉も Pelle Frau® ColorSphere® カラー・システムのベッレ・フラウ® で革張り。写真のキャビネットの革張りは Pelle Frau® SC 92 Garnet ベッレ・フラウ® SC 250 Vermillon リーブス。

210 cm 或 120 cm 两种尺寸的橱柜。任意一种款式都配备推弹柜门，内部表面以及背板涂刷黑色哑光漆。顶面、侧边以及柜门都软包从 Pelle Frau® 的色彩系统中精选出皮革。图示款的橱柜为软包 SC 92 Garnet Pelle Frau® 皮革。

## C.E.O. Cube Low Cabinet / Small Cabinet



## C.E.O. Cube Modular Meeting Table

Il piano dei tavoli Meeting è leggermente imbottito e supportato da un pannello inferiore in fibra di legno verniciato nero texturizzato e predisposto per il passaggio cavi. Nel vano interposto e sulle cavità delle gambe sono predisposti specifici alloggiamenti per i cablaggi. Nelle foto il tavolo è in Pelle Frau® SC 31 Quarzo Fumé.

The surface of the Meeting tables is lightly padded and supported by a wood fibre panel below in a textured black finish designed to accommodate cables. The compartment and hollow legs have been specifically designed to accommodate cables. In the photos, the table is upholstered in SC 31 Quarzo Fumé Pelle Frau® leather.

会議用テーブルの天板は薄いパッド入りで、ウッド・ファイバー板にブラック塗装とテクスチャーを施したパネルで下から支え、配線を通すこともできるようになっている。配線を通すスペースや脚の窪みには配線用の溝が切り込んである。写真のテーブルの革張りはベレ・フラウ® SC 31 クアルツォ・フュメ。

这款会议桌的表面以皮革软包稍加修饰，底下由木纤维板支撑，表面为黑色纺织纹理饰面，预先设计有电线收纳功能。隔断与中空桌腿都是特别设计用来收纳或通过线缆。图示款为整体包裹 SC 31 Quarzo Fumé Pelle Frau® 皮革。

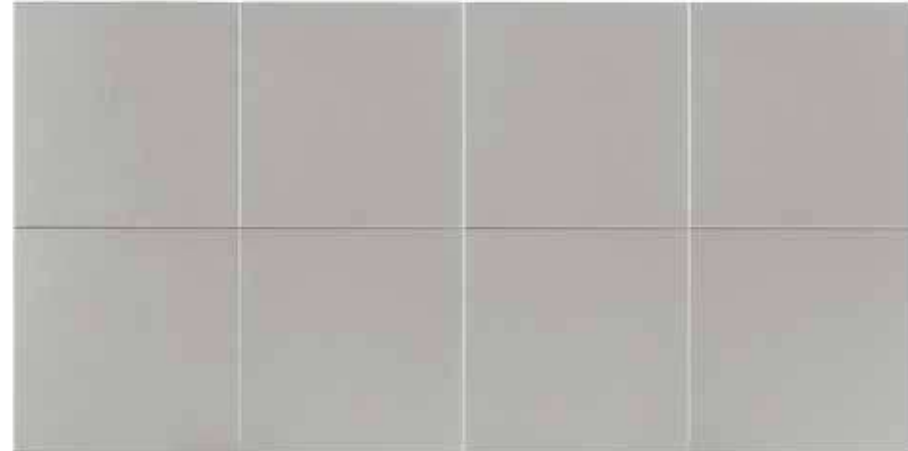

I tavoli da riunione modulari, nelle versioni rettangolare e ovale, sono disponibili in sette diverse dimensioni che spaziano da 296 cm a 734 cm. Nelle foto il rivestimento è in Pelle Frau® SC 31 Quarzo Fumé.

The modular meeting tables, in the rectangular and oval versions, are available in seven different sizes ranging from 296 cm to 734 cm. In the photos they are upholstered in Pelle Frau® SC 31 Quarzo Fumé leather.

モジュラー式会議用テーブルには長方形とオーバルがあり、296 cm から 734 cm まで 7 つのサイズが用意されている。写真の製品の革張りは Pelle Frau® SC 31 Quarzo Fumé ベッレ・フラウ® SC 31 Quarzo Fumé カルツォ・フュメ。

模块化的会议桌，长方形及椭圆形的款式分别有从 296 cm 到 734 cm 的 7 种不同尺寸可供挑选。图示款为包裹 SC 31 Quarzo Fumé Pelle Frau® 皮革。

Tavolo rettangolare con President Area rivestita in Pelle Frau® SC 28 Seppia.

Rectangular meeting table with President Area upholstered in SC 28 Seppia Pelle Frau® leather.

Pelle Frau® SC 28 Seppia ベッレ・フラウ® SC 28 セビアでプレジデント・エリアを革張りした長方形のモデル。

长方形款，行政区域包裹 SC 28 Seppia Pelle Frau® 皮革。

## C.E.O. Cube Modular Meeting Table Oval / Rectangular



# C.E.O. Cube Modular Meeting Table Hardware

Con pannelli centrali

With central panels

センター・パネルから

中央面板

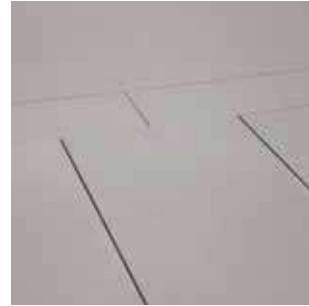

Con pannelli centrali e borchie passacavi

With central panels and cable tidy grommets

センター・パネルと配線用メタル・パーツを通して

带电线收纳管的中央面板



Con sportelli centrali

With central doors

センターの開口部から

可开合中央面板



Sono disponibili 4 versioni: la versione standard con piano semplice e 3 versioni Hardware diversamente attrezzabili per il passaggio dei cavi elettrici.

They are available in 4 versions: the standard version with straightforward surface and 3 Hardware versions that can be furnished in different ways to accommodate electrical cables.

4つのバージョンが用意されている: スタンダード・バージョンはシンプルな天板、ハードウェア・バージョンが3種類あり、それぞれ配線の通し方が異なる。

有4种款型可供挑选: 标准款为平直的桌面设计, 另有3款可按照不同摆放需要安装相应五金件, 用来收纳电线, 它们分别是。



C.E.O. Cube Meeting Table - Dettaglio tecnico del passaggio cavi - Technical details of the cable management - ケーブル配線に関する技術的詳細 - 电缆管道的技术细节

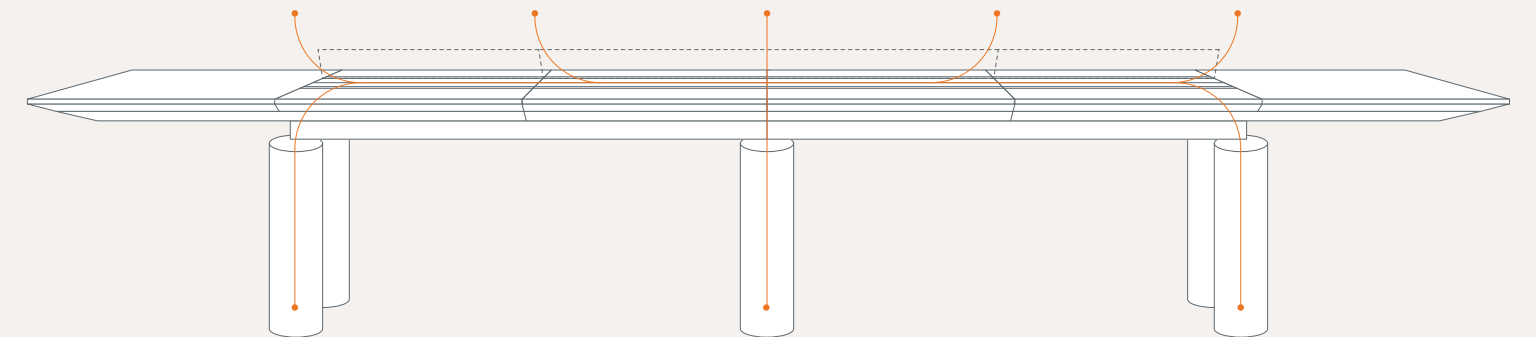



## C.E.O. Cube Modular Meeting Table Hardware

Vista in sezione del piano di lavoro di un tavolo riunione versione Hardware con sportelli con evidenza del vano sotto piano predisposto per accogliere i cavi.

Cross-section of the work surface of a Hardware version meeting table with doors, highlighting the compartment located under the tabletop designed to accommodate cables.

ハードウェアバージョンの会議用テーブルの開口部がある天板の断面。天板の下に配線を通すスペース。

此图为带开合面板的会议桌款式中，工作台面的横截面，突出了安装在台台下用来收纳线缆的隔断细节。



**C.E.O. Cube Easy Desk** — Pelle Frau® SC leather

5175606

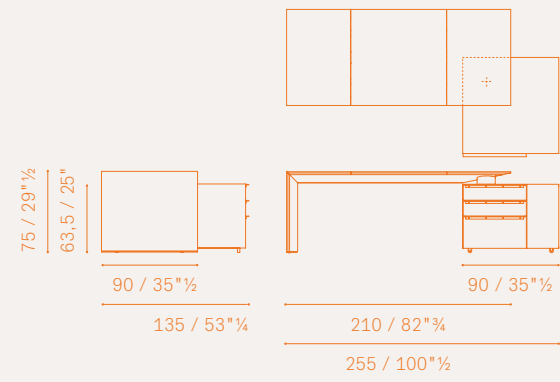

**C.E.O. Cube Easy Desk** — Canaletto walnut / Pelle Frau® SC leather

5175601

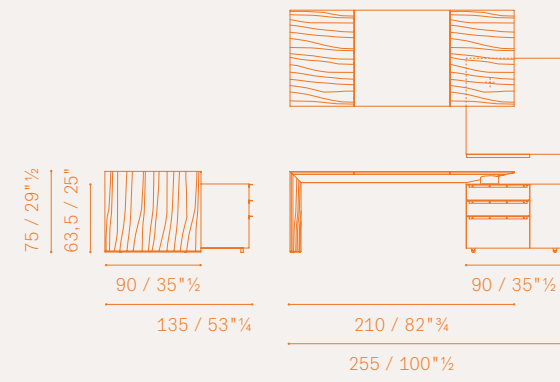

**Please note:**

this catalogue shows only some technical drawings, in order to know all the availabilities please refer to the current price list.

**C.E.O. Cube Easy Desk with modesty panel** — Pelle Frau® SC leather

5175606

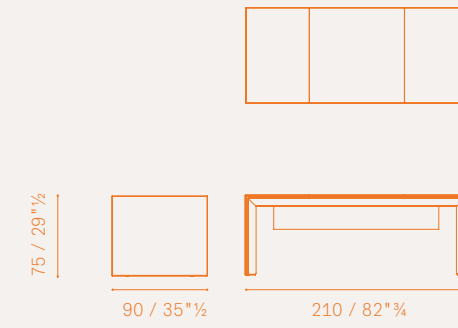

**C.E.O. Cube Easy Desk with modesty panel** — Canaletto walnut / Pelle Frau® SC leather

5175606

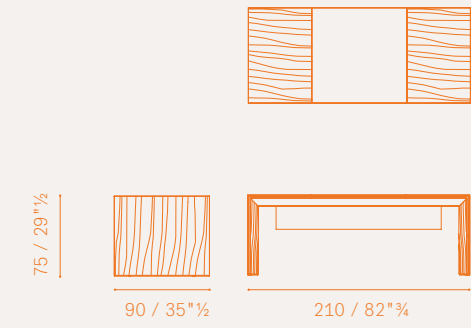

**C.E.O. Cube Desk with modesty panel** — Pelle Frau® SC leather

5175601

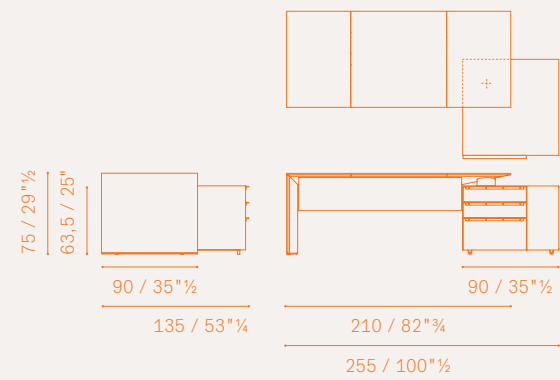

**C.E.O. Cube Desk with modesty panel** — Canaletto walnut / Pelle Frau® SC leather

5175606

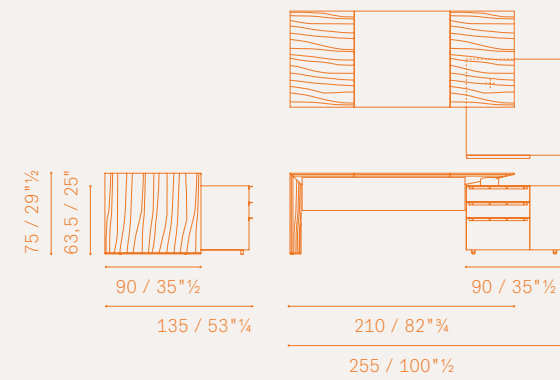

**Stationary Tray drawer insert**

5580705

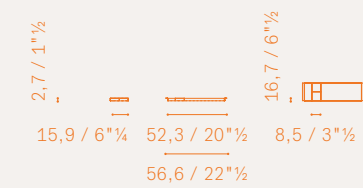

**C.E.O. Cube Desk** — Pelle Frau® SC leather

5175601

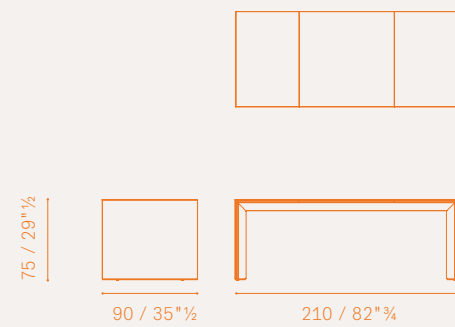

**C.E.O. Cube Desk** — Canaletto walnut / Pelle Frau® SC leather

5175601

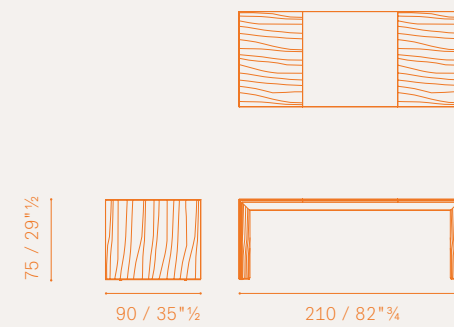

**C.E.O. Cube Meeting Table Round meeting table ø 180** — Pelle Frau® SC leather

5175632

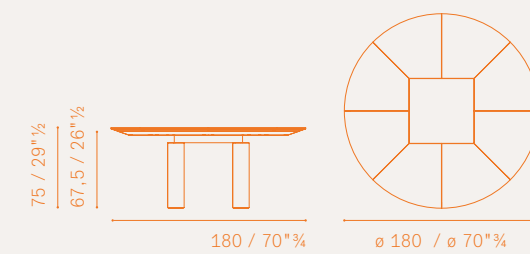

**C.E.O. Cube Meeting Table Round meeting table ø 150** — Pelle Frau® SC leather

5175631

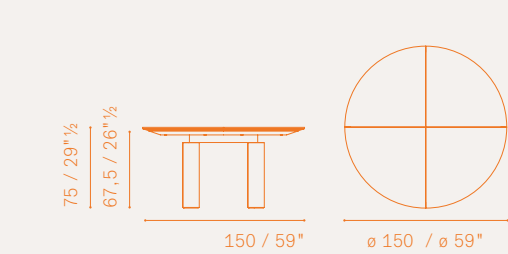

# C.E.O. Cube

C.E.O. Cube Meeting Table 296×150cm Oval / Rectangular / with President Area — Pelle Frau® SC leather

Hardware Versions Meeting Table

5175621 Rectangular  
5175636 Oval

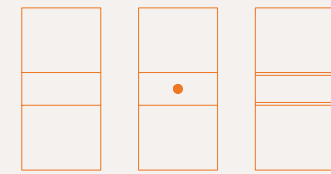
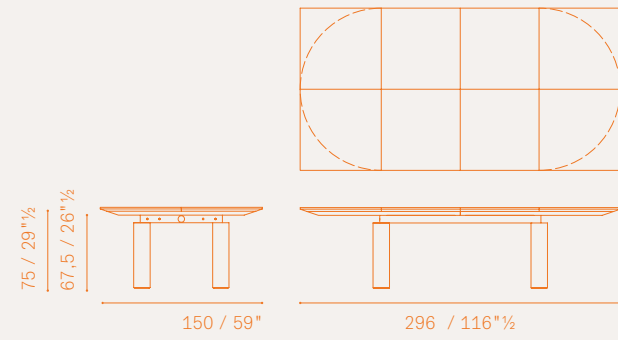

C.E.O. Cube Meeting Table 661×150cm Oval / Rectangular / with President Area — Pelle Frau® SC leather

Hardware Versions Meeting Table

5175622 Rectangular  
5175637 Oval

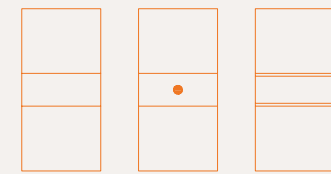
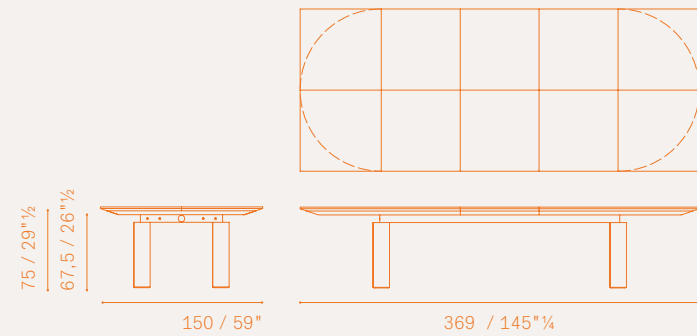

C.E.O. Cube Meeting Table 515×150cm Oval / Rectangular / with President Area — Pelle Frau® SC leather

Hardware Versions Meeting Table

5175621 Rectangular  
5175636 Oval

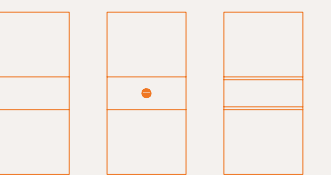
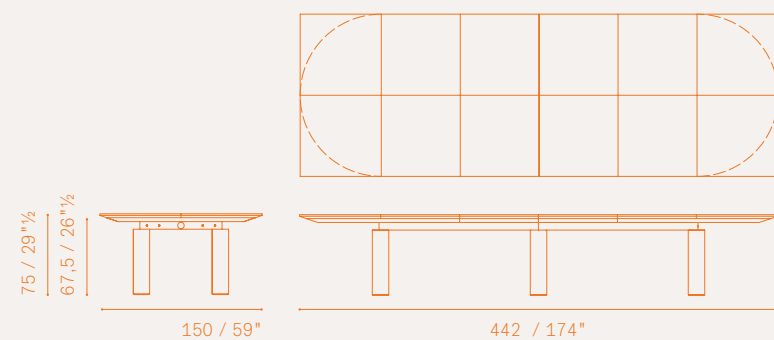

Please note:  
this catalogue shows only some technical drawings, in order  
to know all the availabilities please refer to the current price list.

C.E.O. Cube Meeting Table 515×150cm Oval / Rectangular / with President Area — Pelle Frau® SC leather

Hardware Versions Meeting Table

5175621 Rectangular  
5175636 Oval

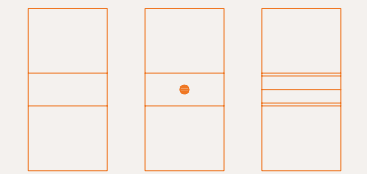
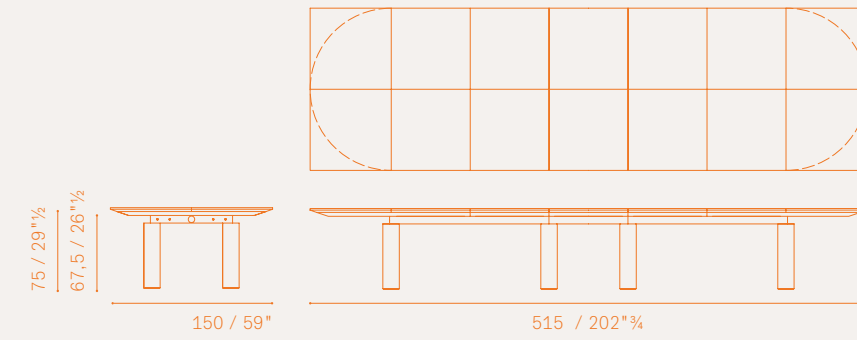

C.E.O. Cube Meeting Table 588×150cm Oval / Rectangular / with President Area — Pelle Frau® SC leather

Hardware Versions Meeting Table

5175621 Rectangular  
5175636 Oval

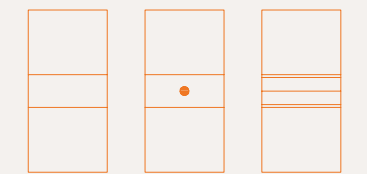
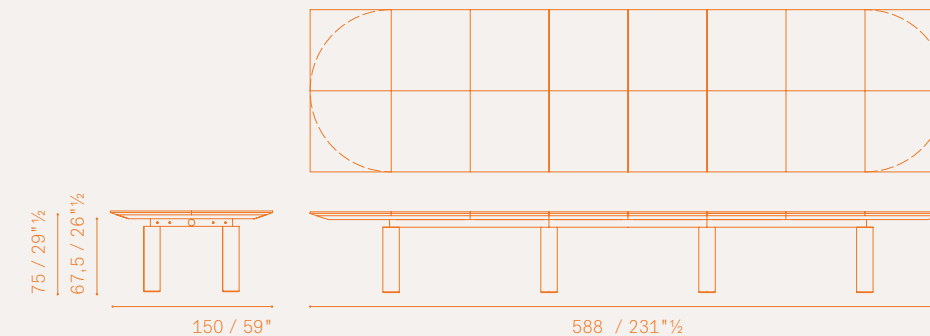

C.E.O. Cube Meeting Table 661×150cm Oval / Rectangular / with President Area — Pelle Frau® SC leather

Hardware Versions Meeting Table

5175622 Rectangular  
5175637 Oval

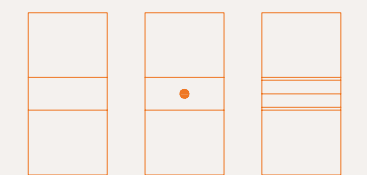
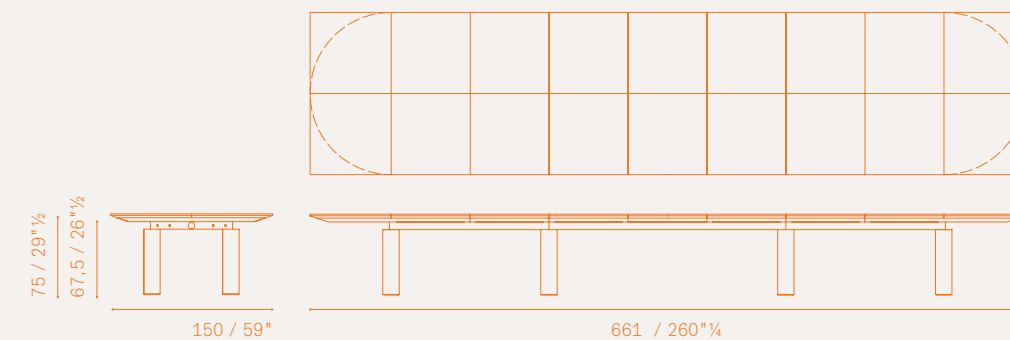

# C.E.O. Cube

C.E.O. Cube Meeting Table 734×150cm Oval / Rectangular / with President Area — Pelle Frau® SC leather

5175621 Rectangular  
5175636 Oval

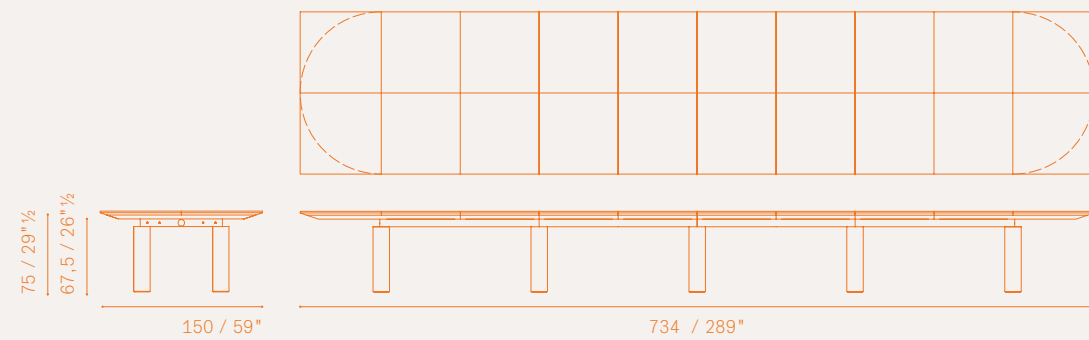

C.E.O. Cube Low Cabinet — Pelle Frau® SC leather / Small Cabinet  
— Pelle Frau® SC leather

5175682

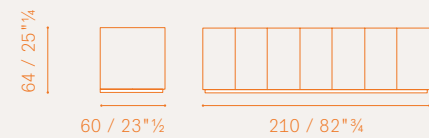

5175680

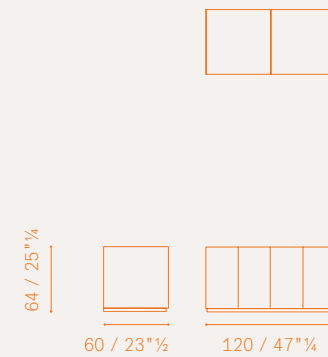

5175761

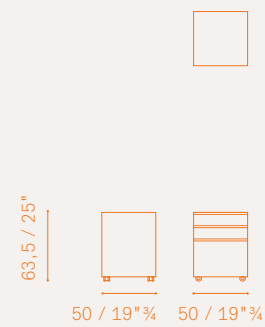

Please note:

this catalogue shows only some technical drawings, in order to know all the availabilities please refer to the current price list.



# Claudio Silvestrin

# H\_0



## CLAUDIO SILVESTRIN

Nato nel 1954, Claudio Silvestrin ha studiato a Milano e ha completato la sua formazione a Londra dove oggi lavora. Si occupa di interni domestici e commerciali, di musei e spazi espositivi e di design per brand prestigiosi. Il suo design austero, ma non estremo, contemporaneo e tuttavia senza tempo, persegue un minimalismo che non è uno stile, ma un modo di essere, una reazione forte al rumore e al disordine. Il suo lavoro è senza tempo, nobile e piacevole, intellettuale e sensibile, solare e tranquillo, attento alla perfezione di ogni dettaglio.

## CONCEPT

Natura e design. Nuovi equilibri materiali e un lusso mai ostentato. Incentrato sulla bellezza naturale di materiali della tradizione artigiana più antica, come pelle, pietra, legno e un design attento alle proporzioni armoniche fra le parti. Il programma H\_0 rimanda a una rinnovata attitudine ad avere cura e piacere per la qualità unica di arredi esclusivi.

## CLAUDIO SILVESTRIN

Born in 1954, Claudio Silvestrin studied in Milan and completed his training in London where he now works. He specialises in domestic and commercial interiors, museum and exhibition space interiors and designs for top brands. His designs, austere but not extreme, contemporary and yet timeless, pursue a form of minimalism. This is not really a style, but a modus operandi, a strong reaction to noise and chaos. His work is timeless, noble and pleasant, intellectual and sensitive, bright and calm, attentive to the perfection of every detail.

## CONCEPT

Nature and design. New material balances and a luxury that is never ostentatious. Focused on the natural beauty of the most time-honoured materials of the artisanal tradition, such as leather, stone and wood, and designs that pay close attention to the harmonious proportions of the various elements. The H\_0 programme is a return to taking care and pleasure in the unique quality of exclusive furnishings.

## クラウディオ・シルヴェストリン

1954年生まれ。クラウディオ・シルヴェストリンはミラノで学んだ後、ロンドンで学業を終え、現在もロンドンで仕事をしている。住居や店舗のインテリア、ミュージアムや展示会場のデザイン設計、高級ブランドのためのデザインを手掛ける。装飾を抑えたデザインだが極端では無く、コンテンポラリーでありながらタイムレス。ミニマリズムを様式としてではなく、騒音と無秩序への強い反発を示す生き方として追求している。シルヴェストリンの作品は

タイムレスで気品があり心地良く、知性的で感性豊か、明るくて落ち着きがあり、あらゆるディティールの完成度にこだわっている。

## コンセプト

自然とデザイン。素材の新しいパランス、ひけらかさないラグジュアリー。レザー、石材、ウッドのような、古来の伝統工芸で使われて来た素材のナチュラルな美しさを活かし、デザインにおいては各部分が調和のとれた均衡を保つよう配慮する。H\_0 プログラムは他に類を見ないほど質の高い家具を作るために手間をかけ、質の高さに喜びを見出す姿勢を新たに示す。

## 罗多尔夫・多尔多尼

Claudio Silvestrin 出生于 1954 年，曾就读于米兰，在伦敦完成训练指导课程并工作至今。他致力于家庭及商业室内空间设计、博物馆及展厅室内空间设计，并为众多一线品牌提供设计。他的设计风格质朴严肃，从不剑走偏锋，充满当代精神却又经得起时间考验，追求形式上的极简主义。这并非是一种风格，更像是一种特立独行的行为方式，对嘈杂混沌的强烈反应。他的作品是那样经典，高贵、令人愉悦；充满着睿智，明快，有一种让人平静的力量；对每一处细节都追求尽善尽美。

## 理念

自然与设计并存。新材料之间的相互平衡，营造出奢华却不浮夸的感觉。重点突出手工艺传统中那些历经时间洗刷的材质的自然之美，比如皮革，石头或木材，宣扬对于不同元素的应用比例拿捏得恰如其分的设计之美。H\_0 项目是一种回归，对于与众不同的家具给予独一无二的品质关怀与用心。





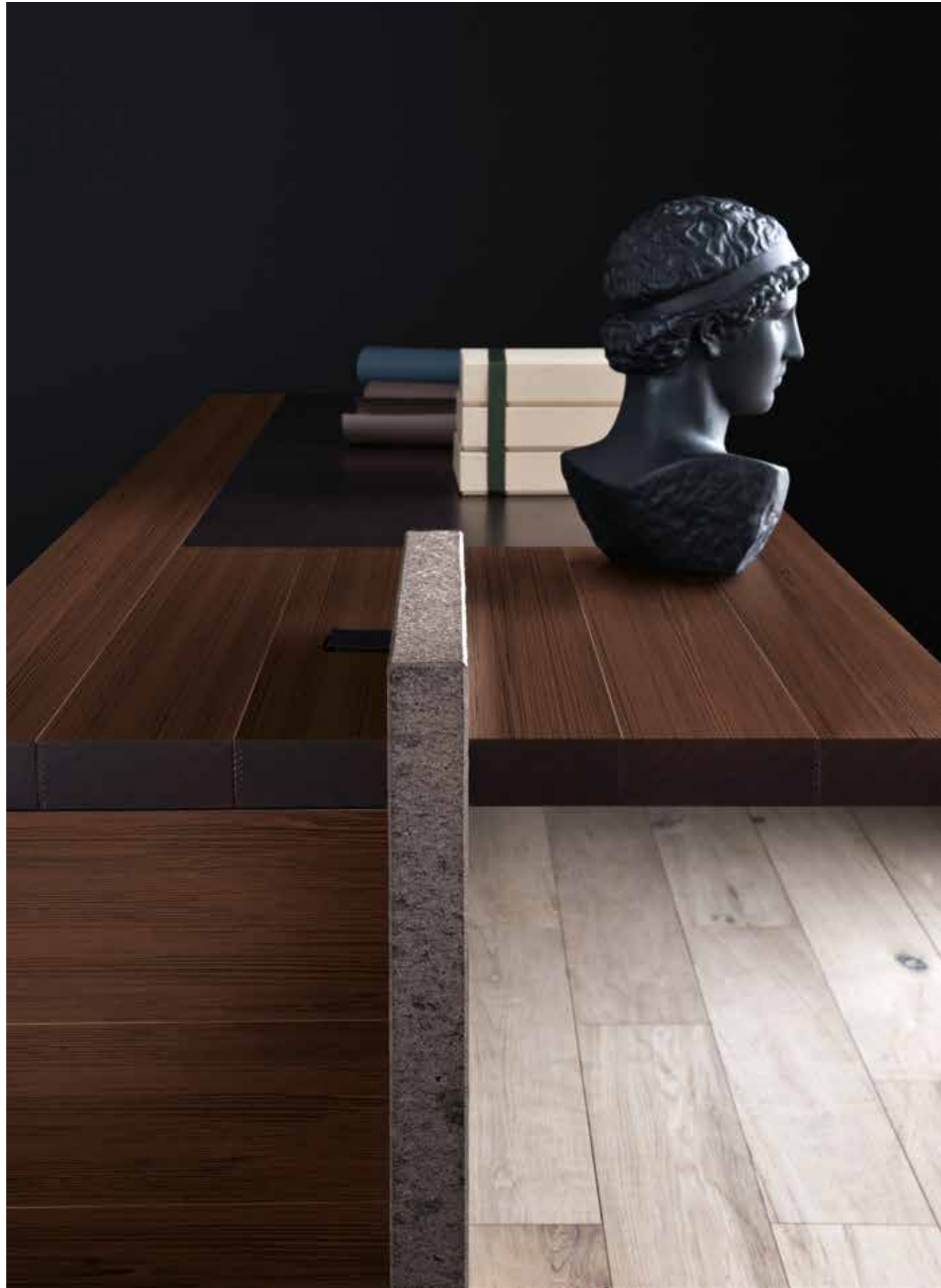

↑ H\_0 President Desk — Valcamonica Porphyry column ʘ Drawer Unit

Collezioni Ufficio — H\_0

Office Collections — H\_0

エグゼクティブシステムズ — H\_0

賢 権様 権 任 折 — H\_0

Il cuoio o la pelle, tre diverse tipologie di pietra, il legno, in essenza e laccato lucido. Scrivanie, tavoli riunione e mobili contenitori.

#### PELLE FRAU® COLORSPHERE® E CUOIO SADDLE

La tattilità del cuoio, lavorato artigianalmente, si esprime nel pattern a quadri, "square", ben visibile sui piani di tavoli e scrivanie e sulle facciate verticali di cabinet, consolle e libreria. Due i colori disponibili, Tortora e Caffè, anche nella versione "liscia". La matericità della Pelle Frau® SC si manifesta invece nella versione "Lac" delle desk come rivestimento per sottomano e gamba di sostegno. Anche il cabinet può essere in pelle.

#### PORFIDO

La bellezza naturale del porfido si riconosce nelle colonne di sostegno di scrivanie e tavoli. Due le pietre utilizzate: Porfido Valcamonica, con colorazioni marrone/viola e Porfido Bianco, con colorazioni bianco/beige.

Leather and saddle leather, three different types of stone, gloss lacquer or veneer woods. Desks, meeting tables and furniture units.

#### PELLE FRAU® COLORSPHERE® LEATHER AND CUOIO SADDLE LEATHER

The tactility of the handcrafted hide is evident in the clearly visible "square" patterns on the table and desk surfaces and on the vertical faces of the cabinets, consoles and bookcases. Available in two colours - Tortora and Caffè - also in the "smooth" version. Meanwhile, the material feel of the Pelle Frau® SC leather comes to the fore in the "Lac" versions of the desks as a cover for the desk pad and supporting leg. The cabinet can also come in leather.

#### PORPHYRY

The natural beauty of porphyry can be seen in the supporting columns of the desks and tables. Two stones are used: Valcamonica Porphyry, with its brown/purple colouring, and White Porphyry, with its white/beige colouring.

皮革、三種の異なる石材、ウッドは木目仕上げと光沢ラッカー仕上げ。デスク、会議用テーブル、キャビネット類。

#### PELLE FRAU® COLORSPHERE® ペレフラウ® のカラーシステム

##### CUOIO SADDLE クオイオ・サドル

テーブルやデスクの天板、キャビネット、コンソール、本棚の正面にはっきりと見て取れる“スクエア”のチェッカー・パターンを通して職人の技で鞣したレザーならではの風合いが表現力を発揮する。色はトルトラとカフェの2色展開、“スムーズ”タイプのレザーでも同じ2色。Pelle Frau® ペレ・フラウ®SCの素材感ではデスクの“Lac”ラックのタイプのデスクパッドや脚部のレザー張りでも活かされる。キャビネットもレザー張りが可能。

##### 斑岩、トラバーチン、スレート

デスクやテーブルの支柱には斑岩のナチュラルな美しさが活かされる。使用される石材は2種類: Profido Valcamonica イタリアのカモニカ渓谷産の茶／紫色の斑岩および Profido Bianco 白／ベージュ色の白斑岩。“Lac”ラックのデスクでは Travertino bianco ホワイト・トラバーチンもしくは Ardesia スレートが支柱に使われ、石材のエレガンス際立つ。

皮革以及超厚皮革，3 种不同质地的石材，贴面为亮光烤漆或木饰面。有桌子，办公桌及其他家具单元组成。

#### 从色彩系统中挑选的 PELLE FRAU® 皮革以及 CUOIO SADDLE 超厚皮革

无论是桌面或茶几台面 上显而易见的方形图案内，还是在橱柜，控制台或书柜的垂直面上，随时可以感受到手工打磨的原皮触感。有两种颜色 - 驼色或咖啡色 - 同样也有“光滑”的皮革套面款式可供挑选。于此同时，对于 Pelle Frau® SC 皮革的触感来自“Lac”款式办公桌的前端，用该皮革包裹桌面的办公区域及桌腿。储物单元也同样软包皮皮革。

#### 斑岩

斑岩的自然之美从办公桌与茶几的支撑立柱上可见一斑。这其中，运用了两种斑岩：棕色或紫色的为火山斑岩，而呈现出白色或米色的部分则运用了白斑岩。





# H\_0 President Desk

La versione scura delle desk H\_0, nelle foto, presenta la gamba e il sottomano in Cuoio Saddle "square" color Caffè, il piano e la cassetiera in noce Canaletto e la colonna in Porfido Valcamonica.

In the photos the dark version of the H\_0 desks, has Caffè-coloured "square" Cuoio Saddle leather leg and desk pad, top and chest of drawers in Canaletto walnut and a Valcamonica Porphyry column.

H\_0 デスクのダーク・カラーのタイプ、写真の製品は脚部とデスクパッドが Cuoio Saddle クオイオ・サドルの“スクエア”で色は Caffè カフェ、天板と引き出しはウォールナットルーロプレート、支柱は Profido Valcamonica カモニカ渓谷産斑岩。

图片为深色款的H\_0 桌，咖啡色方形桌腿包裹 Cuoio Saddle 超厚皮革，桌面的工作区，顶面，以及斗柜都采用了胡桃木以及火山斑岩支柱。

Nelle versioni "square" il rivestimento base è realizzato con un motivo "tono su tono" a scacchi di 16×16 cm. Il pannello di cortesia, optional, è sempre in Cuoio Saddle liscio abbinato.

In the "square" versions, the basic cover includes a 16×16 cm "ton sur ton" chessboard motif. The optional modesty panel is in matching Cuoio Saddle leather, always in the smooth variant.

“スクエア”のタイプでは、ベースは“トーン・オン・トーン” 16x16 cm のチェッカー・モチーフでレザーが張られており、使用者の脚を隠すためのレザー張りのパネルはオプションで、スムーズの Cuoio Saddle クオイオ・サドルで色をコーディネート。

在方形的款式中，16×16 cm 见方的跳色棋盘格构成了最基本的图案。可另外添置的私密活动挡板为了搭配 Cuoio Saddle 超厚皮革，总是采用光滑的纹理。



Il cabinet H\_0 è disponibile in Pelle Frau® del ColorSphere®, o in cuoio Saddle, sia liscio che "square". Nelle foto al lato è presentato nella versione in Pelle Frau® SC 26 Topo e in Cuoio Saddle "square" Caffè, sempre in abbinamento al legno noce Canaletto. Il cabinet è attrezzato con quattro cassetti e quattro vani dotati di anta e attrezzati internamente con mensole.

The H\_0 cabinet is available in Pelle Frau® ColorSphere®, or both in smooth and "square" Cuoio Saddle leather. The photos show the Pelle Frau® SC 26 Topo version and the dark one in Caffè-coloured "square" Cuoio Saddle leather, both matched with Canaletto walnut wood. The cabinet comes with four drawers and four compartments with doors, and has shelves inside.

H\_0 のキャビネットは Lac ラックのデスクとコーディネートして ColorSphere® カラー・システムの Pelle Frau® ベッレ・フラウ® でレザー張り、あるいは、Cuoio Saddle クオイオ・サドルのスムーズ、もしくは、“スクエア”でも可能。横の写真では、Pelle Frau® ベッレ・フラウ® SC 26 Topo トーボ、および Cuoio Saddle クオイオ・サドルの“スクエア”の Caffè カフェ色、組合わせるのは常に noce Canaletto. ルーロプレートの木目仕上げ。キャビネットには引き出しが 4 つと扉付のコンパートメントが 4 つ付いており、その内部には棚がついている。

从色彩系统中精选光滑或“方形”图案的 Pelle Frau® 皮革或 Cuoio Saddle 超厚皮革软包可供挑选。图示为深色款储物柜。咖啡色“方形”图案 Cuoio Saddle 超厚皮革搭配柏图木。储物柜包含 4 个抽屉以及 4 个带柜门的单元格，内部自带搁板。

# H\_0 Cabinet



# H\_0 Executive Desk

La versione chiara delle desk H\_0 prevede il sottomano e la gamba in Cuoio Saddle color Tortora, liscio o "square", il piano e la cassettera in Rovere Tortora e la colonna in Porfido bianco.

The light version of the H\_0 desks have desk pad and leg in smooth or "square" Tortora-coloured Cuoio Saddle leather top and drawer unit in Ash-Tinted Oak and column in White Porphyry.

H\_0 デスクのライト・カラーのタイプでは、Tortora ダヴ・グレー色のスムーズもしくは"スクエア"の Cuoio Saddle クオイオ・サドルをデスクパッドと脚部に使う。天板と引き出しは Rovere Tortora ダヴグレー・オーク、支柱は Profido Bianco 白斑岩。

H\_0 办公桌的浅色款拥有光滑或带有方形图案的驼色 Cuoio Saddle 超厚皮革包裹的工作区域或桌腿，顶面以及抽屉单元采用灰色橡木打造，白色斑岩支柱。

Il pannello di cortesia, optional, è sempre in cuoio liscio abbinato.

The optional modesty panel is always in matching smooth saddle leather version.

使用者の脚を隠すためのパネルはオプションで、コーディネート・カラーのスムーズ・レザー張り。

可另外添置的私密活动挡板总是能搭配光滑的 Saddle 超厚皮革。



# H\_0

**H\_0 President Desk** — Saddle or Saddle Square leather  
5355707

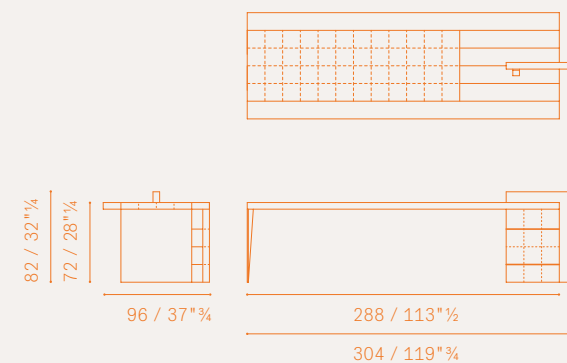

**H\_0 President Desk** — with modesty panel — Saddle or Saddle Square leather  
5355707

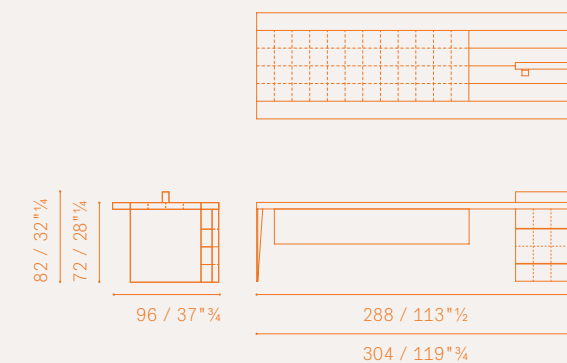

**H\_0 Executive Desk** — Saddle or Saddle Square leather  
5355706

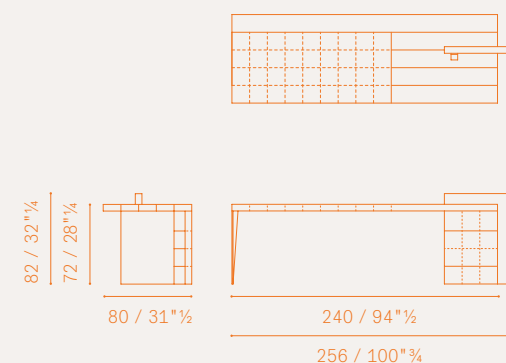

**H\_0 Executive Desk** — with modesty panel — Saddle or Saddle Square leather  
5355706

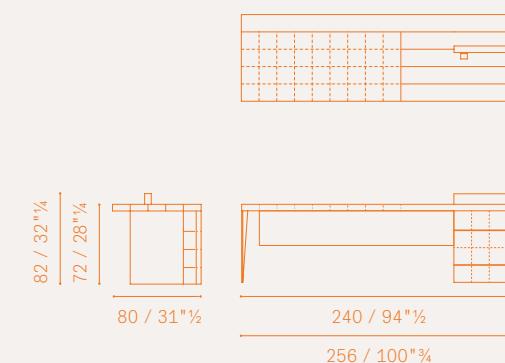

**H\_0 Cabinet** — Saddle or Saddle Square leather  
5355781

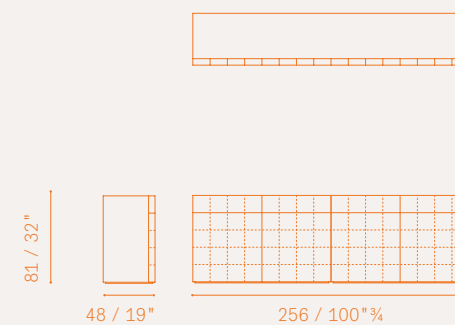

**H\_0 Cabinet** — Pelle Frau® SC leather  
5355781

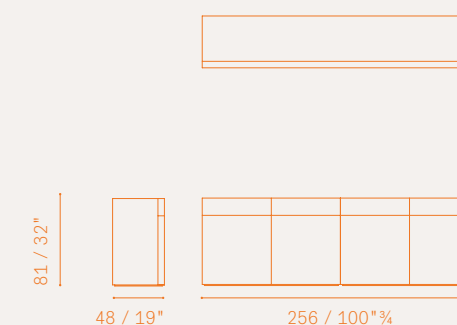

## Lella and Massimo Vignelli

# Mesa Due Meeting Table



### LELLA E MASSIMO VIGNELLI

Lella Vignelli è nata a Udine, si è laureata in architettura a Venezia. Massimo Vignelli è nato a Milano nel 1931, ha studiato architettura a Milano e a Venezia. Svolgono attività nel campo della grafica, programmi d'immagini coordinate per l'industria, segnaletica, disegno industriale; progettano mobili, interni e allestimenti. Originariamente a Milano e dal 1965 a New York, lo studio collabora con alcune fra le più importanti industrie e istituzioni americane e europee.

### CONCEPT

Il concetto di tavolo nella sua essenzialità scultorea. Mesa. Progetto di Lella & Massimo Vignelli nato nel 1985. Una matrice fertile di sviluppi, da cui Poltrona Frau trae una collezione sempre più ampia e trasversale. Mesa Due Meeting Table è la nuova versione per gli spazi di lavoro. Sofisticata nei materiali, tecnologica nelle prestazioni, flessibile nel design. Un sistema di tavoli riunione rettangolari o ovali. Il piano si compone di più pannelli ed è quindi espandibile in diverse lunghezze. A seconda delle dimensioni si moltiplicano anche i sostegni.

### LELLA AND MASSIMO VIGNELLI

Lella Vignelli レッラ・ヴィニエリはウディネで生まれ、ヴェネツィアで建築学の学位を取得。Massimo Vignelli マッシモ・ヴィニエリ (1931-2014) はミラノで生まれ、ミラノとヴェネツィアで建築を学ぶ。Vignelliヴィニエリ・アソシエイツ・スタジオをミラ

### LELLA AND MASSIMO VIGNELLI

Lella Vignelli レッラ・ヴィニエリはウディネで生まれ、ヴェネツィアで建築学の学位を取得。Massimo Vignelli マッシモ・ヴィニエリ (1931-2014) はミラノで生まれ、ミラノとヴェネツィアで建築を学ぶ。Vignelliヴィニエリ・アソシエイツ・スタジオをミラ

### CONCEPT

「彫刻の本質」がコンセプトのテーブル。Mesa。1985年生まれのレッラ&マッシモ・ヴィニエリのプロジェクト。独創性豊かな開発のマトリックスを起点にPotrona Frauは一層多彩で幅広いコレクションを創作し続けています。Mesa Due Meeting Tableは仕事場のための新しいバージョンです。洗練された素材、高度な技術的性能、フレキシブルなデザイン。長方形または楕円形のミーティングテーブルシステム。テーブルトップは複数のパネルで構成されていますので、様々な長さに広げることが出来ます。テーブルトップの面積に応じて支脚の本数も倍になります。

### LELLA AND MASSIMO VIGNELLI

Lella Vignelli 出生于意大利乌迪内，毕业于威尼斯建筑学院。Massimo Vignelli (1931-2014) 出生于米兰，并在米兰和威尼斯深造建筑学。一开始活跃于米兰，1965年起把工作重心转移到纽约，Vignelli 联合设计工作室与各个重量级的欧美公司都有着密切的合作关系。Lella 和 Massimo Vignelli 的工作范畴包括 图形设计、公司形象设计、标志及工业设计；同时他们也涉足配饰、家具、室内与展会装置设计。

### 理念

以雕塑般的精简展示桌子的概念。Mesa。Lella & Massimo Vignelli 的设计，诞生于1985年。这是一个充满发展能力的基质，Potrona Frau从中汲取日益丰富多样的产品系列。Mesa Due Meeting Table 是适合工作空间的新版本。复杂的材料，高科技性能，灵活的设计。长方形或椭圆形会议桌系统。桌面由多个板块构成，因此可以扩展为不同长度。根据尺寸不同，也可以增添支撑结构。



La collezione comprende anche nuove varianti per il tavolo tondo Mesa Due. Perfetto nei due diametri 120 e 150 come elegante tavolo per piccole riunioni. La base in acciaio, rivestita in Pelle Frau® del ColorSphere® o in Cuoio Saddle Extra, è ora attrezzabile con colonnina elettrica a scomparsa. Il piano in frassino è disponibile nelle finiture tinto moka o tinto wengè. Il sostegno è disponibile anche in pietra serena, come nel progetto originale di Mesa.

The collection also includes new variants of the Mesa Due round table. Both the 120 and 150 diameters are perfect as an elegant table for small meetings. The steel base, covered in Pelle Frau® leather from the ColorSphere® or in Cuoio Saddle Extra Leather, can now be fitted with a hidden cable column. The ash top is available in a moka- or wenge-stained finish. A base is also available in pietra serena, in line with the original Mesa project.

コレクションにはラウンドテーブル Mesa Due の新しいバージョンも含まれています。直径 120 及び 150 のエレガントなテーブルはどちらも小規模なミーティングに最適です。脚ベースは ColorSphere® の Pelle Frau®、または Cuoio Saddle Extra でコーティングされたスチール製で、隠れた電動式コラムを整備出来るようになりました。トネリコ材のテーブルトップには Moka 染色仕上げと Wengè 染色仕上げの2タイプがあります。支脚が Mesa の最初のプロジェクトの素材であったセレーナ石のバージョンもあります。

本产品系列同时也包括 Mesa Due 圆桌的新版本。直径分别为 120 和 150，完美适合作典雅的小型会议桌。钢制底座，覆盖 Pelle Frau® ColorSphere® 软皮或 Cuoio Saddle Extra 真皮，该版本也可配备电力伸缩柱。白蜡实木桌面也可使用摩卡色或鸡翅木色。支脚也可使用塞茵那石，如同 Mesa 的原始设计。





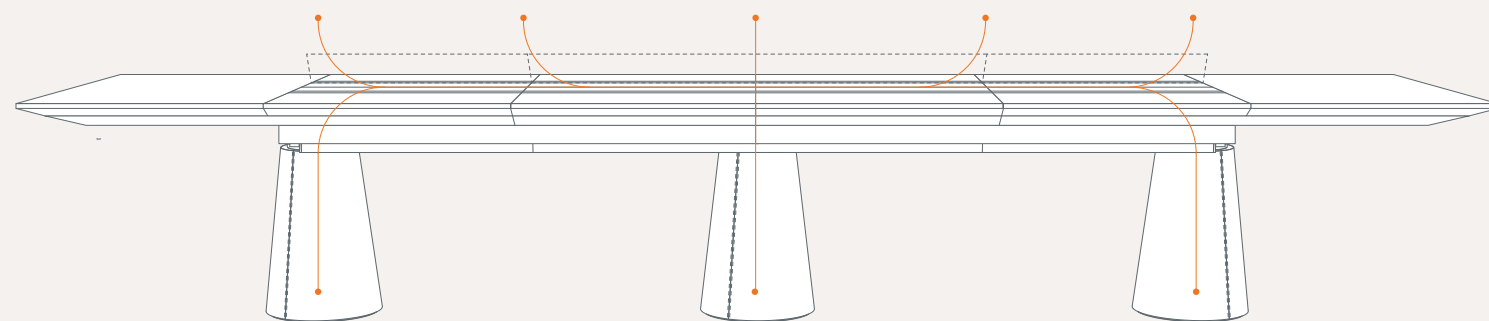
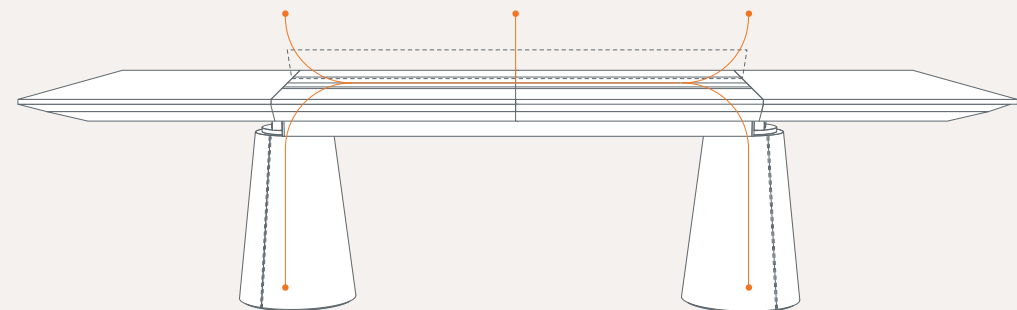

Tutti i tavoli sono integrabili con sistema passacavi e eventuali pannelli centrali a sportello, per accedere agevolmente alle componenti elettriche. Il piano con doppia pannellatura di fibra di legno a media densità è interamente rivestito in Pelle Frau® del ColorSphere®. Il telaio portante sotto piano è in ferro verniciato nero. La colonna di sostegno in acciaio, stabilizzata da un sistema di contrappesi, è rivestita in Pelle Frau® del ColorSphere® con cuciture tono su tono o in Cuoio Saddle Extra con cuciture a contrasto.

All the tables can be integrated with cable-management systems and lift-up central panels for easy access to the electrical parts. The top with double MDF panelling is entirely covered in Pelle Frau® leather from the ColorSphere®. The frame supporting the top is in black-painted iron. The steel support column, stabilised by a counterweight system is covered in Pelle Frau® leather from the ColorSphere® with tone-on-tone stitching or in Cuoio Saddle Extra Leather with contrasting stitching

全てのテーブルは電子部品に快適に接続できるようケーブル通しシステムと、(場合に応じて)中央に開閉可能なパネルを組み込むことができます。中密度ウッドファイバー(MDF)パネルを二重に重ねたテーブルトップはColorSphere®のPelle Frau®でコーティングされています。テーブルトップ下を支えるフレームはブラック塗装された鉄製です。カウンターウェイトシステムによって安定した支柱は同系色または反対色のステッチが入ったColorSphere®のPelle Frau®でコーティングされています。

所有桌子都配有走线系统,并在需要的情况下设有中部开合式面板,以方便连接电器部件。双层中密度木质纤维桌板完全由Pelle Frau® ColorSphere®软皮包覆。桌面下部采用黑色漆面铁制支撑框架。支撑立柱为钢制,利用配重系统加以稳定,并采用Pelle Frau® ColorSphere®皮革包覆,饰以同色调缝线;或为Cuoio Saddle Extra革,饰以对比色缝线。

# Mesa Due Meeting Table

Mesa Due Meeting Table Round ø 150 wood

5590633

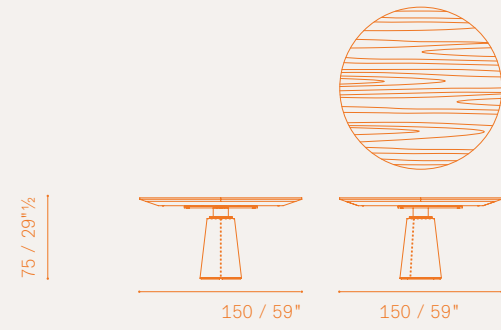

Mesa Due Meeting Table Round ø 120 wood

5590631

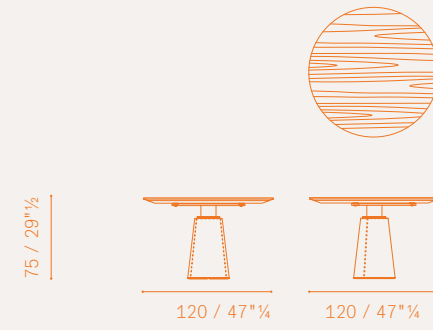

Mesa Due Meeting Table Round ø 150 leather

5590637

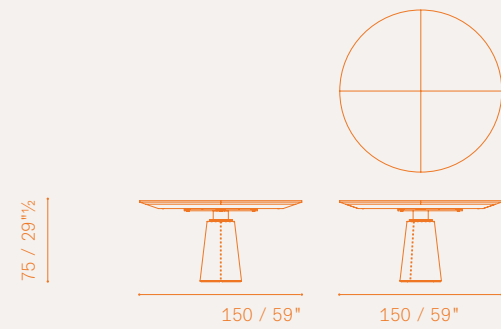

Mesa Due Meeting Table Round ø 120 leather

5590635

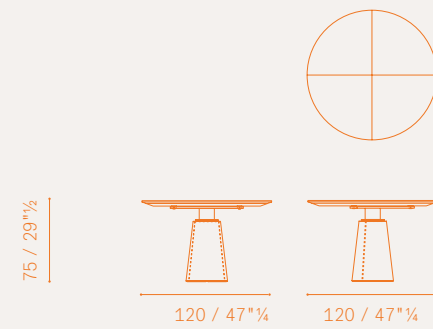

## Please note:

this catalogue shows only some technical drawings, in order to know all the availabilities please refer to the current price list.

Mesa Due Meeting Table 296×150cm Oval / Rectangular / with President Area

5590621 Rectangular  
5590641 Oval

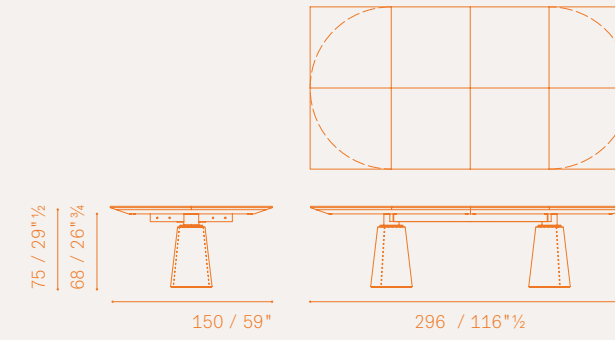

Hardware Versions Meeting Table

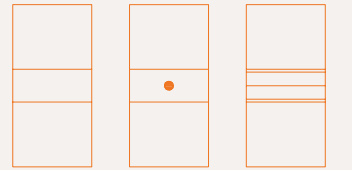

Mesa Due Meeting Table 369×150cm Oval / Rectangular / with President Area

5590622 Rectangular  
5590642 Oval

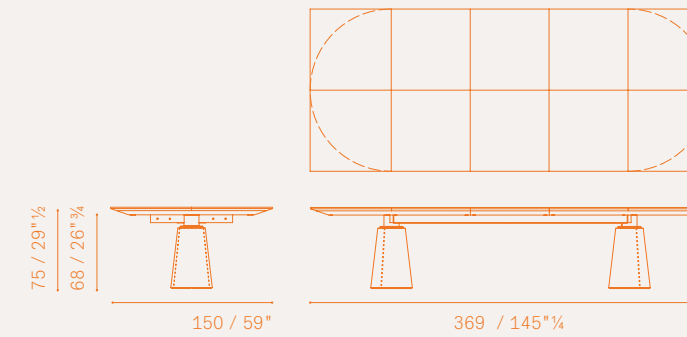

Hardware Versions Meeting Table

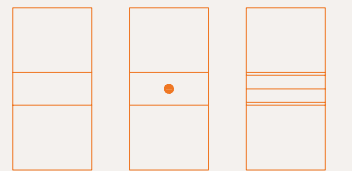

Mesa Due Meeting Table 442×150cm Oval / Rectangular / with President Area

5590623 Rectangular  
5590643 Oval

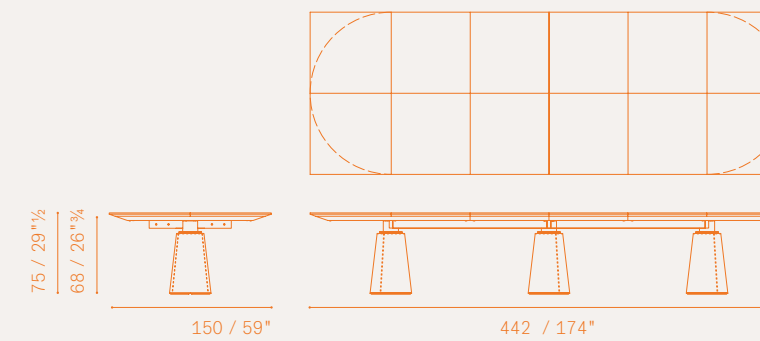

Hardware Versions Meeting Table

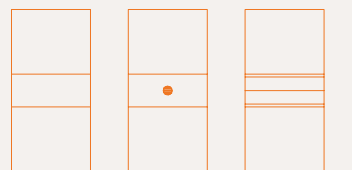

# Mesa Due Meeting Table

**Please note:**  
this catalogue shows only some technical drawings, in order to know all the availabilities please refer to the current price list.

## Mesa Due Meeting Table 515×150cm Oval / Rectangular / with President Area

5590624 Rectangular  
5590644 Oval

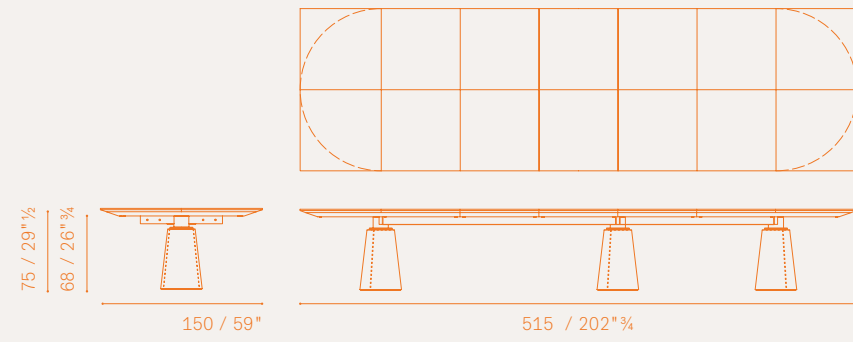

## Hardware Versions Meeting Table

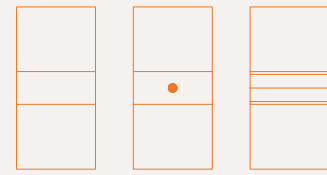

## Mesa Due Meeting Table 734×150cm Oval / Rectangular / with President Area

5590627 Rectangular  
5590647 Oval

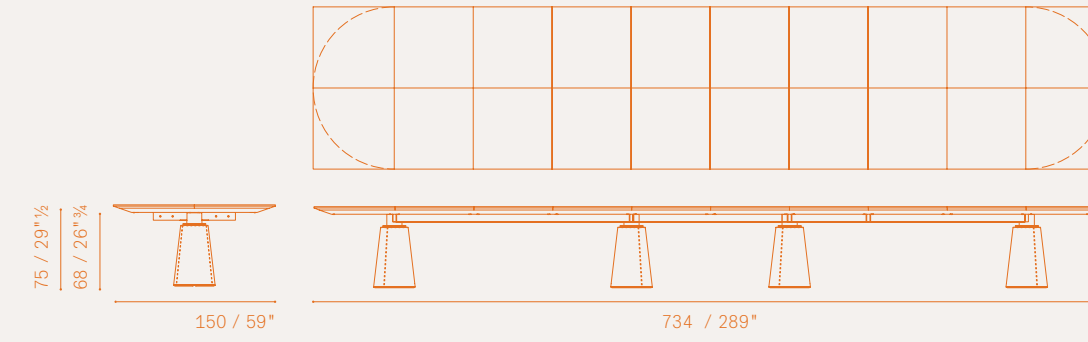

## Hardware Versions Meeting Table

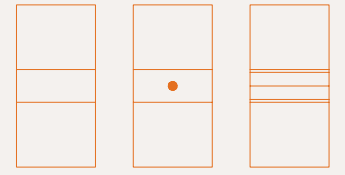

## Mesa Due Meeting Table 588×150cm Oval / Rectangular / with President Area

5590625 Rectangular  
5590645 Oval

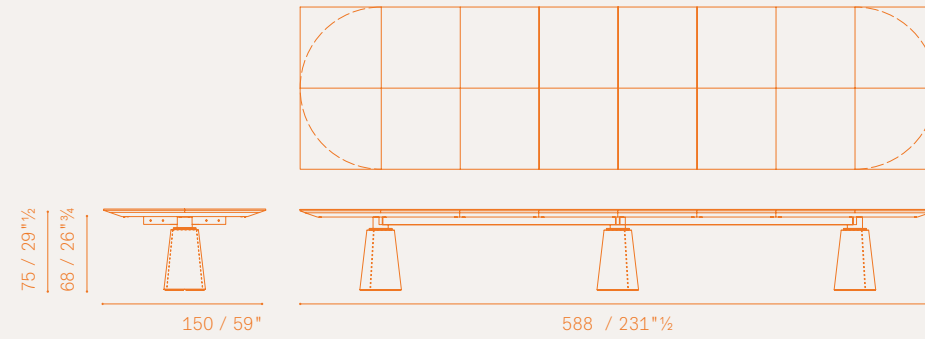

## Hardware Versions Meeting Table

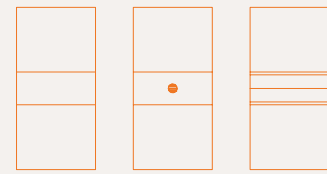

## Mesa Due Meeting Table 661×150cm Oval / Rectangular / with President Area

5590626 Rectangular  
5590646 Oval

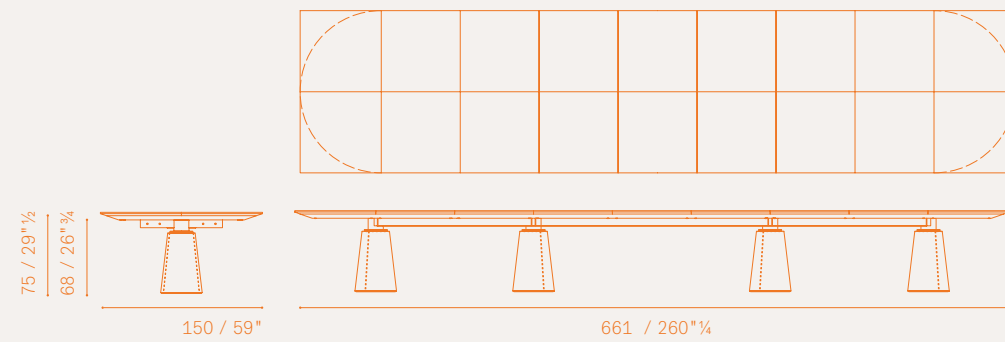

## Hardware Versions Meeting Table

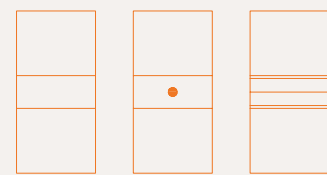

## Mesa Due Meeting Table — Finishings

Column base  
— Saddle Extra leather  
— ColorSphere® leather

Top  
— Ash in a wengé stain  
— Ash in a Moka stain  
— ColorSphere® leather

## Trust

Poltrona Frau presenta il sistema executive office Trust. Scrivanie, pareti autoportanti e contenitori d'archivio disegnati da Lievore, Altherr, Park, danno vita a un concetto totalmente nuovo di ufficio. Trust è una collezione nata da una profonda ricerca sull'evoluzione del lavoro contemporaneo. Oggi infatti i ruoli sono meno rigidi e gerarchici, a favore di una maggiore orizzontalità delle relazioni. La tecnologia rende sempre più sottili i confini tra casa e ufficio che si ridefiniscono a vicenda, in una fluidità di scenari dove diventa necessario poter alternare oasi di concentrazione individuale, zone di relax e aree di condivisione e incontro.

In quest'ottica, tutti gli elementi Trust sono liberamente combinabili fra loro, adattandosi allo stile di lavoro di chi li abita. Volumi e costruzioni sono aerei, leggeri e insieme materici. Le forme sono morbide, organiche, smussate. Tutto è realizzato in pelle, cuoio e legno, rielaborati a misura di ufficio. L'assenza totale di cuciture, eseguita grazie a lavorazioni magistrali, ha un effetto high tech e contemporaneamente artigianale.

Poltrona Frau presents the Trust executive office system. Desks, self-supporting walls and storage units designed by Lievore, Altherr and Park for a completely new office concept. Trust is a collection that stems from in-depth research into the evolution of contemporary work. Nowadays, in fact, roles are less rigid and hierarchical, with greater emphasis placed on horizontal relationships. Technology increasingly narrows the confines between the home and the office which redefine each other in turn in fluid scenarios where it is necessary to alternate oases of individual concentration with areas of relaxation and places for meeting and exchange.

In this context all Trust elements can be freely combined together, adapting to the working style of the user. Volumes and constructions are airy, light and textural. The forms are soft, organic, tapered. Everything is made from leather, saddle-leather and wood, revisited to suit the office space. The total absence of stitching, thanks to the masterful processing, gives it both a high-tech and artisan feel.

Poltrona Frau が管理オフィス用システム「Trust」を提供いたします。リエボレ、アルテール、パークがデザインしたデスク、シェル構造壁、アーカイヴ収納ケースで構成されたこのシステムは、まったく新しいオフィスの概念を誕生させました。「Trust」は現代における仕事の進化を精査した結果として生み出されたコレクションです。現在の職場

では以前のような固定化した上下関係が薄れつつあり、代わって横の関係が強化されてきています。技術の進歩により、家庭と職場の境界が薄れ、家庭と職場の役割も変わってきました。こうした流動の渦中では、仕事の場が、個人にとって集中できるオアシス、リラックスできる空間、共有と出会いの場になる必要があります。

この観点から見ると、「Trust」の構成要素は、そこに暮らす人の仕事のスタイルに合わせて、すべてを自由に組み合わせることが可能です。サイズも構造もエアーリーで軽やかであると同時に材質を活かしたものになっています。フォームはやわらかく有機的で、角は丸くなっています。すべてがレザー、なめし革、木で作られて、オフィスの大きさに合わせて調整されます。優れた細工技術により、ステッチが皆無であるところから、ハイテクな印象が生れ、現代のアルチザンのわざが感じられます。

Poltrona Frau推出Trust总裁办公室系统。写字台、独立墙、档案柜，由Lievore、Altherr、Park设计，带来全新办公室概念。Trust系列源自当代工作发展的深入探索。事实上，如今的工作角色不再僵硬，层级关系更弱，平级关系更多。技术令家庭和办公室之间的界限更模糊，两者之间互相转换，在场景流动性中，必须能够在个人专注绿洲、放松区域以及分享和会面区域进行更替。从这个角度出发，Trust的所有元素均可互相之间自由组合，适合所在工作风格。轮廓与构造空灵、轻盈、兼具材质感。外形柔软、有机、角度圆滑。全部采用皮革、鞣制皮革、木材，为办公室量身制作。凭借精湛加工工艺，完全没有缝线，带来高科技和当代手工艺效果。



Iconic Desk  
228×137



Iconic Desk  
214×107



Iconic Desk  
183X97 Cm



Regular Desk  
214×107



Regular Desk  
183×92



Small Desk  
145×68

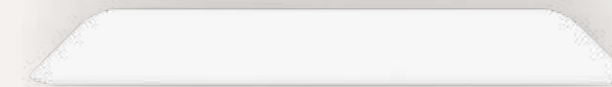
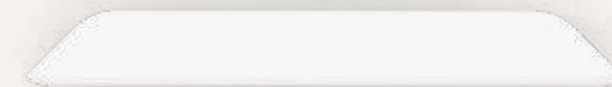
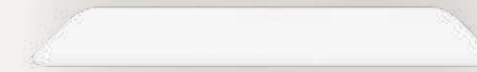
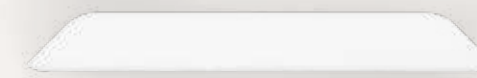

Screen



Cabinet  
Drawer Unit

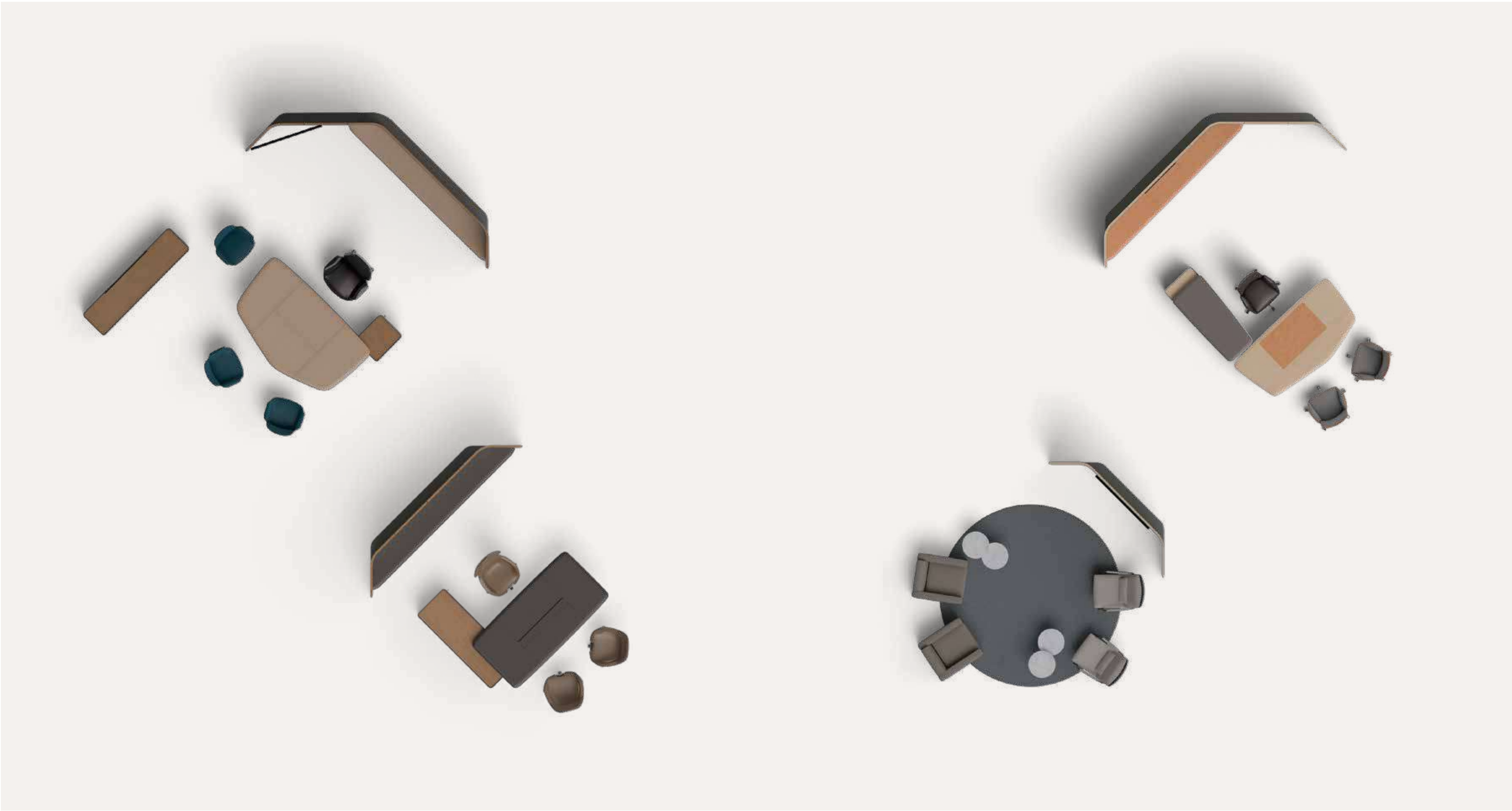











Rivestimenti e materiali, pelle, cuoio e legno, sono il risultato dell'indagine attenta su texture e prestazioni. Poltrona Frau, forte del know-how nella lavorazione di pelle e cuoio, mette a punto Cuoio Saddle Executive, resistente, sottile e plasmabile attorno alle linee arrotondate che connotano Trust. Innovativo anche il legno Techno-Wood, caratterizzato dall'omogeneità delle superfici che rende facilmente reintegrabili ed espandibili nel tempo i diversi moduli. Le due finiture disponibili valorizzano le geometrie sottili e leggere dei top. Techno-Wood con working pad in cuoio o pelle o, in alternativa, il piano interamente avvolto in cuoio o in pelle. L'assenza totale di cuciture, eseguita grazie a lavorazioni magistrali, ha un effetto high tech e contemporaneamente artigianale. Cuoio/pelle o Techno-Wood anche per le gambe. Pelle Frau® SC disponibile in tutti i colori a catalogo.

#### TECHNO-WOOD (TW)

Techno-Wood è una serie di nuovi legni con prestazioni tecniche studiate per gli spazi di lavoro. L'uniformità delle venature e del colore permette di reintegrare nel tempo i diversi complementi, mantenendo l'effetto omogeneo delle superfici e garantendo l'assenza delle tipiche difformità del legno.

#### SADDLE EXECUTIVE

Con una palette di 3 colori ottenuti con tintura passante, offre un'elevata resistenza.

The upholstery and materials, leather, saddle-leather and wood, are the result of in-depth research into textures and performances. Using its leather and saddle-leather processing know-how Poltrona Frau has developed Cuoio Saddle Executive, tough, thin and pliable around the rounded lines typical of Trust. Techno-Wood is also innovative and stands out for the uniformity of its surfaces which make it easy to integrate and expand the various modules over time. The two possible finishes showcase the slender and light geometries of the tops. Techno-Wood with saddle-leather or leather working pad or, alternatively, with the desktop completely upholstered in saddle-leather or leather. The total absence of stitching, thanks to the masterful workmanship, gives it both a high-tech and artisan feel. Saddle-leather/leather or Techno-Wood also for the legs. Pelle Frau® SC leather available in all of the colours in the catalogue.

#### TECHNO-WOOD (TW)

Techno-Wood is a series of new woods with technical qualities designed specifically for the workspace. The uniformity of the veins and the colour makes it possible to integrate the various accessories over time while ensuring the continuity of the surfaces and the absence of typical wood deformities.

#### SADDLE EXECUTIVE

With a palette of 3 colours obtained through drum dyeing, it is highly resistant.

上張りと素材(レザー、皮革、木)は、テクスチャーと性能のきびしい追究から生まれました。Poltrona Frauが誇るレザー／皮革細工のノウハウによって、Trustの特徴である丸みを帯びたラインを包み込む頑丈で薄くしなやかなCuoio Saddle Executiveが創り出されたのです。

Techno-Woodと呼ばれるウッド材も革新的な素材です。表面の均質性が特徴で、さまざまなモジュールが次第にしくりとなじんでいきます。仕上げは二種類。いずれもトップの薄く軽やかな形状をいっそう引き立てるもので、皮革またはレザーのワーキングパッドが付いたTechno-Wood、あるいは全体が皮革またはレザーで包まれた天板です。優れたクラフトマンシップによってまったくステッチの見えない出来上がりで、ハイテクであると同時にアルチザンの手わざを感じさせる効果をあげています。

脚部にも皮革／レザーまたはTechno-Woodが使用されています。Pelle Frau® SCは、カタログ所収のカラー全てでご利用できます。

#### Techno-Wood (TW)

Techno-Wood (TW)はワークスペース用に研究された技術力を駆使して作られた新しいウッド材シリーズです。木目とカラーの均一性によってさまざまなパーツが次第にしくりとなじみ、表面の均質的効果を維持して、木という素材につきものの凸凹がありません。

#### SADDLE EXECUTIVE

通し染色による3色のパレットを揃えて、優れた耐久性を発揮します。

饰面及材料：软皮、硬皮和木材，是对质地和性能精心研究的成果。Poltrona Frau凭借在软皮和硬皮加工方面强大的专有知识，将坚韧、纤薄且具有可塑性的 Cuoio Saddle Executive硬皮应用在 Trust特有的圆润线条周边。Techno-Wood木材也具有创新性，其表面均质性的特点 可使不同的模块随时轻松重新组合和扩展。这两种可用表面彰显出台面纤细轻盈的几何造型。Techno-Wood搭配硬皮或软皮工作垫，或者台面整体包覆硬皮或软皮。凭借精湛加工工艺，完全没有缝线，同时呈现出高科技和手工艺效果。支腿也可采用硬皮/软皮或Techno-Wood。Pelle Frau® SC有目录中的所有颜色可选。

#### TECHNO-WOOD (TW)

Techno-Wood是一系列 具有技术性能的新型木材，专为办公空间设计。纹理和颜色具有一致性，从而可随时 将各部件进行重新组合，保持表面的均匀效果， 确保不会出现 木材的典型差异。

#### SADDLE EXECUTIVE

有3种颜色，采用渗透染色工艺， 具有极高的耐用性。

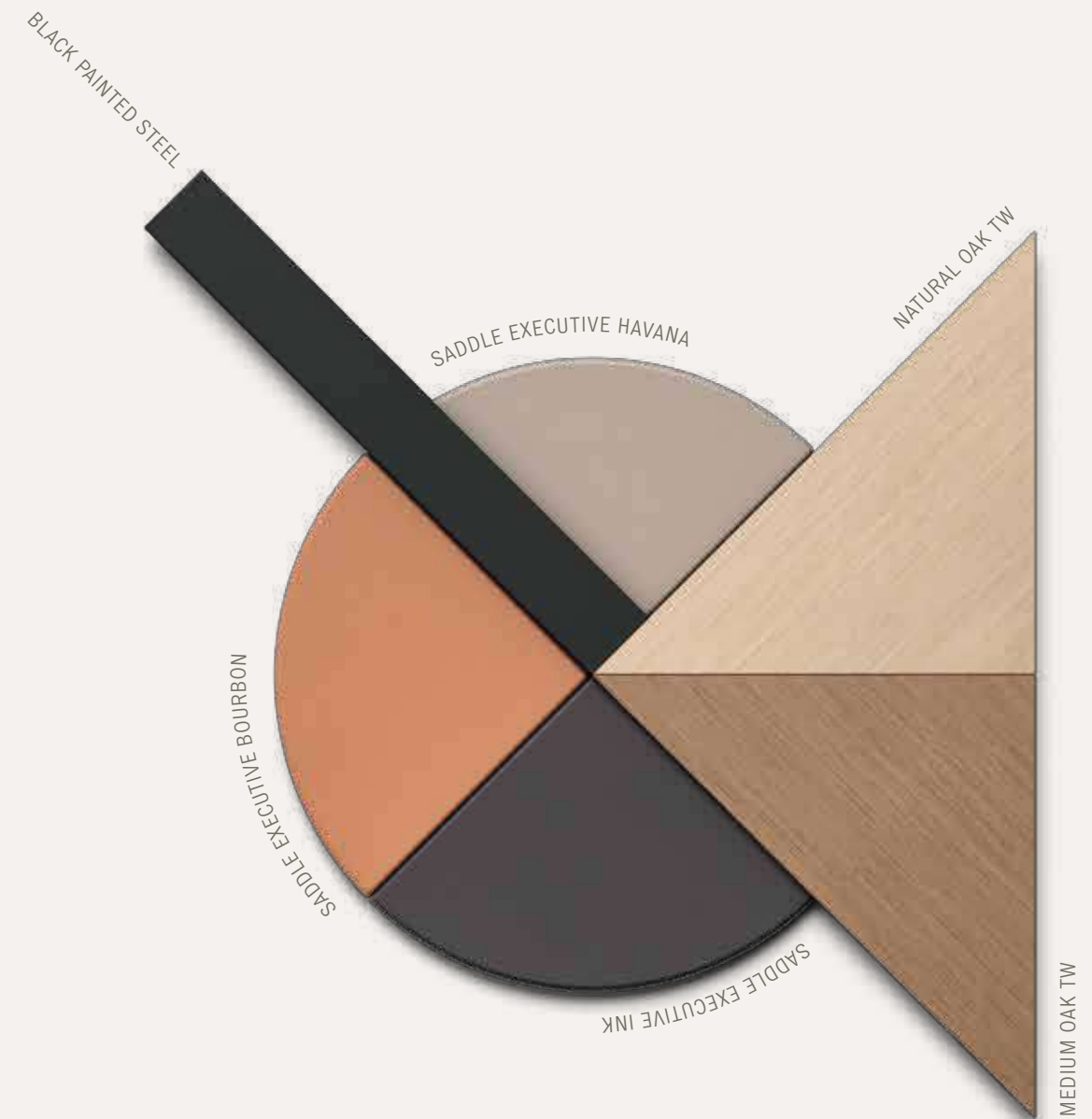



Le scrivanie Trust superano l'idea di desk tradizionale, distanziante e statico.

Il top annulla gli spigoli vivi, comunicando apertura e dialogo. I bordi smussati agevolano la postura di chi lavora alla scrivania, offrendo un appoggio confortevole. Due le versioni previste dal sistema, entrambe in tre dimensioni.

The Trust desks go beyond the idea of the traditional desk, separating and static.

The top is devoid of sharp corners, communicating openness and dialogue. The tapered edges facilitate the posture of those that work at the desk, providing comfortable support. The system comprises two versions, both of which come in three different sizes.

デスク「Trust」は、周囲と距離があつて固定されているという従来のデスクのイメージを変えるものです。

天板は尖った角をなくして、開かれた対話への意志を伝えます。縁も丸みをおびて、デスクに向かって働く人が身を持たせられるようにして姿勢の負担感をなくします。システムが提案する2つのバージョンはどちらも立体的です。

Trust写字台超越传统、疏远、静态的写字台概念。

顶面没有锐角，代表开放与对话。磨圆处理的边缘有助于在写字台上工作的人调整姿势，提供更加舒适的支撑。该系统提供两个版本，每个部分为三种尺寸。







↑ ↗ Trust Iconic Desk 214×107, Natural Oak TW with working pad in Saddle Executive Bourbon  
 ↑ Detail of the Natural Oak TW leg and of the top edge



Trust Iconic Desk, dalla sagoma mossata e irregolare, invita alla condivisione offrendo più lati e postazioni. La variante Trust Regular Desk mantiene invece la classica forma rettangolare che unisce alla morbidezza dei profili. Techno Wood con working pad in cuoio o pelle o, in alternativa, il piano interamente avvolto in cuoio o in pelle.

Trust Iconic Desk, with its wavy and irregular profile, encourages sharing, offering various sides and stations. The Trust Regular Desk variant maintains the classic rectangular form, which it combines with the smooth profiles. Techno Wood with saddle-leather or leather working pad or, alternatively, with the desktop completely upholstered in saddle-leather or leather.

Trust Iconic Deskはウェーブしたような不規則な形をしていて、より多くの面と配置を提供してシェアリングを誘います。このバリエーションにあたる「Trust Regular Desk」は逆に伝統的な長方形のフォルムが輪郭のやわらかさと結びついています。テクノ・ウッドにはなめし革またはレザーの作業用パッドが付属しますが、上面全体をなめし革かレザーでコーティングすることも可能です。

Trust Iconic Desk具有动态而不规则的外形，提供多个侧边和位置，适合分享。Trust Regular Desk款式则保持了长方形的经典外形，与柔软的外形轮廓相结合。Techno Wood搭配鞣制皮革或皮革工作垫，或者台面整体包裹鞣制皮革或皮革。



# Trust Iconic Desk

Top in Natural Oak TW with working pad in Saddle Executive leather, Bourbon colour.

Top in Saddle Executive leather, Havana colour.

Top in Saddle Executive leather, Havana colour.  
Natural Oak TW legs.  
(configuration C)



# Trust Iconic Desk with storage unit

Top in Natural Oak TW with working pad in Saddle Executive leather, Bourbon colour.  
Natural Oak TW leg.  
(configuration C)

The storage unit is equipped with two filing compartment drawers on the inner/user side and one compartment with a shelf and door accessible from the outer side for a better use.





Nella dimensione intermedia, tutti e due i modelli sono disponibili anche in versione asimmetrica: da un lato sostenuti da una gamba, dall'altro da un mobile contenitore.

In the intermediate size, both models are also available in an asymmetric version: supported by a leg on one side and by a cabinet on the other.

中間のサイズでは、両モデルとも左右非対称なバージョンをご用意できます。一方では脚に支えられ、もう一方はモジュールキャビネットが脚の役割をするというものです。

在中等尺寸中，两个款型均可选择不对称版本：一边采用支柱支撑，另一边采用收纳柜支撑。

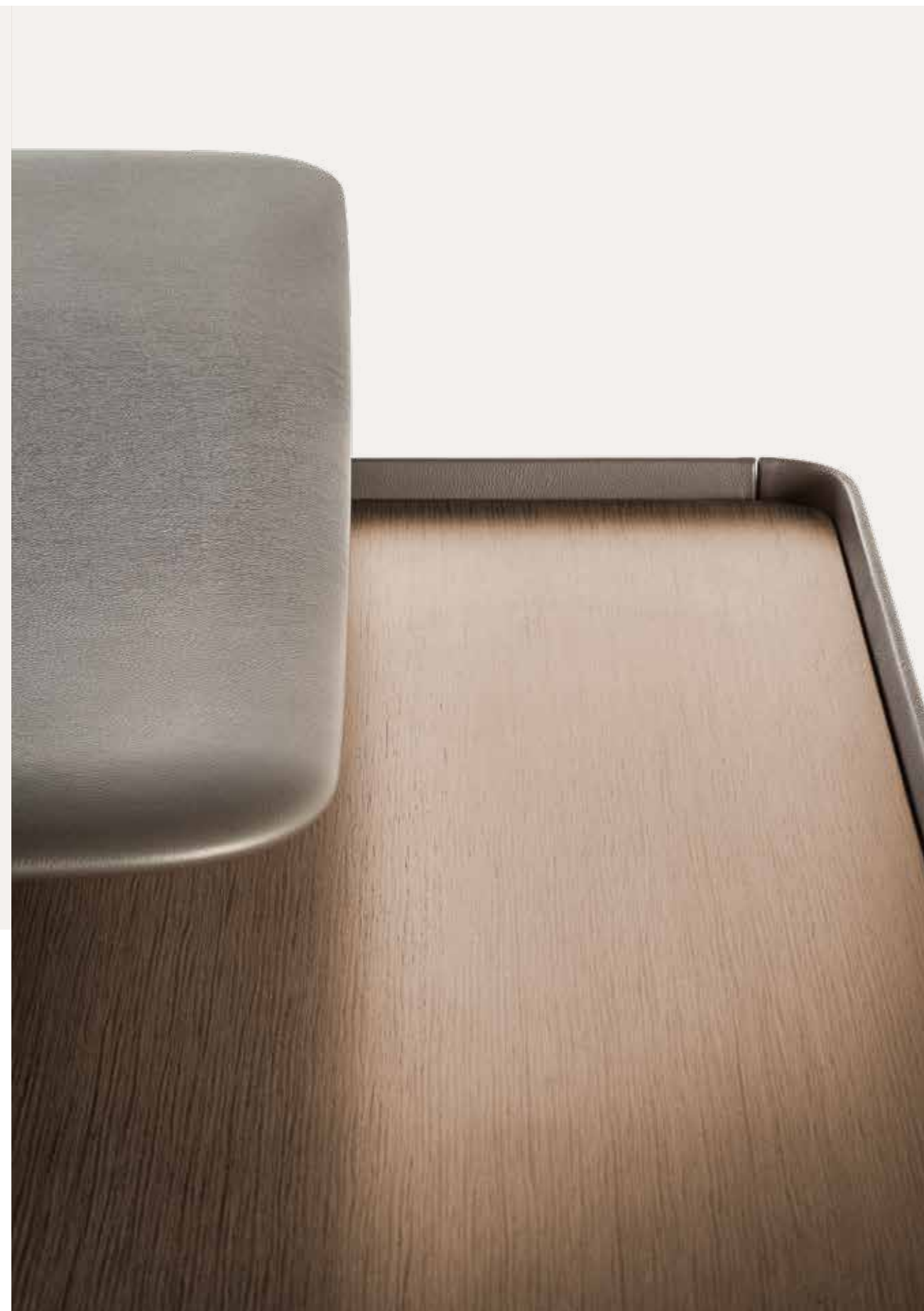

# Trust Regular Desk

Top in Medium Oak TW with working pad in Saddle Executive leather, Bourbon Ink.

Top in Saddle Executive leather, Ink colour.

Top and legs in Saddle Executive leather, Ink colour. (configuration D)



# Trust Regular Desk with storage unit

Top in Saddle Executive leather, Ink colour, with cable management door. Left leg in Saddle Executive leather, Ink colour. (configuration F)

The storage unit top is in Medium Oak TW. The exterior of the storage unit, including the front surfaces of the drawers, is upholstered in Saddle Executive leather, and the interior is black lacquered.







Cuoio/pelle o Techno-Wood anche per le gambe, concepite per permettere il passaggio dei cavi. Tutte le scrivanie, fatta eccezione per la Small, sono accessorabili con pannello di cortesia. La predisposizione passaggio cavi è fornita e personalizzata in base ai dispositivi di elettrificazione scelti e specificati dal cliente

Saddle-leather/leather or Techno Wood also for the legs, designed to accommodate cables. All of the desks, with the exception of the Small, can be accessorised with a modesty panel. The cable management feature is supplied and customised according to the electrical devices chosen and specified by the customer.

脚も、ケーブル通しを付けるとともに、なめし革/レザーまたはテクノ・ウッドでカバーすることが可能です。“スモール”以外のすべてのデスクにはコートジエパネルの取り付けが可能です。またお客様が特に選定した電化装置があれば、それに合わせてパーソナライズした形でケーブル通しが装備されます。

支柱也使用鞣制皮革/皮革或Techno-Wood，可以用于走线。所有写字台，除小号之外，均可配备随附面板。可以根据由客户选择并指定的电气化设备而配置并提供走线槽。

#### Trust Iconic Desk — Technical details of the cable management

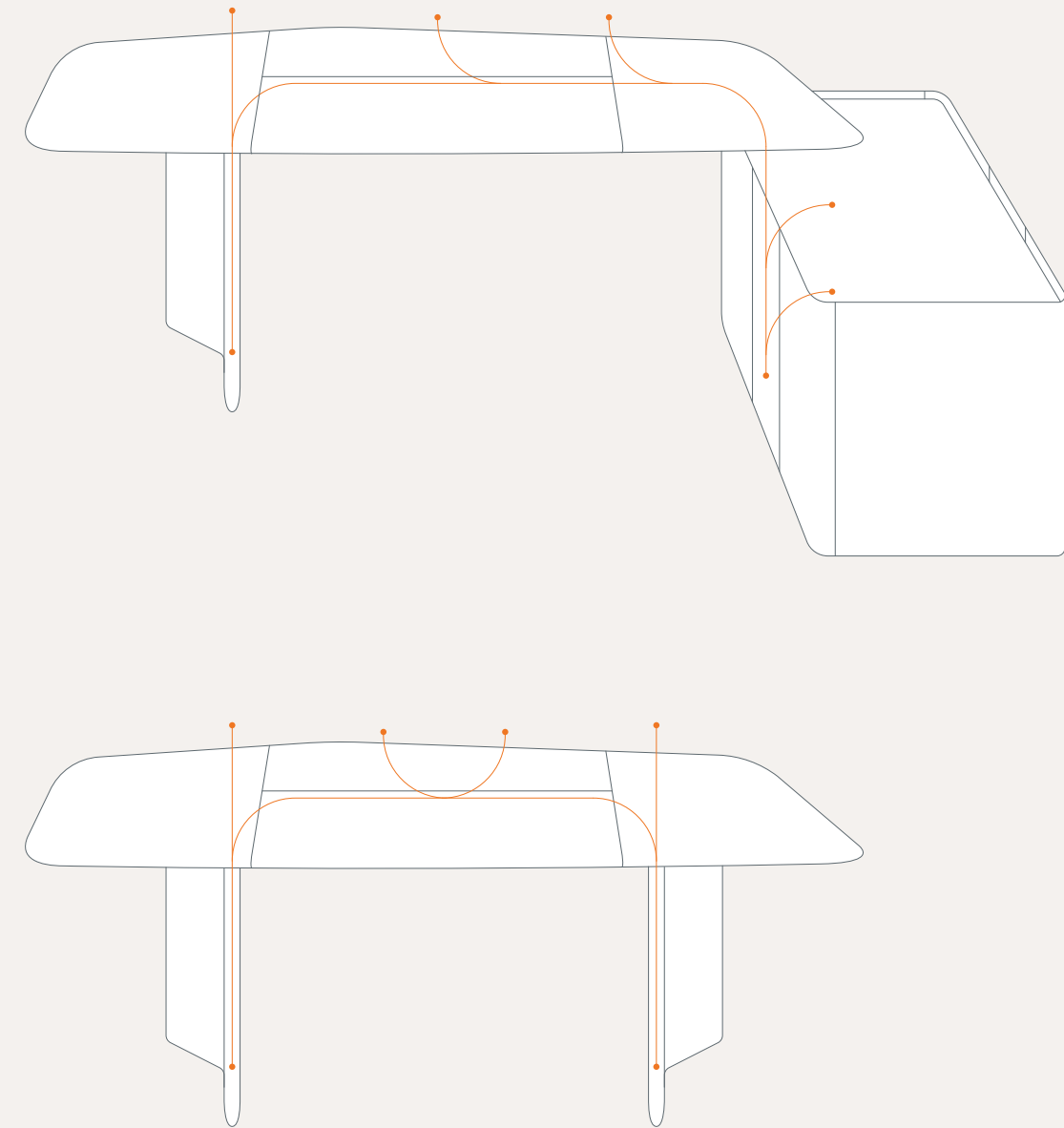

Please Note: The cable management system could be different according to the chosen finishes. For a complete information please refer to the current price list.





La scrivania Trust Iconic comprende la dimensione "large", ibrido versatile tra scrivania e tavolo riunioni. Mentre Trust Regular viene proposta anche nella dimensione "small", perfetta come accogliente postazione personale e come home desk.

The Trust Iconic desk also comes in a "large" size, a versatile hybrid between a desk and meeting table. Meanwhile, the Trust Regular also comes in a "small" size, perfect as a cosy personal workstation or home desk.

デスク「Trust Iconic」は「ラージ」サイズで、デスクと会議用テーブルが折衷された多機能タイプです。一方、「Trust Regular」には「スモール」サイズもあり、個人での使用や、家庭用デスクとしても理想的です。

Trust Iconic写字台提供“大号”尺寸，是写字台和会议桌的灵活结合。Trust Regular则提供“小号”尺寸，是个人舒适工作台和家庭书桌的理想选择。



## Trust Small Desk

Top in Saddle Executive leather,  
Havana colour.

Top in Saddle Executive leather,  
Havana colour.  
Natural Oak TW legs.  
(configuration A)



## Trust Small Desk with drawer unit

Top and leg in Saddle Executive  
leather, Bourbon colour.  
Drawer unit with top in Natural Oak  
TW.  
(configuration B)

The drawer unit is equipped with an  
external filing compartment drawer  
and an inner drawer. The outer  
surface, including the drawer, and  
the front surface of the inner drawer  
are upholstered in Saddle Executive  
leather to match the top of the desk.





Il top della cassettera presenta una fresatura per permettere l'uscita dei cavi elettrici dal cassetto interno (quando questa predisposizione viene richiesta come optional).

The top has a groove for the electrical cables coming through the inner drawer (when this option is requested).

天板には、内側の引き出しを通ってくる電気ケーブル用の溝があります(このオプションを希望する場合)。

顶部有一个凹槽，供穿过内抽屉的电线使用(当要求有此选项时)。

#### Trust Small Desk — Technical details of the cable management

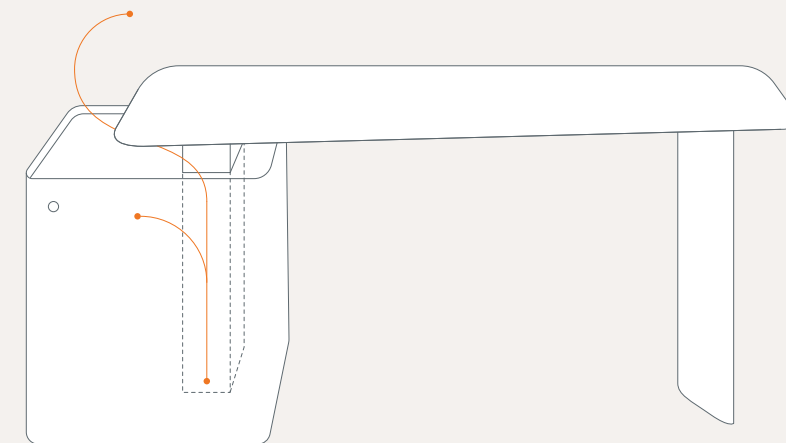

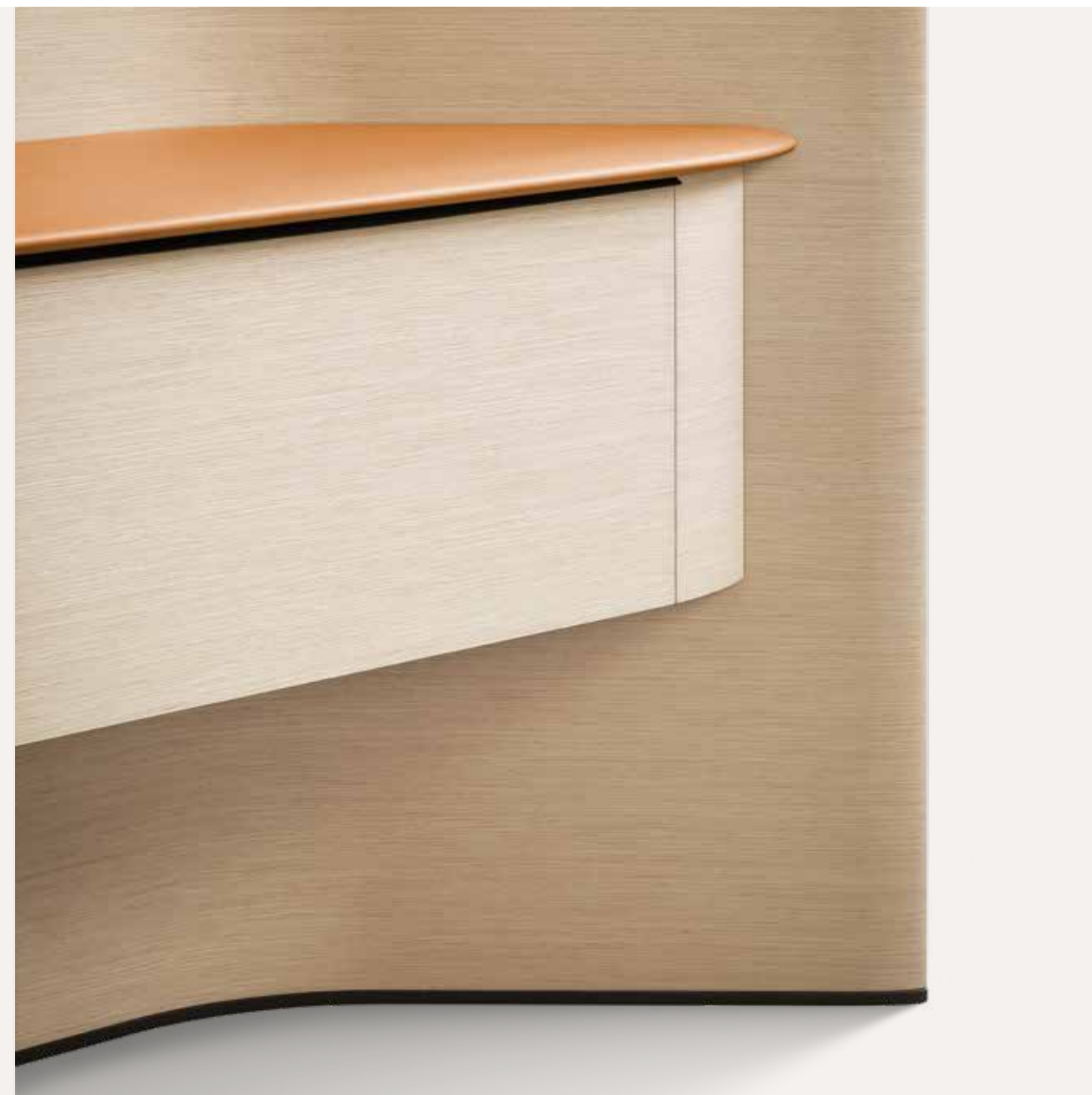

Le linee orizzontali dei desk giocano con le quinte verticali dei pannelli Trust Screen. Diaframmi sottili, dalle geometrie piane o curve, che permettono di delimitare gli spazi senza chiuderli. Di separare e raccogliere, senza allontanare. I pannelli, attrezzabili a piacere con mensole e contenitori, sono facilmente assemblabili e modulabili grazie al sistema autoportante per creare zone private all'interno dell'ambiente ufficio.

The horizontal lines of the desks dialogue with the vertical Trust Screen panels. Thin diaphragms, with flat or curved geometries, that allow you to delimit spaces without closing them. To separate and bring together, without distancing. The panels, which can be accessorised as desired with shelves and storage units, are easy to assemble and modular thanks to the self-supporting system to create private areas in the office environment.

デスクの横のラインと「Trust Screen」パネルの縦幕が楽しい視覚効果を生み出しています。平らなタイプとカーブしたタイプがある薄い仕切りが、完全な閉鎖空間にすることなくスペースを区切って、距離感を生み出すパーティション機能を実現します。パネルにはお好みで棚や収納ケースを付属させることができますが、自立タイプのシステムですので、モジュールの組み立ても簡単で、オフィス環境の中にプライベート・ゾーンを創り出すことができます。

写字台的水平线条与Trust Screen隔板的垂直板形成对比。纤细的隔层，具有平面或曲线几何形状，划分空间的同时不会导致封闭感。分割和收纳，但不远离。隔板上可以根据喜好搭配架板和收纳柜，凭借自承重系统可以分成模块并轻松组装，在办公室环境中创造私人区域。





La struttura dei pannelli Trust Screen è in fibra di legno a media densità impiallacciata in Rovere Techno-wood. La finitura può essere in Rovere naturale o medio. I piedi sono in acciaio verniciato color ardesia. A richiesta è disponibile anche un gancio appendiabiti. Le mensole, fissate in sospensione, sono composte da due ripiani e un montante centrale rivestiti in Pelle Frau® o cuoio Saddle Executive.

The structure of the Trust Screen panels is in MDF with a Techno-Wood oak veneer. Finish in natural or medium oak. The feet are in slate-coloured steel. A clothes hook is also available on request. The suspended shelves consist of two surfaces and a central pillar and are covered in Pelle Frau® leather or Saddle Executive leather.

Trust Screenのパネル構造は中密度ウッドファイバー (MDF) 製で、オークカラーのテクノ・ウッドで化粧張りされており、ナチュラルまたはミディアムオークカラー仕上げをお選びいただけます。スチール製の脚はスレートカラー塗装されています。また、「Trust Screen」にはお好みで棚がキャビネットを追加することもできます。ご要望に応じて、ハンガーフックもご提供が可能です。吊りタイプの固定棚は2段式で、中仕切りは Pelle Frau® またはなめし革 Cuoio Saddle Executive で上張りされています。

Trust Screen隔板结构采用中密度木纤维，贴面为无梗花栎木Techno-wood。表面处理采用天然或中等无梗花栎木。支脚采用板岩色喷漆钢。如有需要，也可以搭配一个挂衣钩。架板悬空固定，由两个隔层板和一个中央支柱组成，覆盖Pelle Frau®皮革或Saddle Executive鞣制皮革。



Trust  
Screen

---

Screen 4 modules (configuration 5 )  
Natural Oak TW

---

Screen 4 modules with large shelves  
(configuration 6 )  
Natural Oak TW and Saddle Executive  
leather, Ink colour.

---

Screen 4 modules with large cabinet  
(configuration 7 )  
Medium Oak TW and Saddle Executive  
leather, Havana colour.

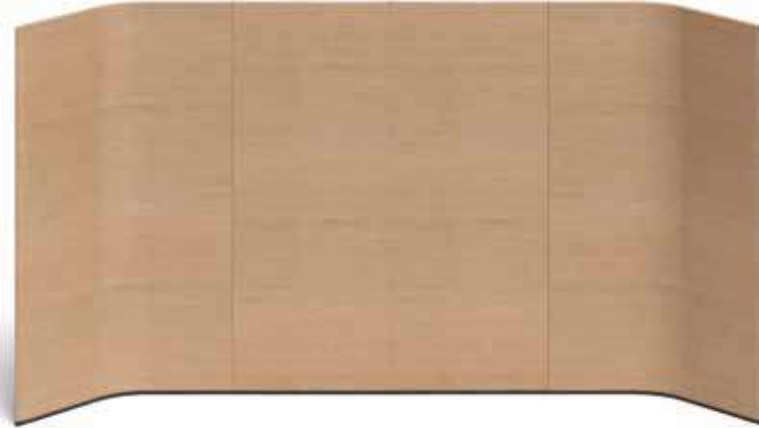
Trust  
Screen

---

Corner screen DX 6 modules with large  
frontal shelves (configuration 17 )  
Natural Oak TW and Saddle Executive  
leather, Havana colour.

---

Corner screen DX 6 modules with large  
frontal cabinet (configuration 19 )  
Medium Oak TW and Saddle Executive  
leather, Bourbon colour.



Trust Screen può essere completato a piacere da mensole o cabinet in due diverse dimensioni e integrato con accessori per il passaggio cavi, la canalina, che consente il passaggio del cavo all'interno del pannello Screen, o il pannello appendiabiti passacavi.

Trust Screen can be completed as desired with shelves or cabinets in two different sizes and integrated with cable management accessories, a raceway, which enables cables to pass through the Screen panel, or a cable management clothes stand panel.

棚とキャビネットは大小2サイズ展開で、「Screen」にケーブルを通すためのケーブル通しと導管、またはケーブル用ハンガーパネルなどのアクセサリ類と組合わされています。

Trust Screen隔板可以随意搭配架板或收纳柜，分为两种尺寸，可以整合走线配件、走线管，将缆线从Screen隔板内部穿过，或者用于走线的挂衣板。

#### Trust Screen — Technical details of the cable management

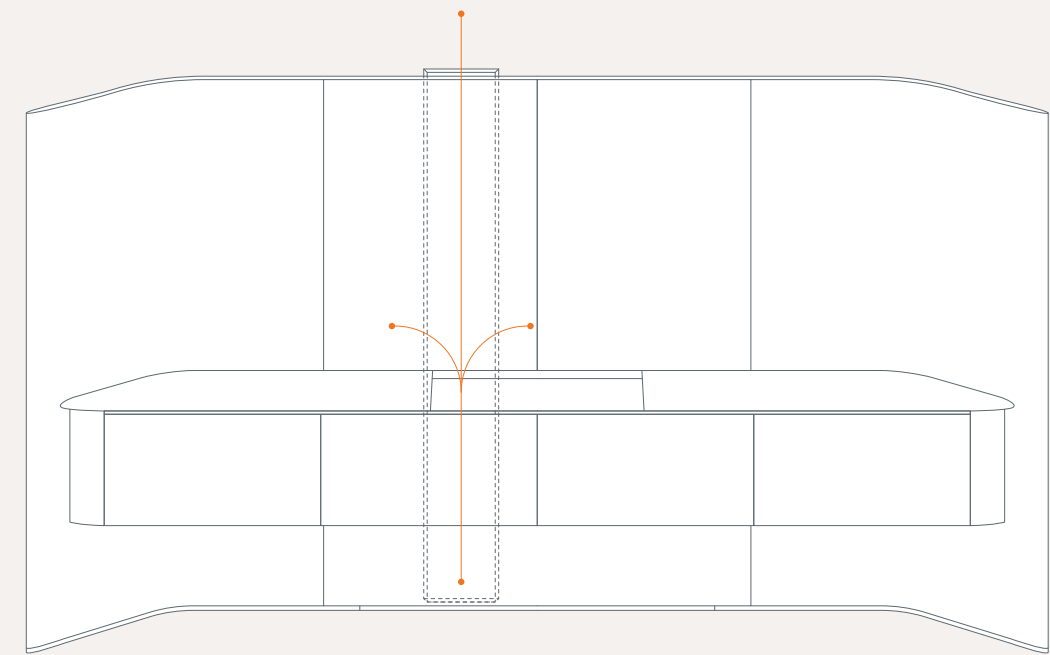





Il sistema Trust si completa con due tipologie di contenitori per l'archiviazione: la cassetiera Trust Drawer e la credenza Trust Cabinet. La struttura portante di entrambi è in fibra di legno a media densità. Il top è in Techno Wood, nelle finiture Rovere naturale e medio. Cuoio Saddle Executive nelle tonalità Havana o Bourbon Ink o Pelle Frau® ColorSphere® per il rivestimento esterno e i cassetti richiamano gli altri elementi della collezione

The Trust system is completed with two kinds of storage units: the Trust Drawer and the Trust Cabinet. The supporting structure of both is in MDF. The top is in Techno Wood, in the finishes natural and medium oak. Cuoio Saddle Executive in the tones Havana or Bourbon Ink or Pelle Frau® leather from the ColorSphere® for the exterior upholstery and the drawers recall the other elements of the collection.

システム「Trust」は、アーカイブ用の収納ケースの2タイプ、ドロワーユニット「Trust Drawer」と棚「Trust Cabinet」で構成されています。両方とも構造部分には中密度ウッドファイバー（MDF）製です。天板はナチュラル/ミディアムオークで仕上げられたテクノ・ウッドです。外側のカバー材は、「ハヴァナ」色または「ブルボン・インク」色のCuoio Saddle Executive、あるいは「カラー・システム」仕上げのPelle Frau®で、ドロワーユニットにはコレクションの他の構成要素が使用されます。

Trust系统提供两类档案柜：Trust Drawer 抽屉柜和Trust Cabinet边柜。两者支撑结构均采用中密度木纤维。顶面采用Techno Wood天然和中等无梗花栎木表面处理。外表和抽屉覆盖Havana或Bourbon Ink色Cuoio Saddle Executive鞣制皮革，或Pelle Frau® ColorSphere®皮革，呼应该系列的其它元素。





166

## Trust Drawer unit

---

Top in Natural Oak TW.  
Covering in Saddle Executive leather,  
Havana colour.

---

The drawer chest is equipped with  
a single external drawer with filing  
compartments and an inner drawer  
also with a front surface upholstered  
in leather or saddle-leather to match  
the exterior.



## Trust Cabinet

---

Top in Medium Oak TW.  
Covering in Saddle Executive leather,  
Ink colour.

---

The cabinet has three compartments  
with doors that open to 155°. The  
central compartment is larger and  
comes with an inner shelf.





Le ante hanno la chiusura ammortizzata ed è possibile eliminare o graduare la potenza di frenatura dell'anta grazie a un cursore predisposto su ogni cerniera. Le ante sono dotate di serratura con chiave valida anche per l'accesso al vano posteriore passacavi. Quest'ultimo è posizionato sul retro ed è accessibile tramite sportello ribaltabile. La predisposizione passaggio cavi è fornita e personalizzata in base ai dispositivi di elettrificazione scelti e specificati dal cliente.

The doors have a soft closing mechanism and it is possible to eliminate or graduate the door's braking power using a cursor found on each hinge. The doors have a lock and key which can also be used to access the rear cable management compartment. The latter is positioned at the back and can be accessed via the tilting door. The cable management feature is supplied and customised according to the electrical devices chosen and specified by the customer.

扉はソフトクローズ機能が搭載された開閉方式をとり、ヒンジに設置されているカーソルを使って制御力を軽減したり、なくしたりすることが可能です。扉の開閉用の鍵はケーブル用スペースへのアクセスにも使用できます。ケーブル用スペースは後部に配備されており、上げ起こし式の扉からアクセスします。またお客様が特に選定した電化装置があれば、それに合わせてパーソナライズした形でケーブル通しが装備されます。

门板配备缓冲闭合装置，利用每个铰链上的销扣，可以减小或增大门板制动力。门板上锁，钥匙同样适用于打开后侧走线槽。走线槽位于背板上，通过翻斗门打开。可以根据客户选择并指定的电气化设备而配置并提供走线槽。

#### Trust Cabinet — Technical details of the cable management

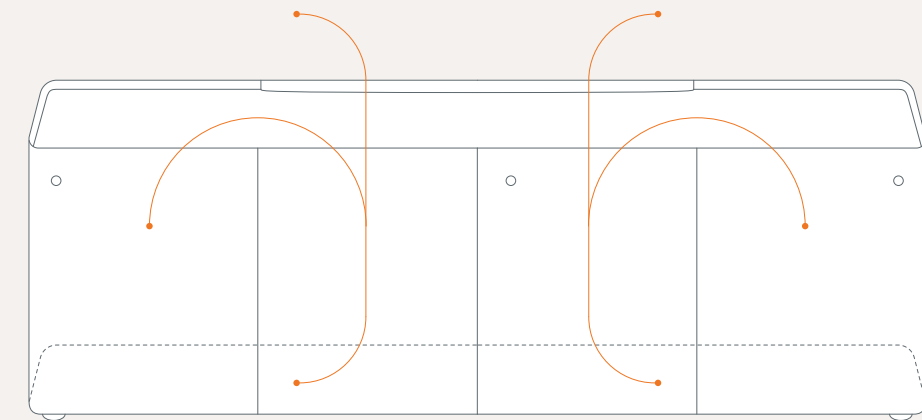

Small Desk 145×68 — Leather top, wood legs

5644700 | A

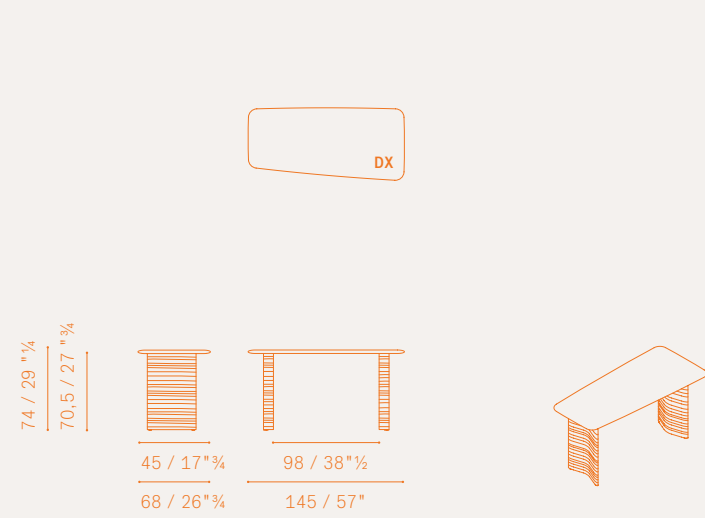

Small Desk 145×68 — Leather top, leather legs

5644700 | B

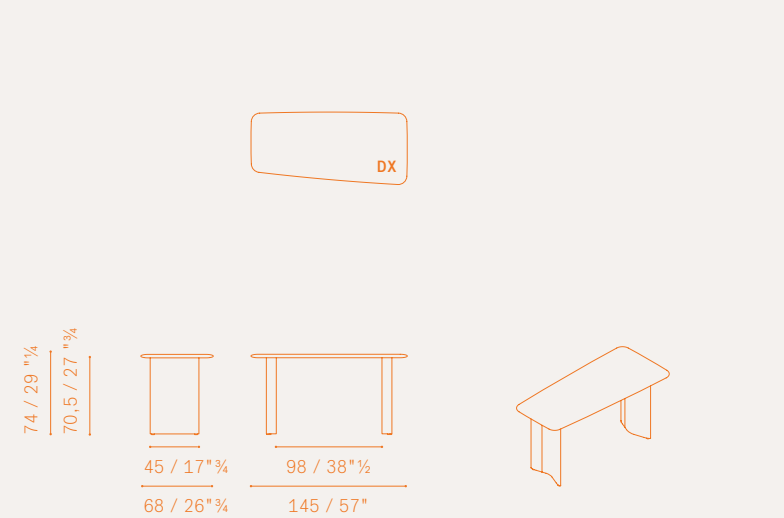

Small Desk 145×68 with storage unit

5644710 | B

Leather top  
Leather leg  
Grooving of the drawer unit top for the cable management exit  
Cable management arrangement in the column connecting the storage unit and the top

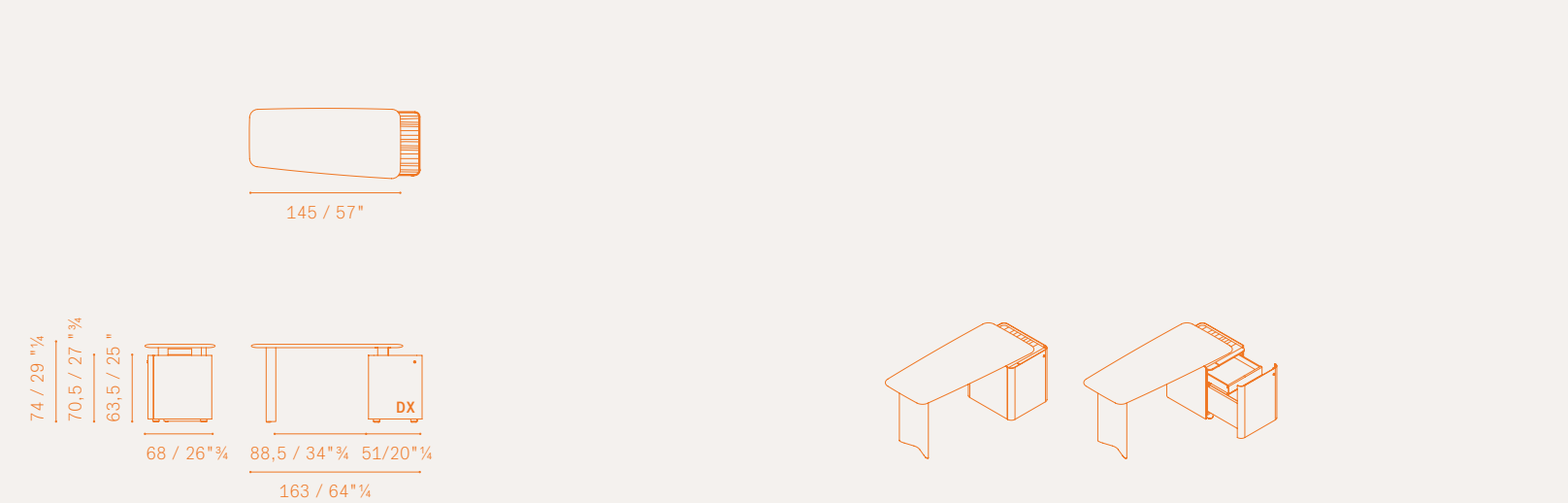

Small Desk 145×68 with storage unit

5644710 | A

Leather top  
Wood leg  
Grooving of the drawer unit top for the cable management exit  
Cable management arrangement in the column connecting the storage unit and the top

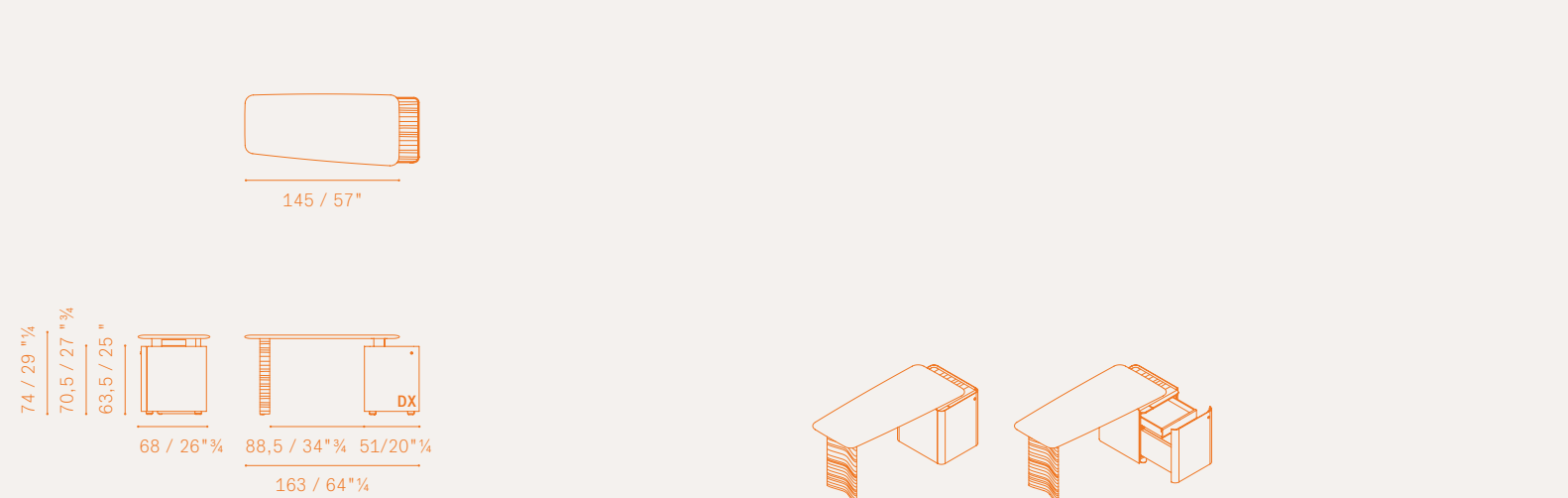

Regular Desk 183X92

5644701 | A

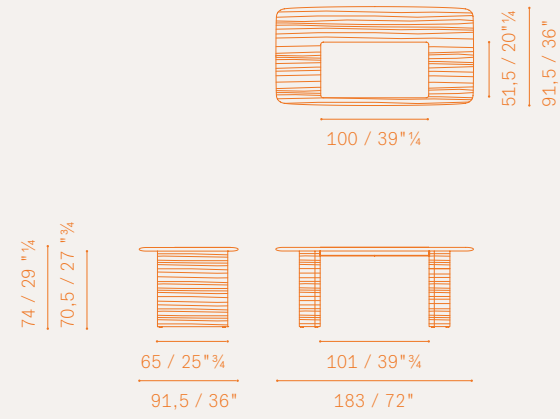

Regular Desk 183X92

5644701 | B

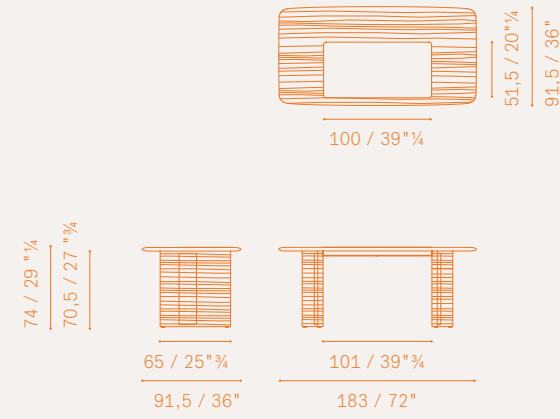

**Please note:**  
this catalogue shows only some technical drawings, in order to know all the availabilities please refer to the current price list.

5644701 | G

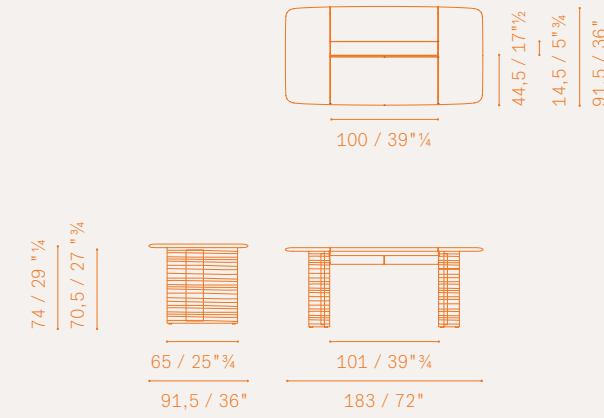

5644701 | H

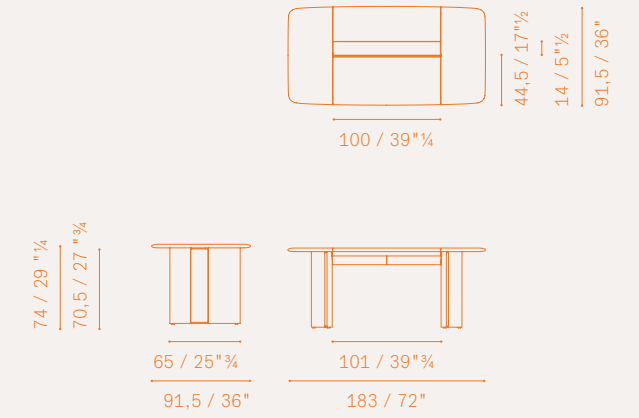

5644701 | C

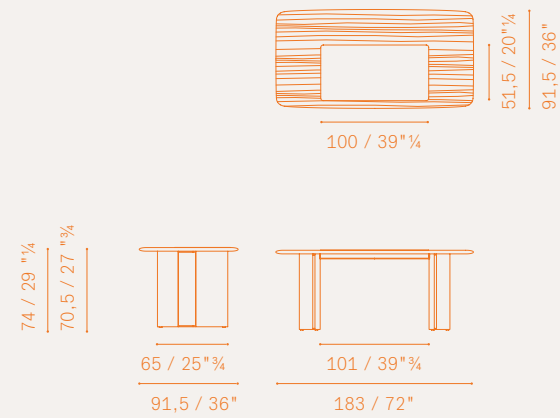

5644701 | D

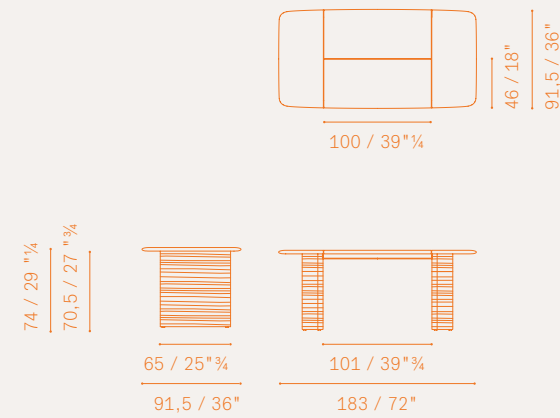

5644701 | I

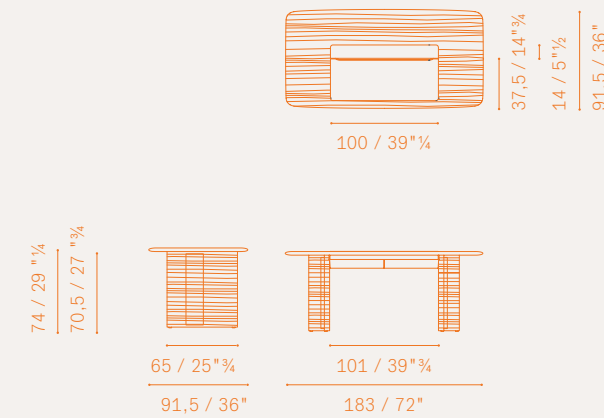

5644701 | J

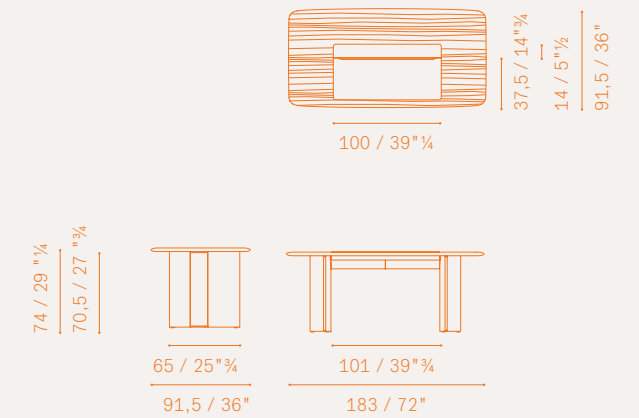

5644701 | E

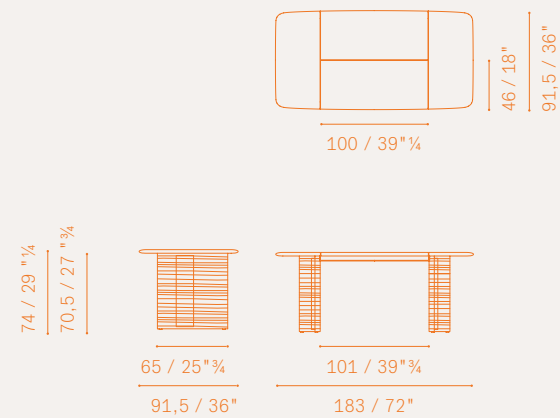

5644701 | F

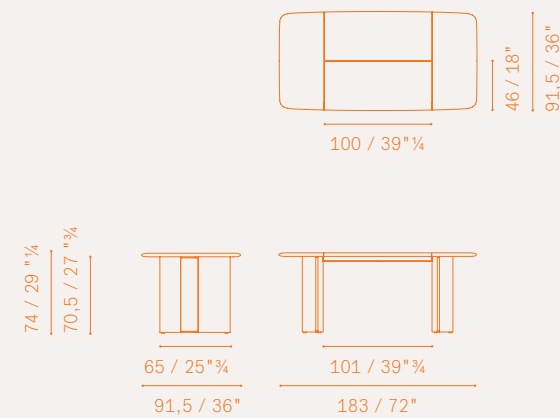



# Trust — Regular Desk 183×92



A

Wood top  
Leather working pad  
Wood legs

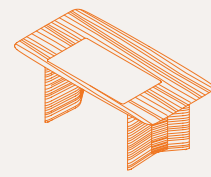

B

Wood top  
Leather working pad  
Wooden legs with cable management area

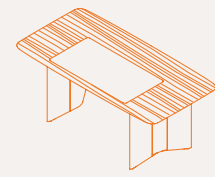

C

Wood top  
Leather working pad  
Leather legs with cable management area

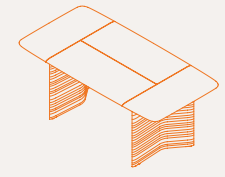

D

Leather top  
Wood legs

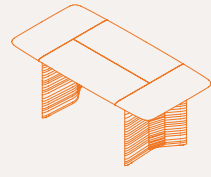

E

Leather top  
Wooden legs with cable management area

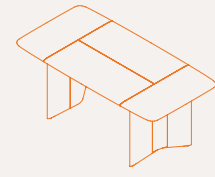

F

Leather top  
Leather legs

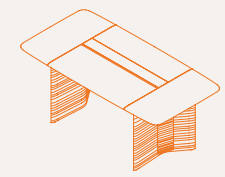

G

Leather top with cable management door  
Wooden legs with cable management area

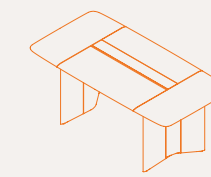

H

Leather top with cable management door  
Leather legs with cable management area

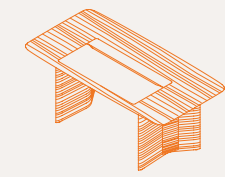

I

Wood top  
Leather working pad with cable management door  
Wooden legs with cable management area

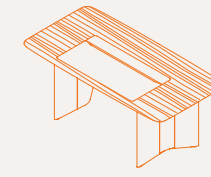

J

Wood top  
Leather working pad with cable management door  
Leather legs

# Trust — Regular Desk 214×107

5644702 | A

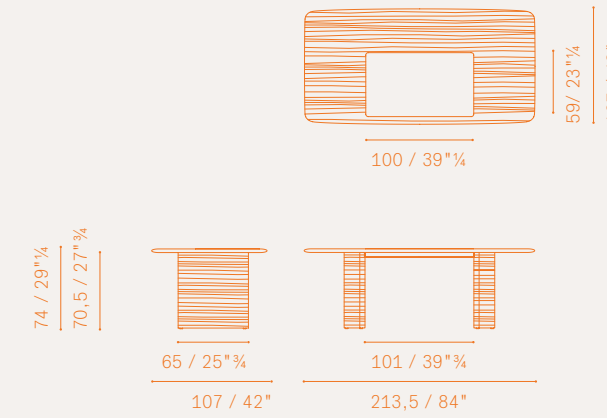

5644702 | A

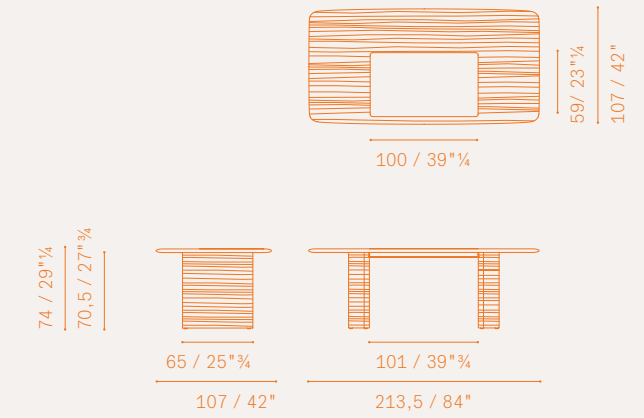

5644702 | B

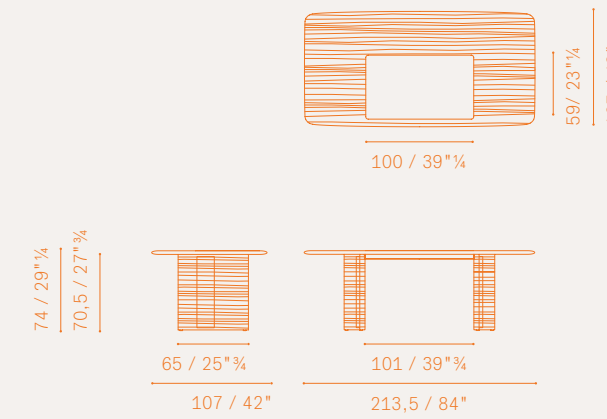

5644702 | C

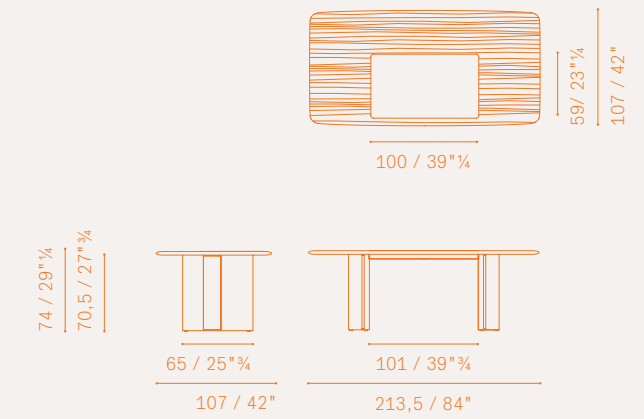

5644702 | D

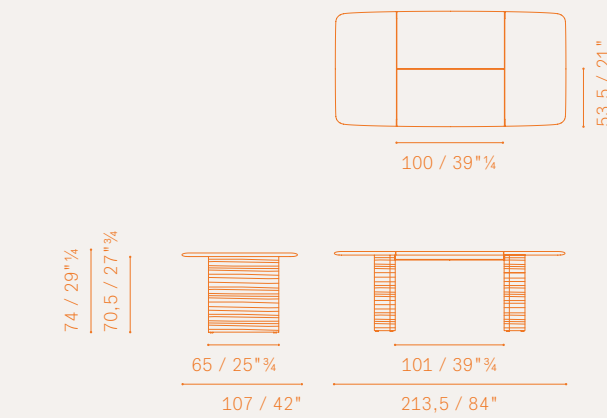

5644702 | E

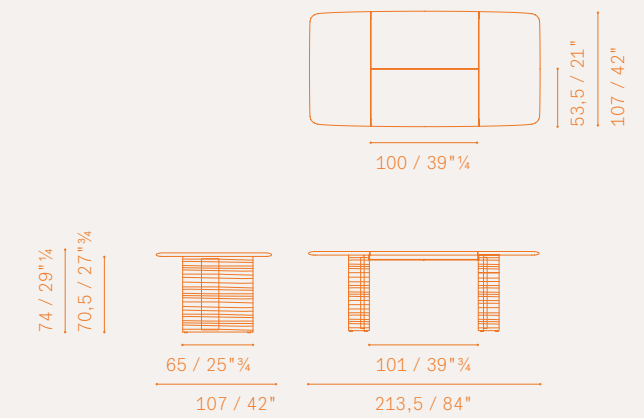

5644702 | F

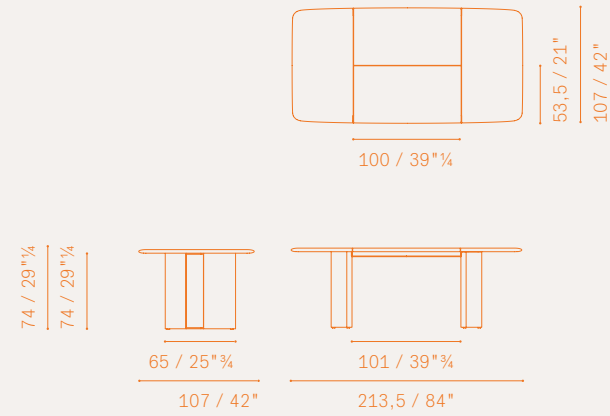

5644702 | G

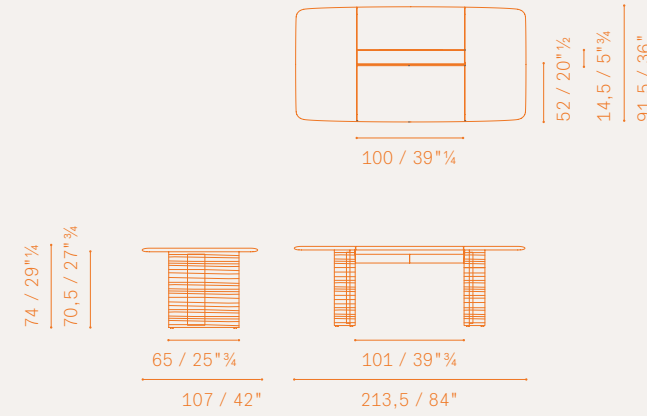

5644702 | H

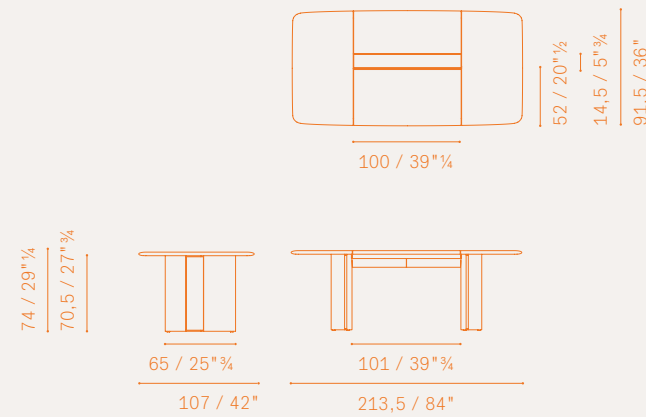

5644702 | I

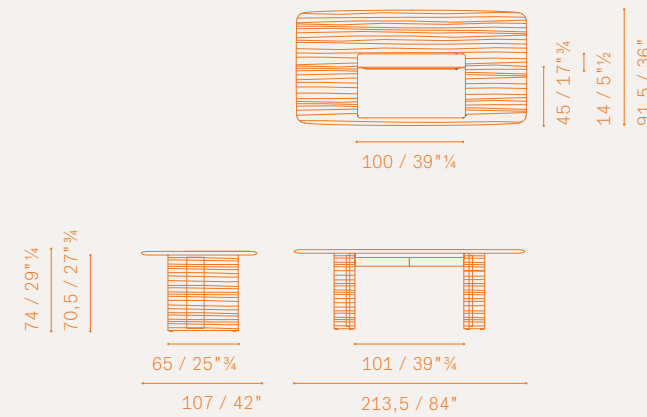

5644702 | J

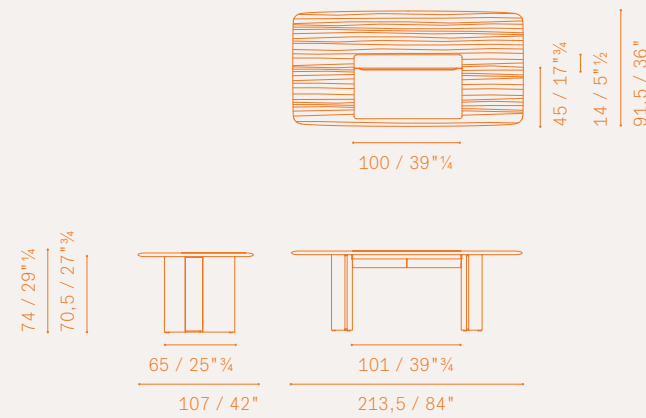

Please note:

this catalogue shows only some technical drawings, in order to know all the availabilities please refer to the current price list.

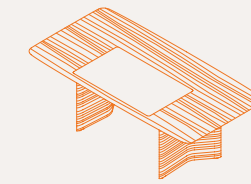

A

Wood top  
Leather working pad  
Wood legs

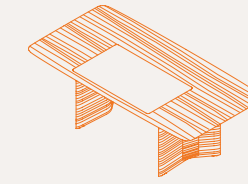

B

Wood top  
Leather working pad  
Wooden legs with cable management area

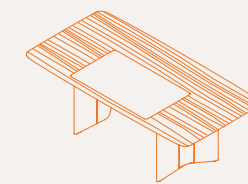

C

Wood top  
Leather working pad  
Leather legs with cable management area

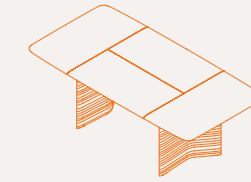

D

Leather top  
Wood legs

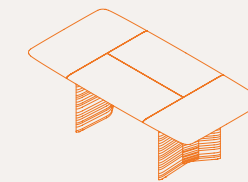

E

Leather top  
Wooden legs with cable management area

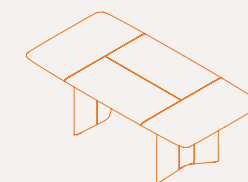

F

Leather top  
Leather legs

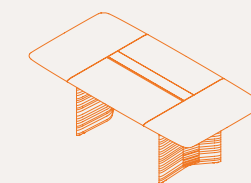

G

Leather top with cable management door  
Wooden legs with cable management area



H

Leather top with cable management door  
Leather legs with cable management area

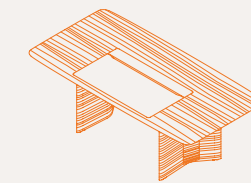

I

Wood top  
Leather working pad with cable management door  
Wooden legs with cable management area

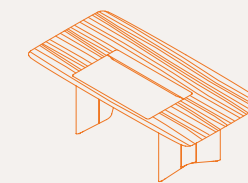

J

Wood top  
Leather working pad with cable management door  
Leather legs

5644705 | A

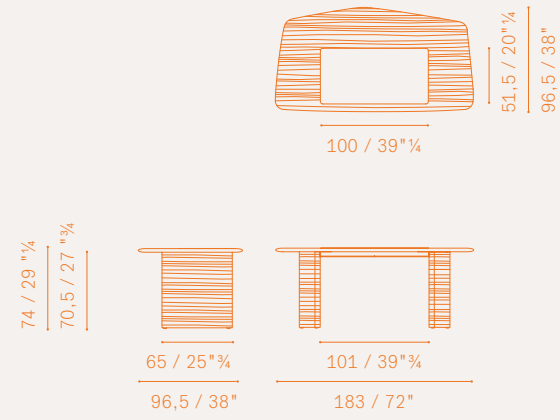

5644705 | B

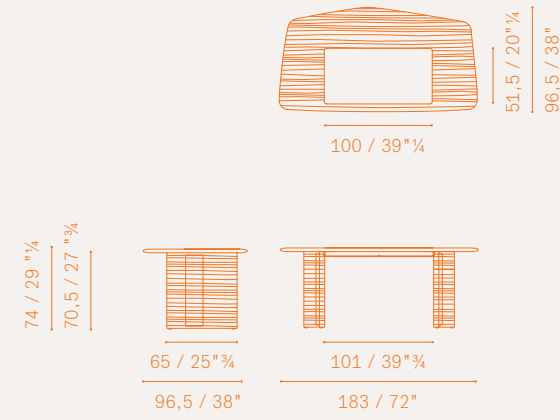

5644705 | G

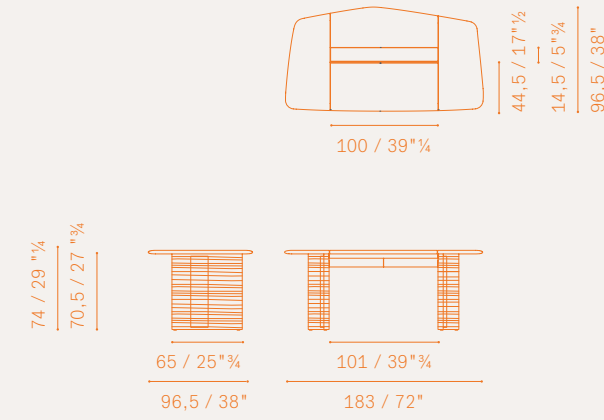

5644705 | H

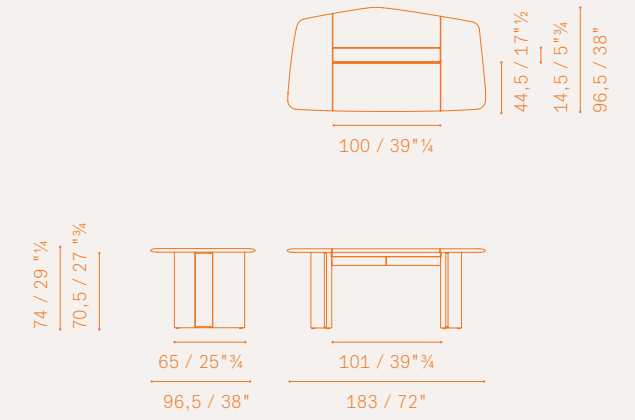

5644705 | C

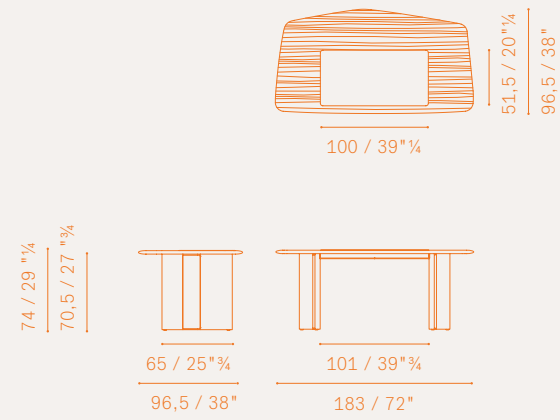

5644705 | D

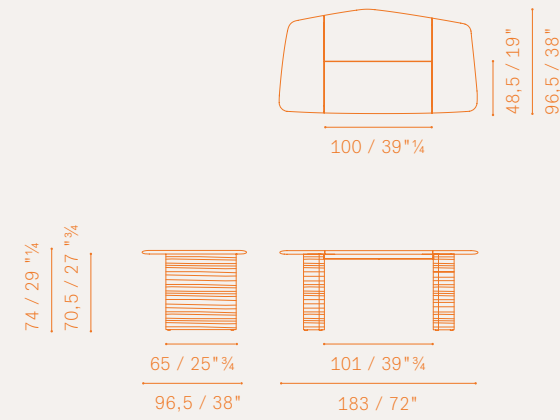

5644705 | I

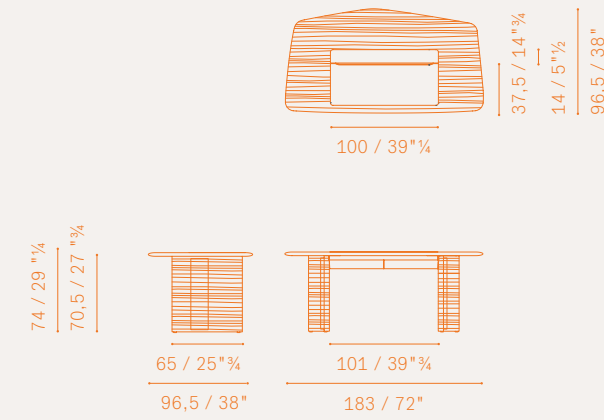

5644705 | J

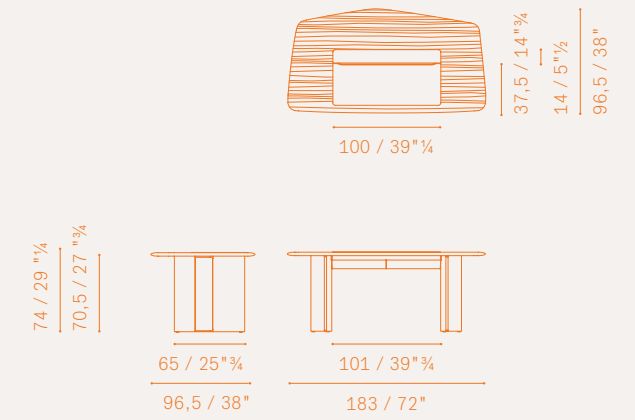

5644705 | E

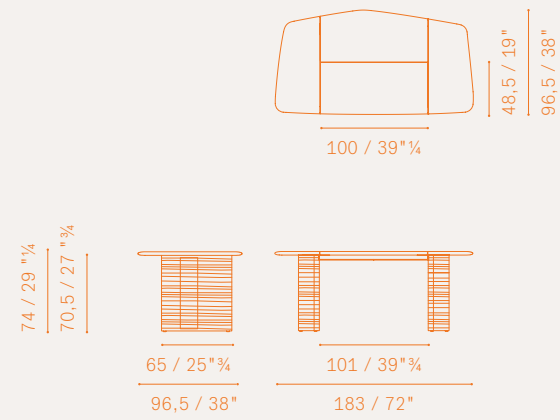

5644705 | F

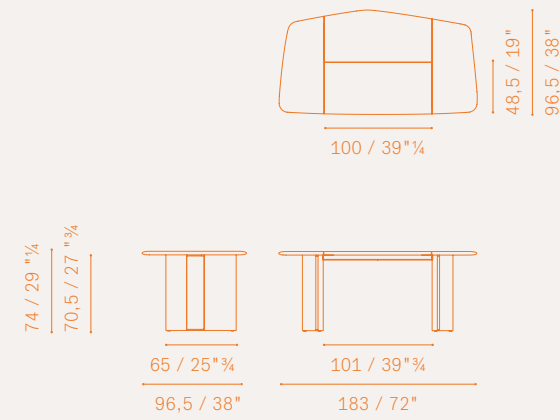

**Please note:**

this catalogue shows only some technical drawings, in order to know all the availabilities please refer to the current price list.

# Trust — Iconic Desk 183×97



A

Wood top  
Leather working pad  
Wood legs

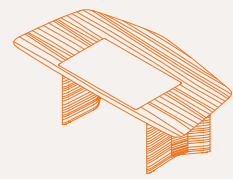

B

Wood top  
Leather working pad  
Wooden legs with cable management area

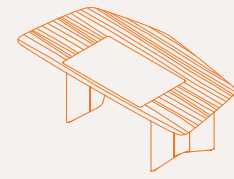

C

Wood top  
Leather working pad  
Leather legs with cable management area

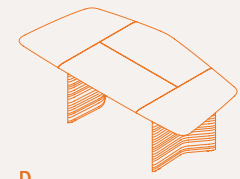

D

Leather top  
Wood legs

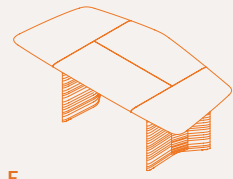

E

Leather top  
Wooden legs with cable management area

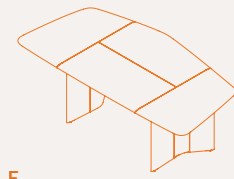

F

Leather top  
Leather legs

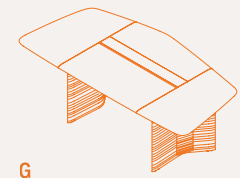

G

Leather top with cable management door  
Wooden legs with cable management area

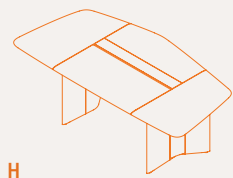

H

Leather top with cable management door  
Leather legs with cable management area

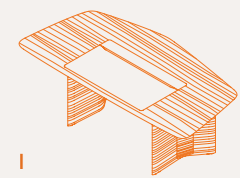

I

Wood top  
Leather working pad with cable management door  
Wooden legs with cable management area

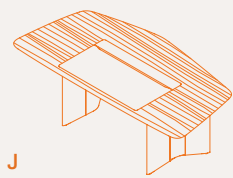

J

Wood top  
Leather working pad with cable management door  
Leather legs

# Trust — Iconic Desk 214×107

5644706 | A

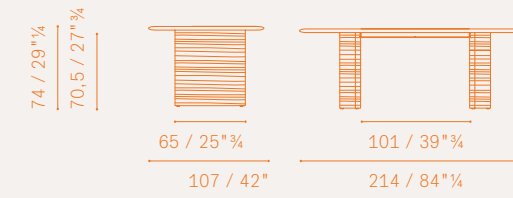
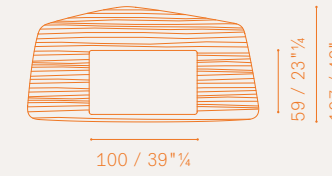

5644706 | B

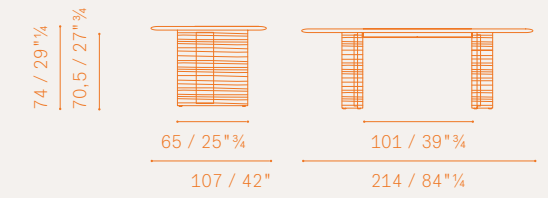
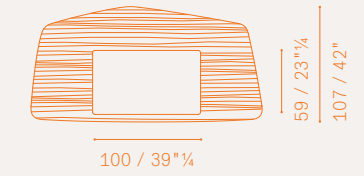

5644706 | C

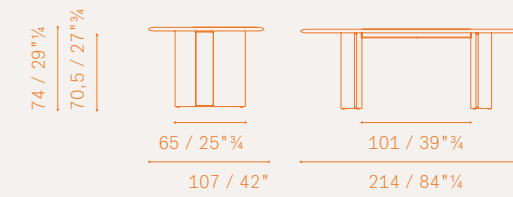
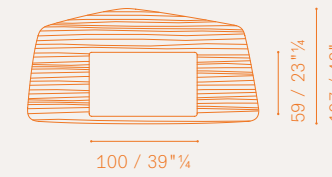

5644706 | D

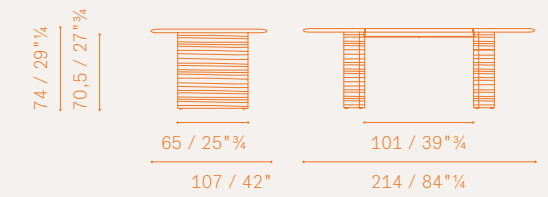
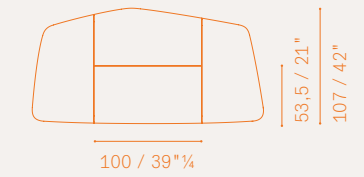

5644706 | E

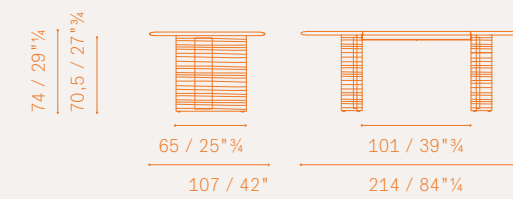
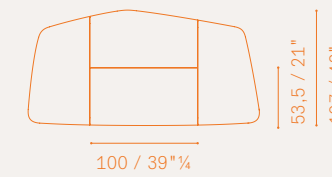

5644706 | F

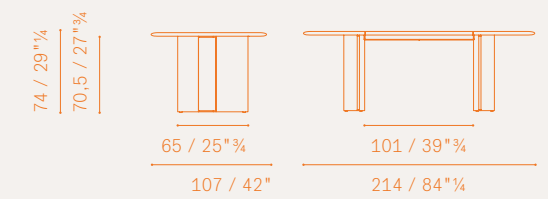
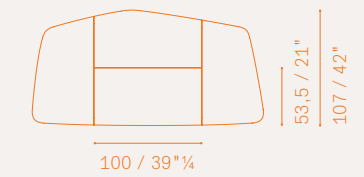



5644706 | G

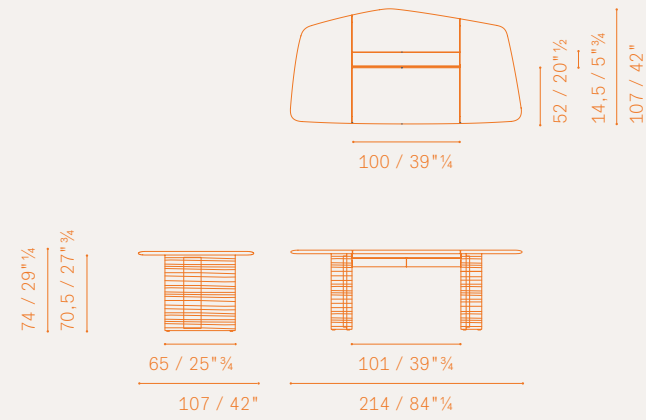

5644706 | H

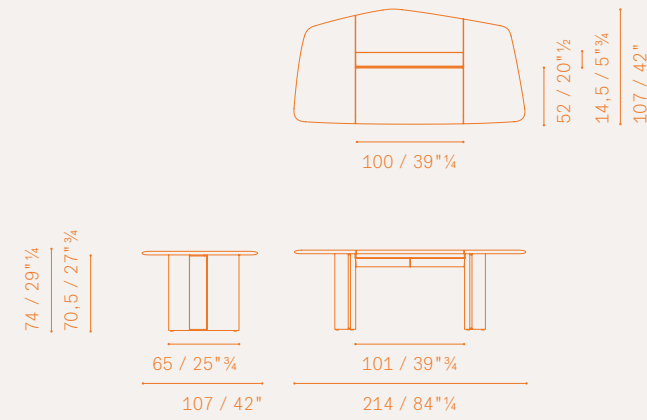

5644706 | I

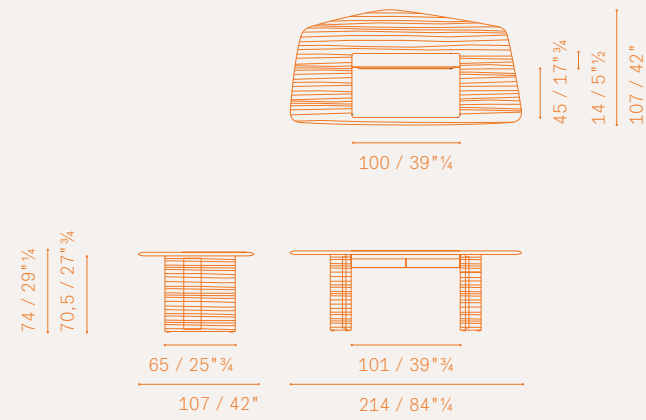

5644706 | J

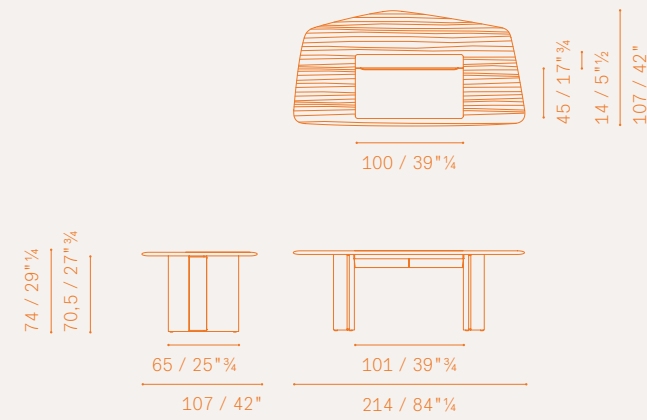

**Please note:**

this catalogue shows only some technical drawings, in order to know all the availabilities please refer to the current price list.



A

Wood top  
Leather working pad  
Wood legs

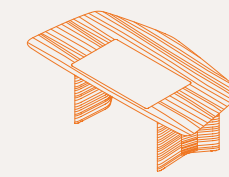

B

Wood top  
Leather working pad  
Wooden legs with cable management area

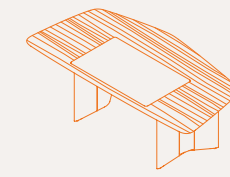

C

Wood top  
Leather working pad  
Leather legs with cable management area

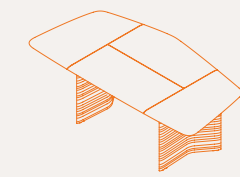

D

Leather top  
Wood legs

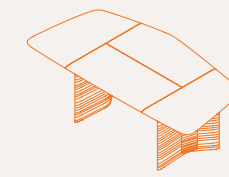

E

Leather top  
Wooden legs with cable management area

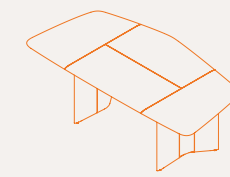

F

Leather top  
Leather legs

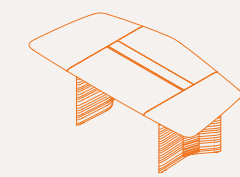

G

Leather top with cable management door  
Wooden legs with cable management area

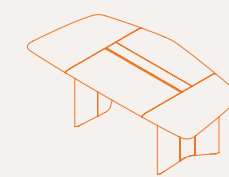

H

Leather top with cable management door  
Leather legs with cable management area

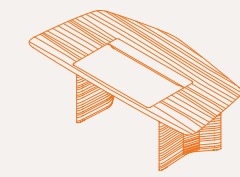

I

Wood top  
Leather working pad with cable management door  
Wooden legs with cable management area

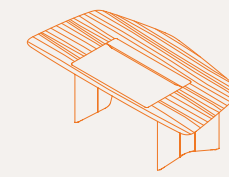

J

Wood top  
Leather working pad with cable management door  
Leather legs



# Trust — Iconic Desk 228×137

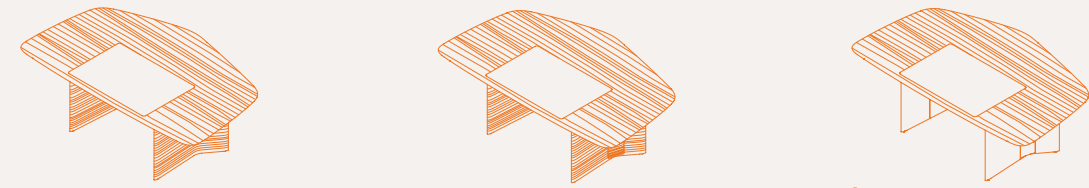

**A** Wood top  
Leather working pad  
Wood legs

**B** Wood top  
Leather working pad  
Wooden legs with cable management area

**C** Wood top  
Leather working pad  
Leather legs with cable management area

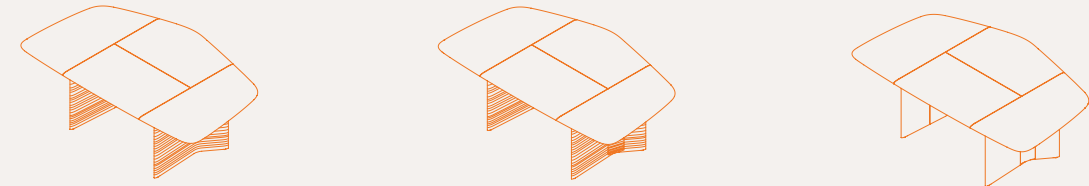

**D** Leather top  
Wood legs

**E** Leather top  
Wooden legs with cable management area

**F** Leather top  
Leather legs

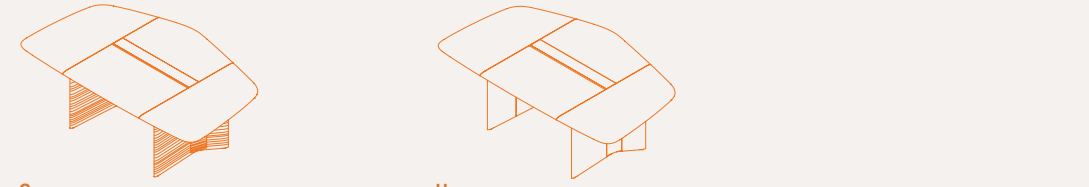

**G** Leather top with cable management door  
Wooden legs with cable management area

**H** Leather top with cable management door  
Leather legs with cable management area

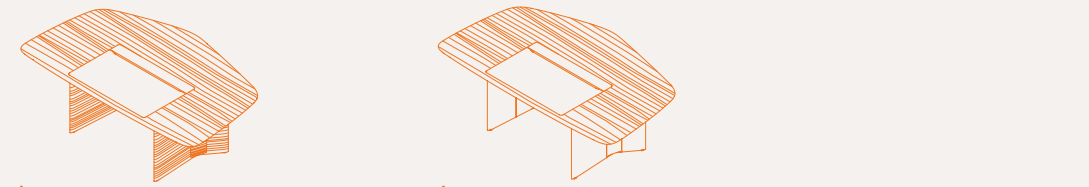

**I** Wood top  
Leather working pad with cable management door  
Wooden legs with cable management area

**J** Wood top  
Leather working pad with cable management door  
Leather legs

# Trust — Regular Desk 214×107 with storage unit 187

5644711 | A

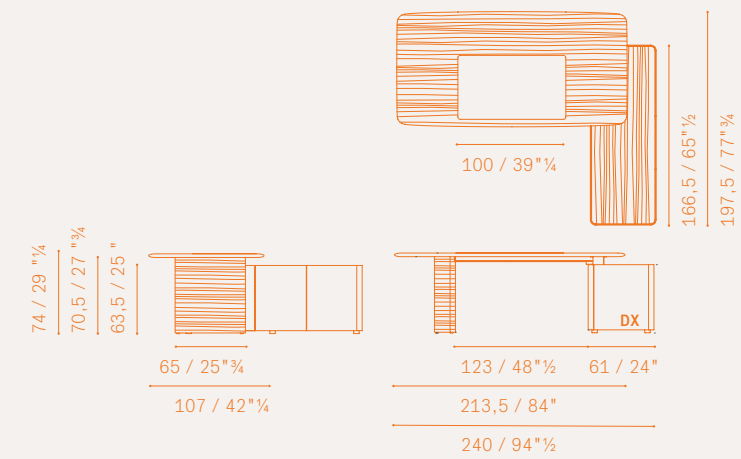

5644711 | B

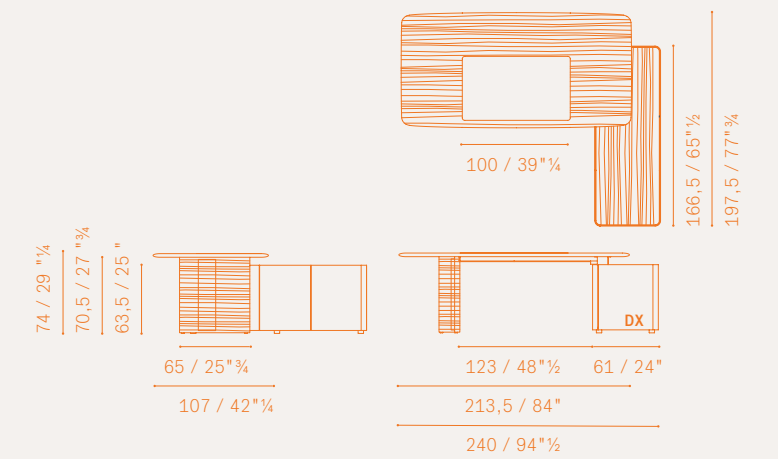

5644711 | C

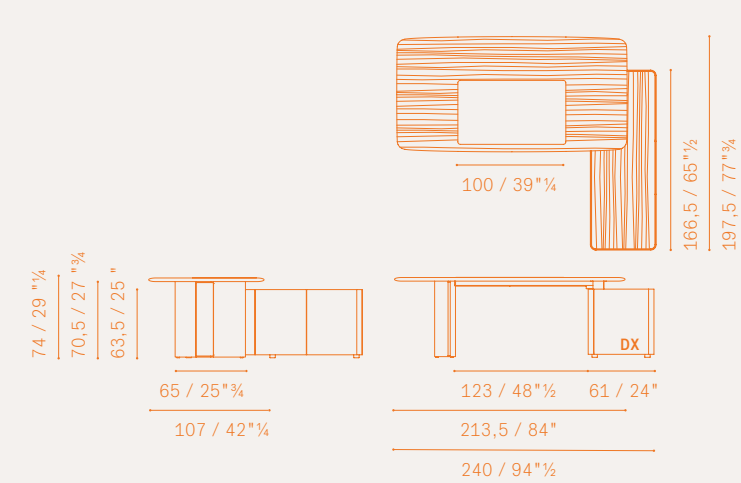

5644711 | D

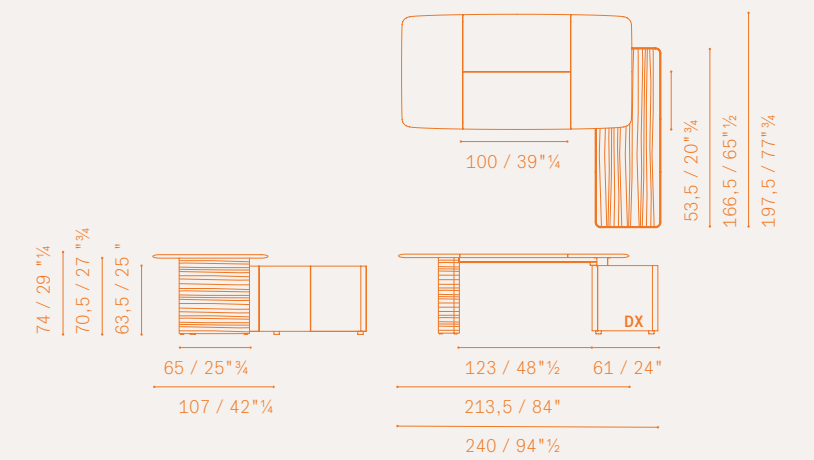

5644711 | E

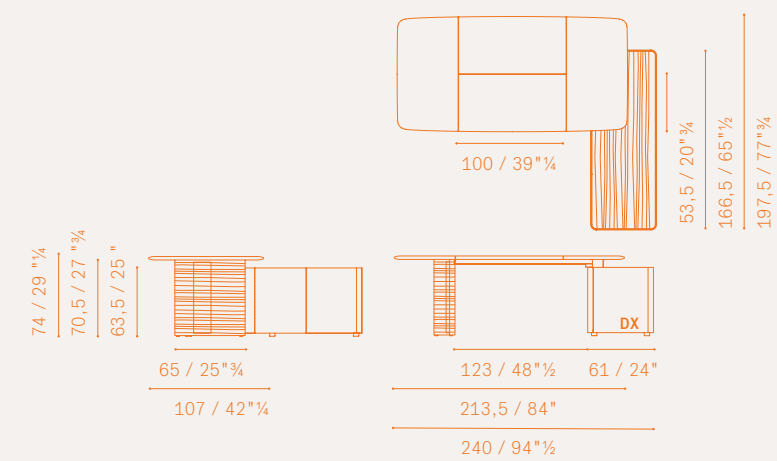

5644711 | F

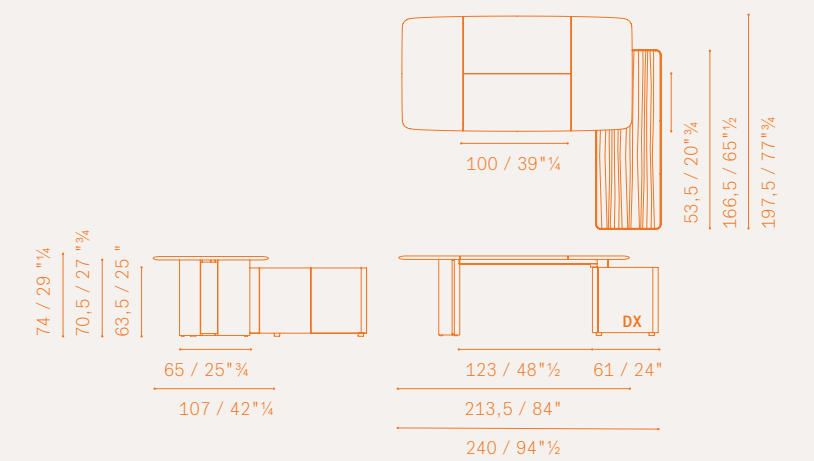

# Trust — Regular Desk 214×107 with storage unit

5644711 | G

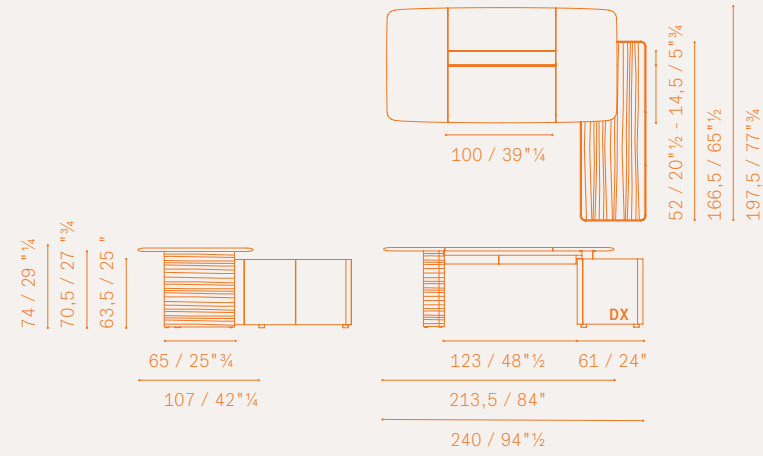

5644711 | H

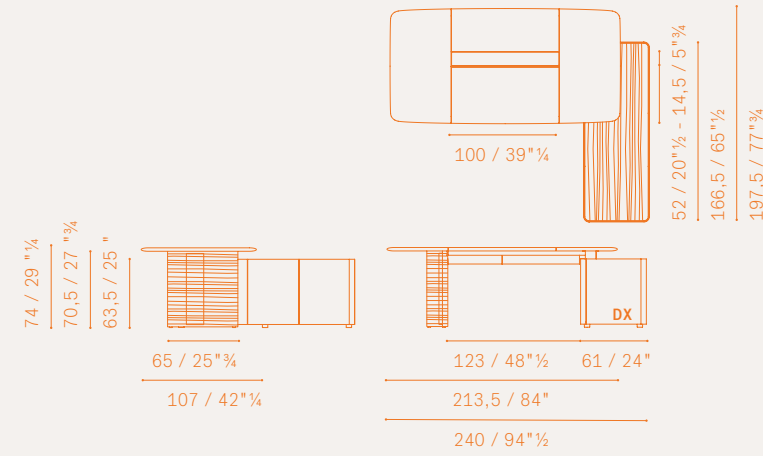

5644711 | I

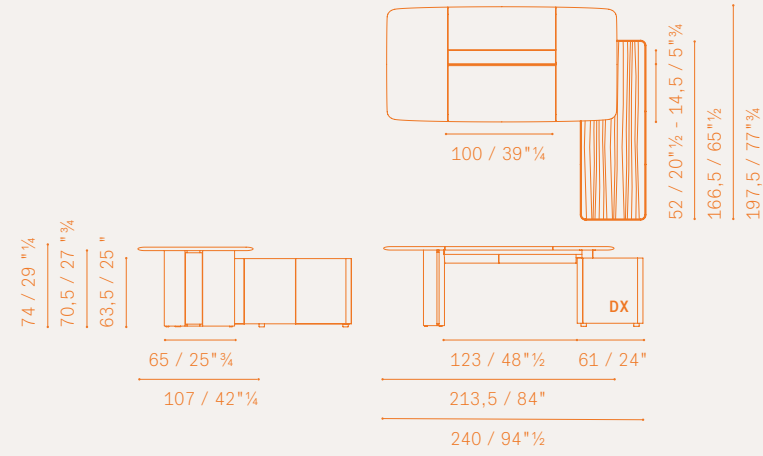

5644711 | J

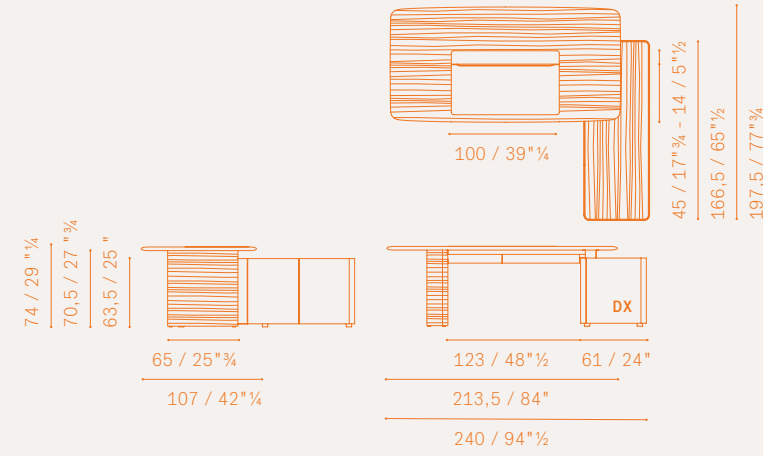

5644711 | K

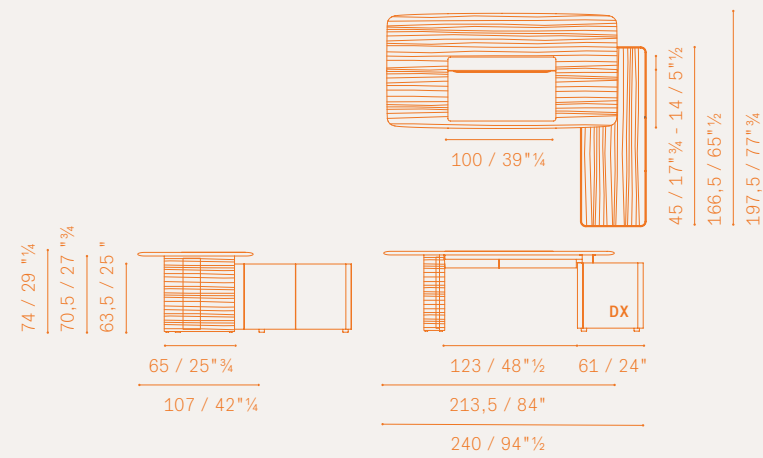

5644711 | L

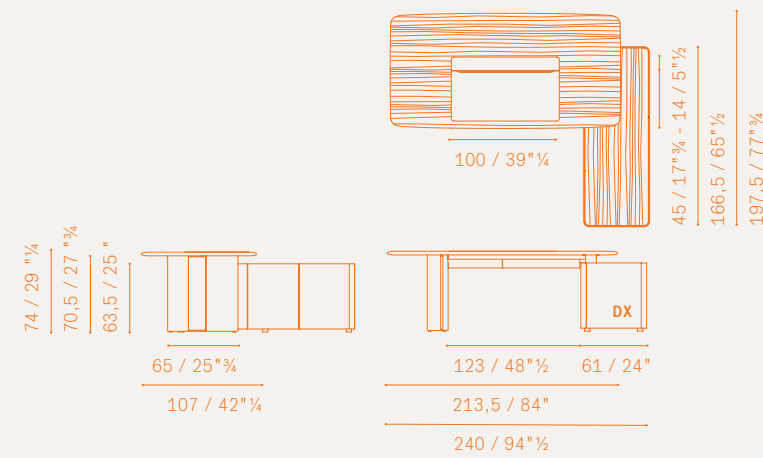

**Please note:**

this catalogue shows only some technical drawings, in order to know all the availabilities please refer to the current price list.

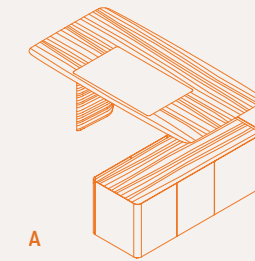

**A**  
Wood top  
Leather working pad  
Wood leg

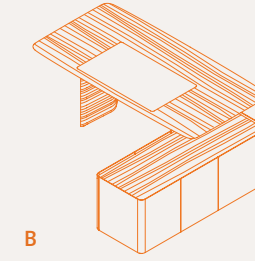

**B**  
Wood top  
Leather working pad  
Wooden leg with cable management area

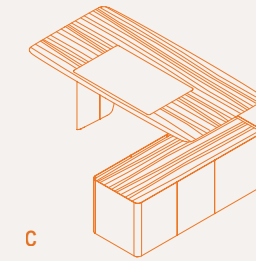

**C**  
Wood top  
Leather working pad  
Leather leg with cable management area

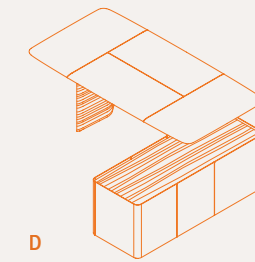

**D**  
Leather top  
Wood leg

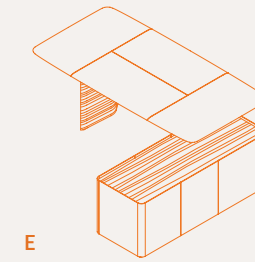

**E**  
Leather top  
Wooden leg with cable management area

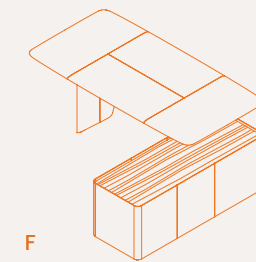

**F**  
Leather top  
Leather leg

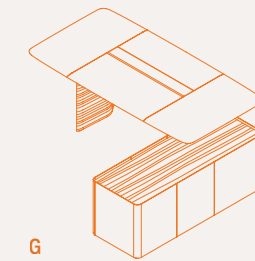

**G**  
Leather top with cable management door  
Wooden leg

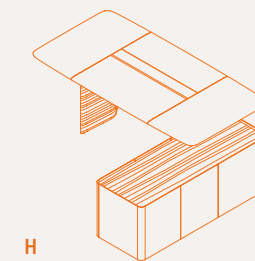

**H**  
Leather top with cable management door  
Wooden leg with cable management area

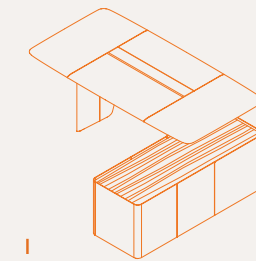

**I**  
Leather top with cable management door  
Leather leg

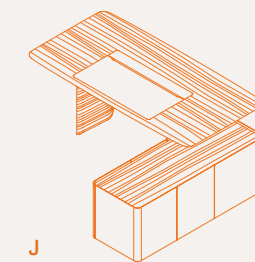

**J**  
Wood top  
Leather working pad with cable management door  
Wooden leg

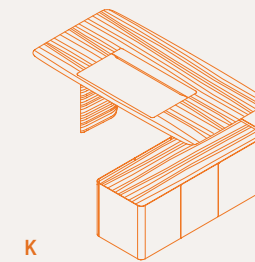

**K**  
Wood top  
Leather working pad with cable management door  
Wooden leg with cable management area

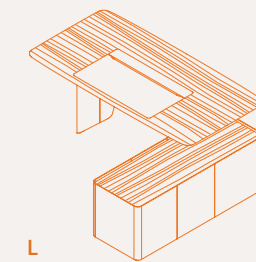

**L**  
Wood top  
Leather working pad with cable management door  
Leather leg





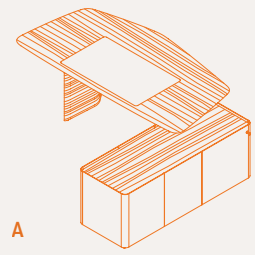

**A**  
Wood top  
Leather working pad  
Wood leg

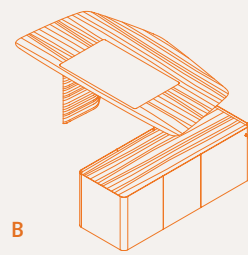

**B**  
Wood top  
Leather working pad  
Wooden leg with cable management area

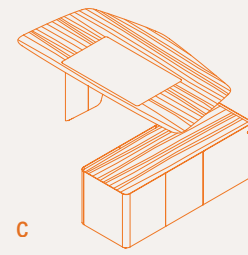

**C**  
Wood top  
Leather working pad  
Leather leg with cable management area

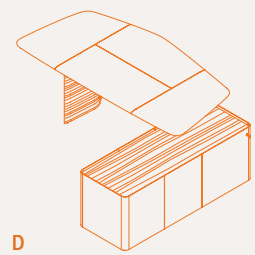

**D**  
Leather top  
Wood leg

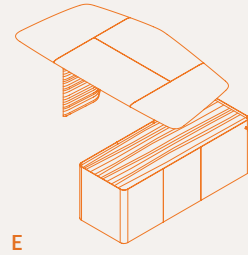

**E**  
Leather top  
Wooden leg with cable management area

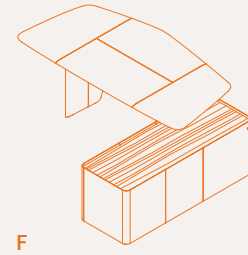

**F**  
Leather top  
Leather leg

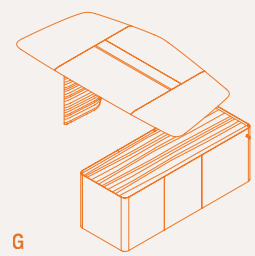

**G**  
Leather top with cable management door  
Wooden leg

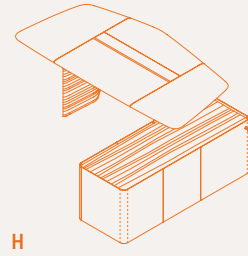

**H**  
Leather top with cable management door  
Wooden leg with cable management area

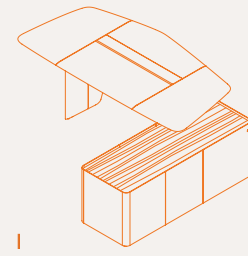

**I**  
Leather top with cable management door  
Leather leg

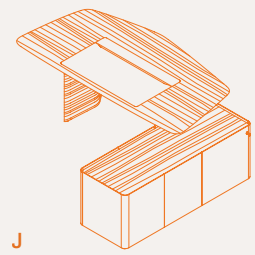

**J**  
Wood top  
Leather working pad with cable management door  
Wooden leg

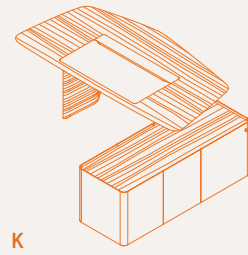

**K**  
Wood top  
Leather working pad with cable management door  
Wooden leg with cable management area

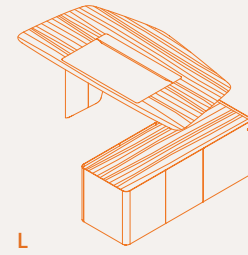

**L**  
Wood top  
Leather working pad with cable management door  
Leather leg

Finishes

Trust — Iconic and Regular desk /  
Iconic and Regular Desk with storage unit

Top

- Natural oak TW
- Medium oak TW
- Pelle Frau® SC
- Saddle Executive

Top in oak TW. Working pad

- Pelle Frau® SC
- Saddle Executive

Cable management door

- with cable management door
- without cable management door

Legs finish

- Natural oak TW
- Medium oak TW
- Pelle Frau® SC
- Saddle Executive

Accessories

- Without accessories
- With modesty panel
- With cable grommet

Storage unit position (in the item with storage unit)

- Right-hand unit
- Left-hand unit

# Trust — Drawer unit / Cabinet

5644761

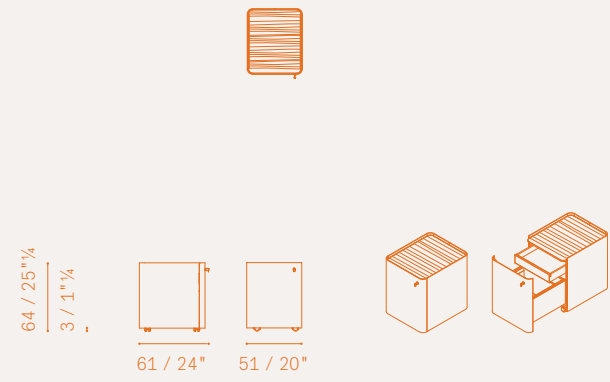

5644781

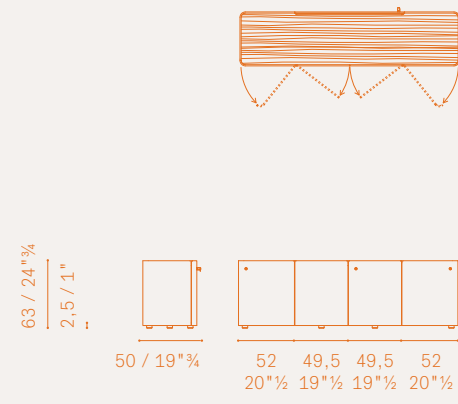

Finishes  
Trust — Drawer unit / Cabinet

- Top
- Natural oak TW
  - Medium oak TW

- Exterior upholstery and drawers
- Pelle Frau® SC
  - Saddle Executive

- Supports (only for Drawer unit)
- Free hard swivel castors
  - Free soft swivel castors

# Trust — Screen / Sectional modules and accessories

5644870

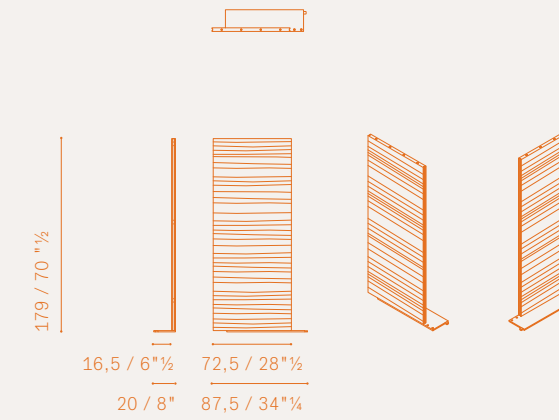

5644871

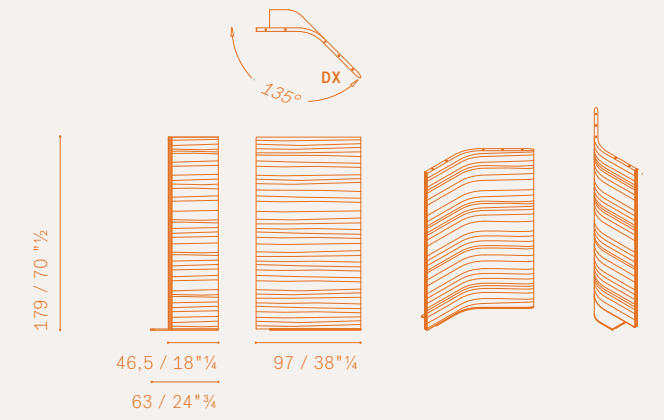

5644871

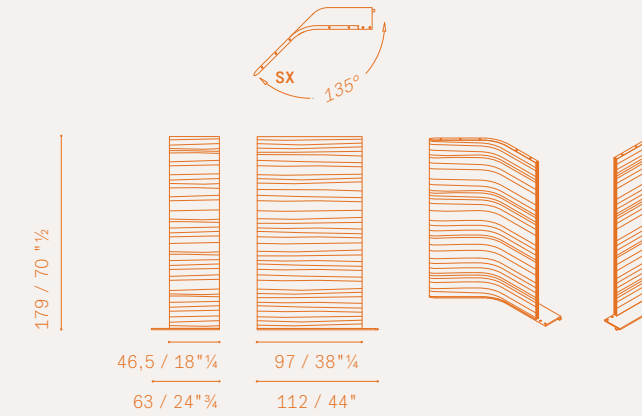

5644872

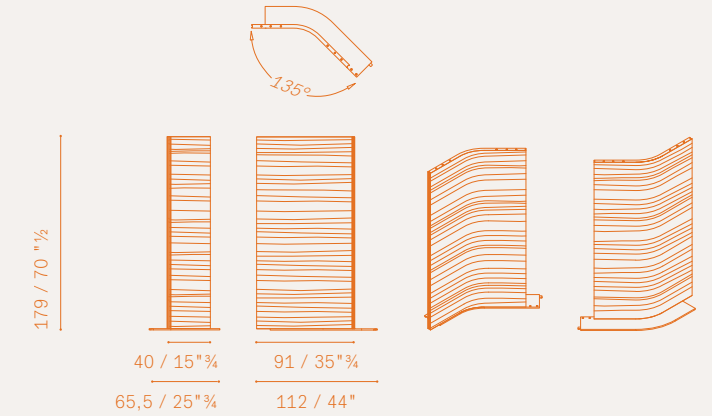

5644880

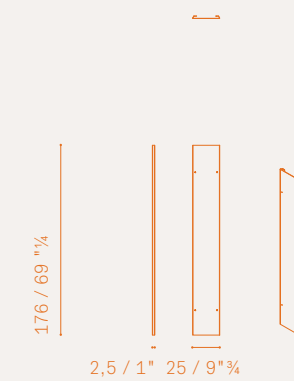

5644881

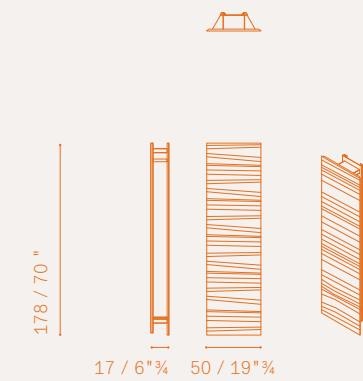

5644860

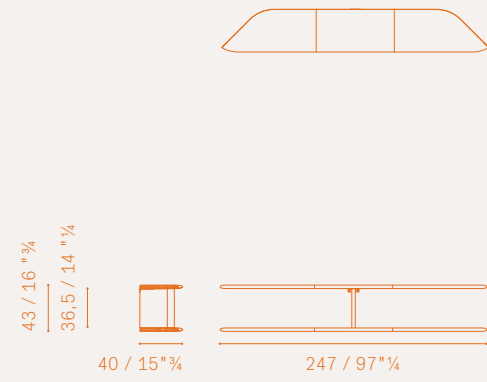

5644861

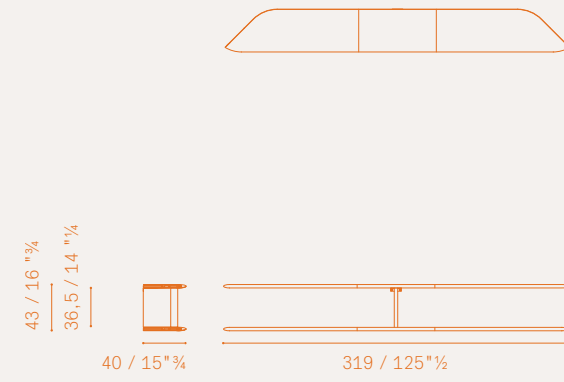

5644862

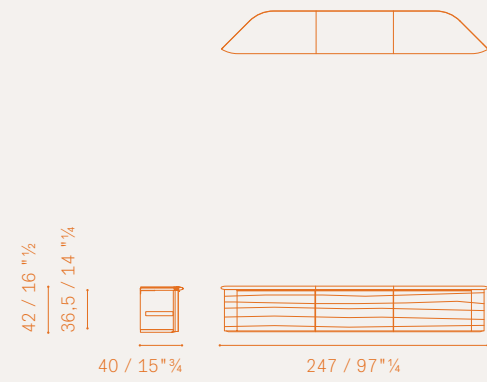

5644863

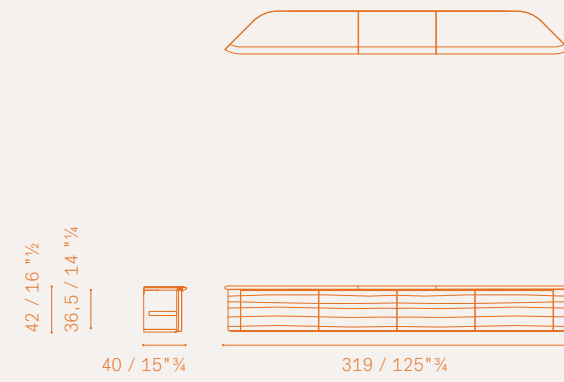

5644864

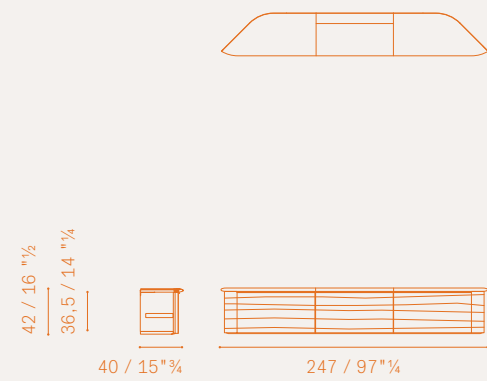

5644865

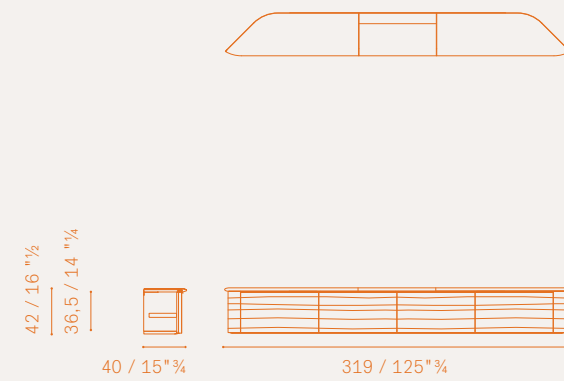

5644867

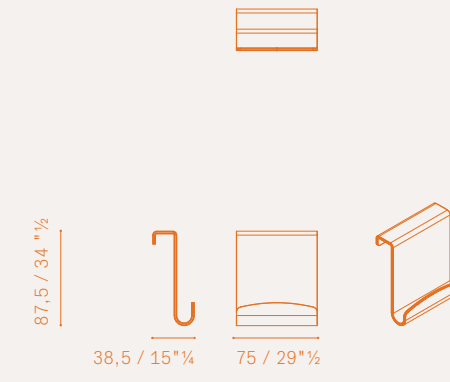

Finishes  
Trust — Screen

**Screen**

Panel finish  
— Natural oak TW  
— Medium oak TW

**Shelves**

Upholstery  
— Pelle Frau® SC  
— Saddle Executive

**Cabinet**

Items  
— cabinet  
— cabinet with cable management door

**Top upholstery**

— Pelle Frau® SC  
— Saddle Executive

**Door finish**

— Natural oak TW  
— Medium oak TW

**Clothes stand hook**

Covering  
— Pelle Frau® SC  
— Saddle Executive



**Configuration 1**  
Screen 3 modules

5644871 SX  
5644870  
5644871 DX

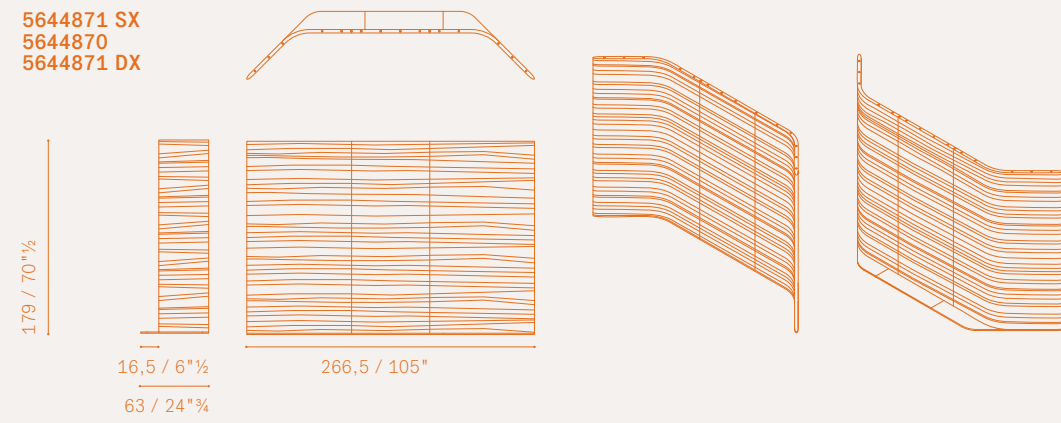

**Please note:**  
these are only some technical drawings. For complete information  
please visit our website [www.poltronafrau.com](http://www.poltronafrau.com) or refer to the current price list.

**Configuration 18**  
Corner screen sx 6 modules with large frontal shelves

5644871 SX  
5644870 (No. 3)  
5644871 DX  
5644872  
5644861

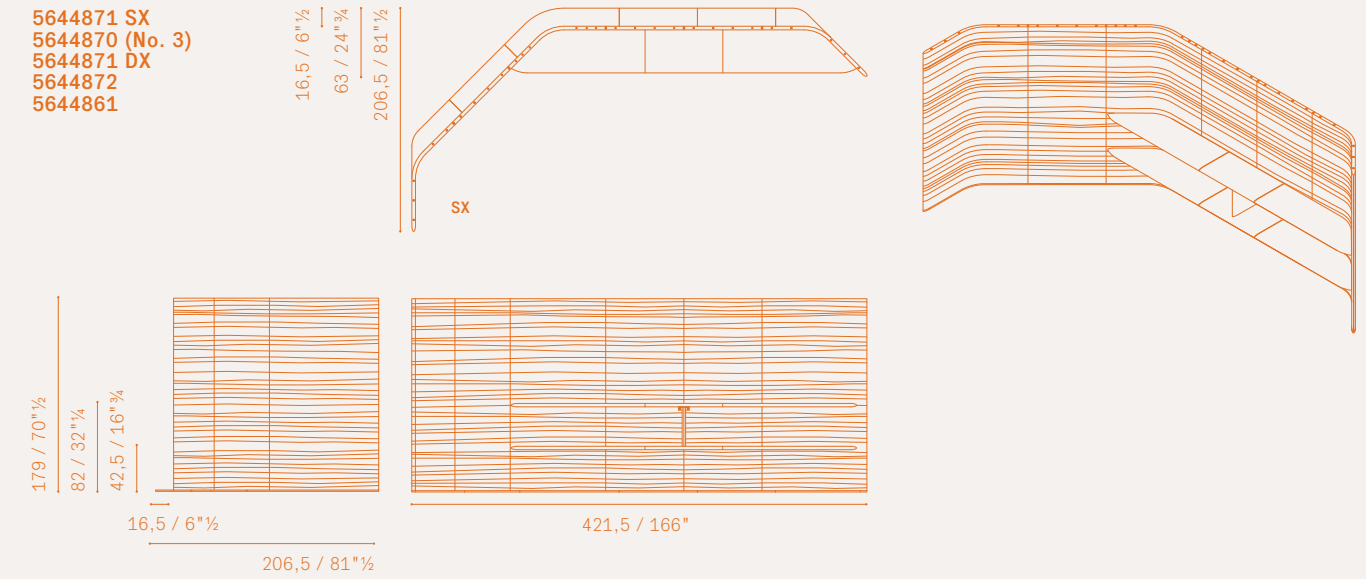

**Configuration 6**  
Screen 4 modules with large shelves

5644871 SX  
5644870 (No. 2)  
5644871 DX  
5644861

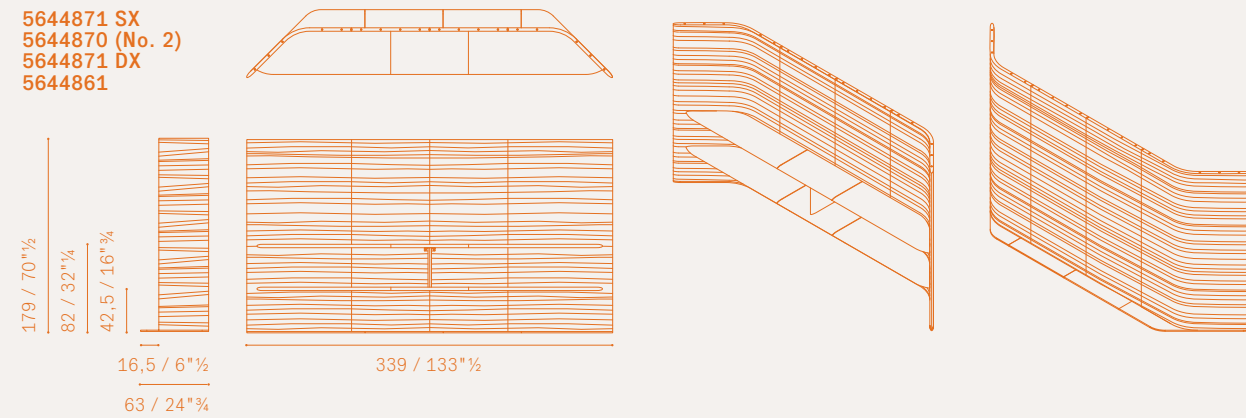

**Configuration 19**  
Corner screen dx 6 modules with large frontal cabinet

5644871 SX  
5644870 (No. 3)  
5644871 DX  
5644872  
5644863

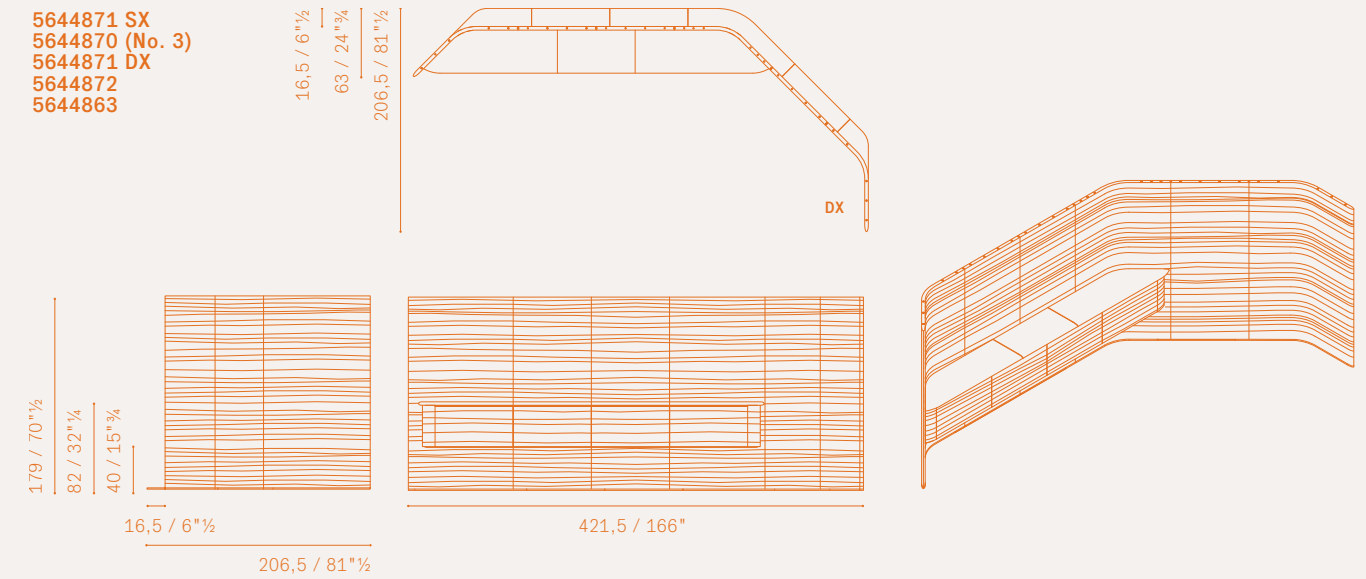



Cercle — 202



Chancellor — 218

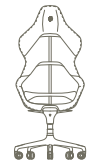

Cockpit — 226

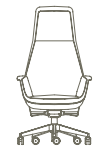

DownTown — 238

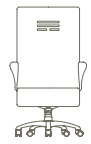

Forum — 248

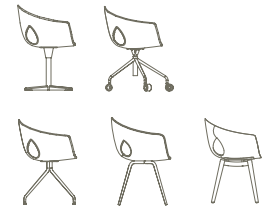

Ginger Ale — 256



Oxford — 268

Office Collection  
Poltrona Frau

Office chairs

Cercle — Chancellor  
Cockpit — DownTown  
Forum — Ginger Ale — Oxford

## Cercle

In un mondo che cambia, la parola condivisione è il nuovo punto di partenza verso un approccio originale agli spazi del lavoro. La serie di sedute da ufficio Cercle già dal nome esemplifica questo concetto.

Cercle in catalano significa infatti “circolo di persone che dialogano fra loro”. Il progetto di Lievore, Altherr, Park è perfettamente coerente con la nuova visione dell'ufficio executive di Poltrona Frau: forme e proposte che vogliono promuovere le relazioni e offrono un design volto a stimolare una modalità lavorativa più adatta ad un manager contemporaneo che opera in spazi aperti, condividendo idee e sommando con gli altri le proprie capacità creative. Nella sedia da ufficio Cercle, lo studio dell'ergonomia è particolarmente

In a changing world, the word ‘sharing’ is a new point of departure for an original approach to the work environment. The series of Cercle office chairs exemplifies this concept starting with its name.

In fact, in Catalan a Cercle is a “circle of people that dialogue with each other”. The project by Lievore, Altherr and Park is perfectly consistent with Poltrona Frau’s new vision of the executive office: forms and ideas that seek to promote relationships and showcase designs that foster working methods more suited to the contemporary manager who works in open spaces, sharing ideas and combining his creative skills with those of his team.

The ergonomics of the Cercle office chair have been studied in particular depth. The syn-

世の中の変化に連れて仕事のためのスペースについて独自のアプローチを考えるなら、シェアリングという言葉からスタートするのが良さそうです。オフィスチェアのシリーズ「Cercle」は名前からしてすでにこのコンセプトの好例と言えるでしょう。

実は「Cercle」とはカタロニア語で「話し合いをする人の輪」という意味なのです。リエボレ、アルテール、パークによるこのプロジェクトは、Poltrona Frauが考える管理オフィス用の新しいイメージにぴったりと沿っています。人間関係を推進し、自らの創造力を結集し、アイデアを共有しながらオープンスペースで働く現代のマネージャーにより適した仕事の仕方を促進するデザインが特徴的な形状と性能。オフィスチェアの「Cercle」では人間工学が特に深く追究されています。シンクロ機構

在不断变化的世界里，“分享”这个词成为新的出发点，思考工作空间的原创视角从此诞生。Cercle办公室座椅系列从名字上便能展现这一概念。

事实上，Cercle在加泰罗尼亚文中的含义是“互相对话的人组成的圈子”。Lievore、Altherr、Park的设计项目与Poltrona Frau的总裁办公室新理念完美契合：其外形与品类以增进关系为主旨，设计目的在于激励一种更加适应开放空间中当代经理人的工作方



↑ ↗ Cercle President, Pelle Frau® SC 28 Seppia / Aluminium in a black finish base  
↑ Detail of the backrest



approfondito. Il meccanismo sincronizzato è integrato alla monoscocca ed è ulteriormente ottimizzato da Poltrona Frau per offrire altissime prestazioni di comfort. La struttura è in poliuretano con inserto metallico. L'imbottitura è in poliuretano espanso a densità differenziata per le zone di maggior comfort e trapunta in ovatta poliestere. Il basamento in alluminio lucido o verniciato nero è

chronised mechanism is integrated in the single shell and further optimised by Poltrona Frau to offer high-quality comfort. The structure is made from polyurethane with metallic insert. The padding is in differentiated-density polyurethane foam for more comfortable areas and polyester wadding quilt. The polished aluminium or black lacquered base has five spokes with the column connected to the cover

が搭載されたモノボディーは、Poltrona Frauによって最適化されて、最高の心地よさを提供します。フレームは金属インサートが入ったポリウレタンです。パディングにはコンフォートゾーンによって密度の異なる発泡ポリウレタンで、ポリエステルパッド製キルト仕上げになっています。ベースは5本スポークタイプの光沢仕上げまたはブラック塗装を施したアルミニウム製で、カバーとの連結用の柱にはガススプリン

式、即分享理念并将自己的创造能力与他人结合。Cercle办公室靠背椅中，对人体力学的研究尤为深入。同步机械装置与整体骨架相结合，经过Poltrona Frau的进一步优化，能够带来绝佳的舒适性能。结构采用聚氨酯，配金属内芯。内部填充具有不同密度的聚氨酯泡沫，为不同区域带来更高舒适度，同时绗缝聚酯棉。五支脚底座采用抛光铝或黑色喷漆铝，通





a cinque razze, con colonna di collegamento al carter attrezzata con molla a gas e verniciata in accordo alla finitura del basamento. L'appoggio è su ruote tipo "W" autofrenanti, morbide o dure. I rivestimenti in Cuoio Saddle Executive e Pelle Frau®, totalmente privi di cuciture, esaltano la bellezza formale della seduta. Cercle può essere rivestita anche completamente in Pelle Frau®, o abbinare la pelle o il cuoio della scocca alla pelle o al tessuto della superficie interna.

equipped with a gas spring and painted to match the finish of the base. The automatic-braking "W" castors can be soft or hard. The Cuoio Saddle Executive and Pelle Frau® leather covers, completely free of stitching, exalt the formal beauty of the seat. Cercle can also be completely upholstered in Pelle Frau® leather or come in a combination of leather or saddle-leather for the structure and leather or fabric for the inside surface.

グが付いており、ベースの仕上げに合わせた塗装が施されています。設置部分には自動ストップ機能が搭載された"W"型タイヤ(やわらかいタイプと固いタイプがあります)が付いています。Cuoio Saddle ExecutiveとPelle Frau®のカバー材は座面のフォーマルな美しさが引き立つように、まったくステッチがないデザインです。「Cercle」はPelle Frau®で全体を上張りしたバージョンと、ボディーのレザーやなめし革を内側表面のレザーやファブリックに合わせたバージョンもご利用いただけます。

过连接支杆与底盘相连，支杆中装备空气弹簧，根据底座所用表面处理进行喷漆。支撑点为"W"型软质或硬质自锁轮。表面覆盖Cuoio Saddle Executive鞣制皮革和Pelle Frau®皮革，完全没有缝线，彰显座椅的外形美感。Cercle也可以完全覆盖Pelle Frau®皮革，或者进行搭配，在骨架上覆盖皮革或鞣制皮革，内表面覆盖皮革或布艺。





↑ ↗ Cercle Executive, Saddle Executive Bourbon with Fabric Kvadrat Re-wool 828 / Polished aluminium base  
↗ Detail of the fabric internal surface





↑ ↗ Cercle Executive, Saddle Executive Bourbon with Fabric Kvadrat Re-wool 828 / Polished aluminium base  
↗ Detail of the lever located under the seat







# Cercle

President / Executive / Managerial / Meeting / Visitor



# Cercle

## Cercle President

5643011

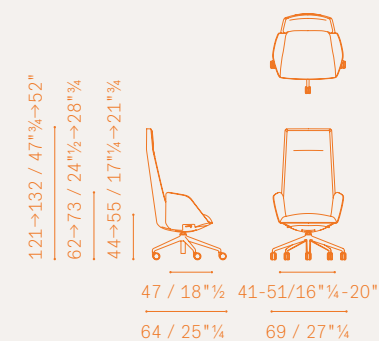

## Cercle Executive

5643021

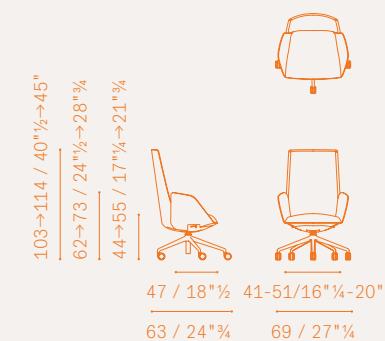

## Cercle Managerial

5643041

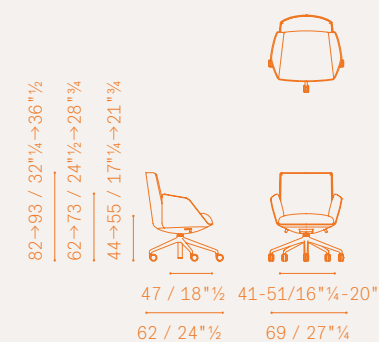

## Cercle Meeting

5643031

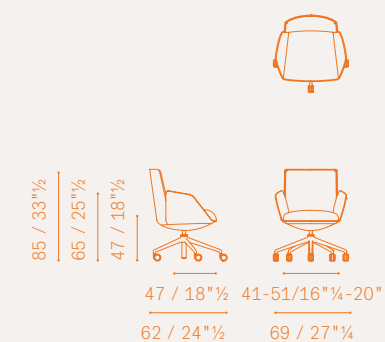

## Cercle Visitor

5643061

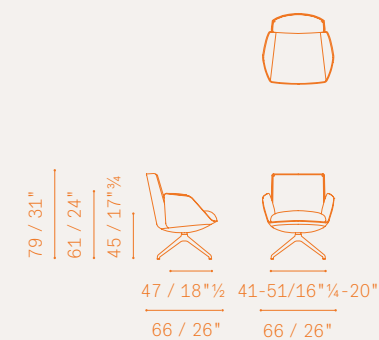

## Cercle Office Chair — Finishes

### Base finishes

- Polished aluminium
- Aluminium in a black finish

### Supports

- Soft, self-braking "W" type castors glides
- Hard, automatic-braking "W" castors

### Castor finish

- chrome-plated
- black

### Upholstery

- ColorSphere® (SC)
- ColorSphere® (SC) / Fabric A
- ColorSphere® (SC) / Fabric B
- ColorSphere® (SC) / Fabric C
- ColorSphere® (SC) / C.O.M
- Saddle Executive / ColorSphere® Frau® (SC)
- Saddle Executive / Fabric A
- Saddle Executive / Fabric B
- Saddle Executive / Fabric C
- Saddle Executive / C.O.M

## Chancellor

## LIEVORE – ALTHERR - MOLINA

Lo studio Lievore Altherr Molina nasce nel 1991 dalla fusione di tre partner: Alberto Lievore, Jeannette Altherr e Manel Molina. Sin dalla sua fondazione si è dedicato al design di prodotto, alla consulenza e alla direzione artistica di varie aziende. Nel corso degli anni lo studio ha avuto numerosi riconoscimenti nazionali e internazionali, tra cui Design Award nazionale spagnolo nel 1999, e ha sviluppato, contemporaneamente, notevoli capacità di insegnamento realizzando seminari e corsi di formazione per nuove figure professionali in diverse università spagnole e altre organizzazioni.

## CONCEPT

L'essenzialità formale di un confortevole abbraccio. Una collezione di sedute dalle sobrie geometrie ed una forte presenza scenica nello spazio di lavoro. I braccioli continui con il piano seduta suggeriscono nuove gestualità e sono concepiti per migliorare il livello di comfort e relax.

## LIEVORE – ALTHERR - MOLINA

Lievore Altherr Molina was created in 1991 by the merging of its three partners: Alberto Lievore, Jeannette Altherr and Manel Molina. Since its foundation, the studio has been devoted to product design, consulting and the art direction of various companies. Throughout the years the studio has been awarded with many national and international prizes, including Spain's National Design Award in 1999. Simultaneously, it has developed an intense teaching practice, giving seminars and training courses to new professionals at various Spanish universities and other organizations.

## CONCEPT

The formal purity of a comfortable embrace. A collection of sober, geometrical chairs with a strong scenic presence in the workplace. The arms that continue from the seat provide a new expression and are designed to improve comfort levels and enhance relaxation time.

## リエヴォレ - アルテール - モリーナ

Lievore Altherr Molina リエヴォレ - アルテール - モリーナ・スタジオは 1991 年にアルベルト・リエヴォレ、ジャネット・アルテール、マネル・モリーナ、3 名の合同で創設された。当初から、プロダクト・デザイン、様々な企業のコンサルティングやアーティスティック・ダイレクションを手掛けた。以来、同スタジオは 1999 年のスペイン・ナショナル・デザイン・アワードをはじめ、国内外の数多くの賞を受賞して来た。同時に、スペインの大学やその他の団体で新進のプロを育成するセミナーや養成講座を通して、優れた指導力も発揮している。

## コンセプト

快適な掛け心地を生み出す無駄の無いフォルム。すっきりとしたデザインが職場で存在感を発揮するアームチェアのコレクション。座部から続く肘掛により、新しい座り方が暗示され、コンフォート感やリラククス感がいっそう高まる。

## LIEVORE – ALTHERR - MOLINA

Lievore Altherr Molina 创作于 1991 年，是根据三位合作伙伴的名字命名，他们分别是 Alberto Lievore, Jeannette Altherr 和 Manel Molina。成立以来，这家事务所便专注于产品设计，并为众多公司进行艺术指导及顾问工作。经年累月，这家事务所囊括了包括 1999 年西班牙国家设计奖在内的许多国内国外的大奖。与此同时，他们还开发了一套有针对性的教学内容，为西班牙大学或专业机构的新晋专业从业者提供讲座和培训课程。

## 理念

这是一个纯正的舒适怀抱。一把造型朴素，几何感极强的单椅，放置在工作区域有很强大的气场。扶手的造型是由座位延伸而来，提供了一种全新的设计表达方式，将舒适感提升到新的境界，提高休闲时间的质量。



La base d'appoggio, disponibile in alluminio verniciato grigio scuro o in alluminio lucido, è composta da 5 razze attrezzate con ruote tipo "W" auto-frenanti morbide o scivoli girevoli. La versione Visitor ha una base d'appoggio a 4 razze sempre fornita con scivoli girevoli.

In the President, Executive, Managerial and Meeting versions, the five-spoke resting base, which is available either in polished aluminium or a dark grey finish, is fitted with soft, self-braking "W" type wheels or with swivel castors. The Visitor version has a 4-spoke base with swivel glides.

座部を支える支柱はダークグレー塗装仕上げ又は光沢仕上げのアルミ製、支柱から脚が5本、車輪の表面がソフト・タイプのセルフ・ブレーキ機能付"W"型キャスター、又は回転式グライダー・キャスター付。Visitorモデルは支柱から脚が4本、回転式グライダー・キャスター付。

在总裁椅、行政椅、经理椅及会议椅款型中，五轮底座支架可选择抛光或深灰色饰面铝金属，并配备柔软的可锁定"W"型脚轮或万向轮。访客椅的底座为四轮支架，并配备万向轮。







Regolabili in altezza e rotabili su stesse, le versioni President, Executive e Managerial sono dotate di un meccanismo di oscillazione "Sincron" di schienale e sedile che può assumere una serie continua di 5 posizioni fino a diventare una vera e propria chaise-longue. Il rivestimento in Pelle Frau® del ColorSphere® può essere esteso anche al carter di copertura del movimento "Sincron". La versione Meeting può ruotare su se stessa mentre la Visitor è dotata di un meccanismo di rotazione con ritorno nella posizione di partenza.

The President, Executive and Managerial versions are height adjustable, rotate, and are fitted with a "Sincron" turning mechanism for seat and backrest, that boasts a continual series of 5 different positions ranging into an actual chaise-longue. Upholstery is in Pelle Frau® leather from the ColorSphere®. A thrust-bearing mechanism allows Meeting to rotate around its axis. Chancellor Visitor is fitted with an automatic return rotation mechanism.

高さ調節可能で回転式。President, Executive、Managerial のモデルには、背部と座部に "Sincron" シンクロンという段階式のリクライニング装置が付いており、シェーズ・ロングさながらの角度まで傾ける事ができる。Pelle Frau® del ColorSphere® カラーシステムのベッレ・フラウ®の革張りで "Sincron" シンクロン装置のクランクケースのカバーまで覆う事も可能。Meeting モデルは回転式、Visitor モデルはオートリターン機能付。

总裁椅、行政椅以及经理椅的款型均可以调节座高，并且可以旋转。“同步”旋转机械装置可以使单椅的座位以及靠背轻松配合人体的运动，并可以连续5档调节位置，直至变成一张真正的长榻。套面软包为从 ColorSphere® 色彩系统中精选的 Pelle Frau® 皮革，同时也可以包裹“同步”旋转机械装置的金属件。由于安装了推力轴承机械装置，使得该款办公扶手椅可以围绕自身轴线原地转动。Chancellor 访客椅配备了自动回转的装置。

# Chancellor President / Executive / Managerial / Meeting / Visitor



## Chancellor

### Chancellor President

5503011

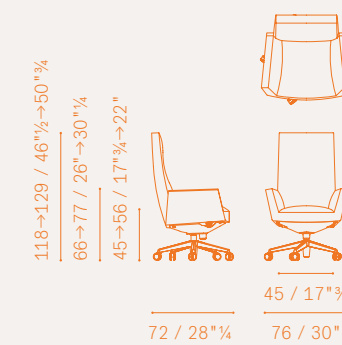

### Chancellor Executive

5503021

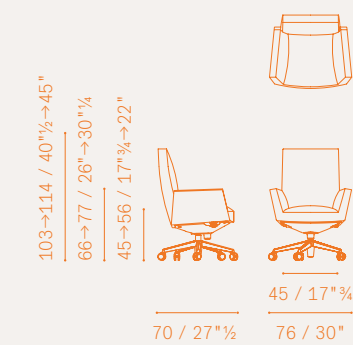

### Chancellor Managerial

5503031

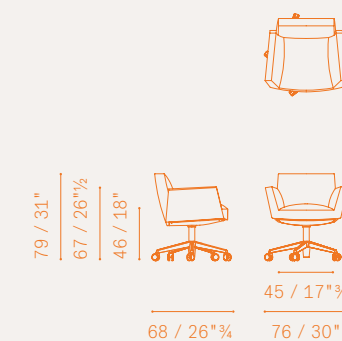

### Chancellor Meeting

5503041

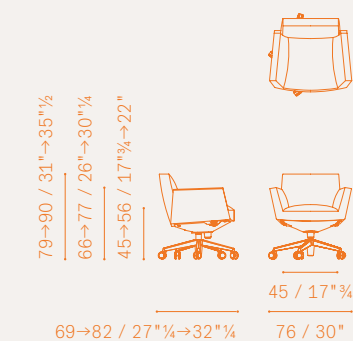

### Chancellor Visitor

5503061

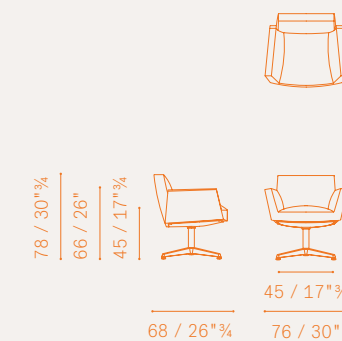

### Chancellor — Finishings

Upholstery  
— Pelle Frau® leather from the ColorSphere®

Base  
— Aluminium in a dark grey finish  
— Polished aluminium

Stitching  
— in matching tones thread  
— with a contrast thread

Supports  
— Soft, self-braking "W" type castors  
— Swivel glides (2 cm lower height)

# Ferrari Design Centre Poltrona Frau

## Cockpit

Non una seduta automotive e nemmeno di puro arredo e design. Un ibrido contemporaneo dove si incontrano due marchi, due immaginazioni, due filosofie industriali per celebrare i 70 anni della Casa di Maranello. Un nuovo oggetto che offre la traduzione esatta di un sogno in realtà. Una seduta da ufficio che del sedile del pilota capta le valenze emotive, la sensazione di velocità e slancio, la passione della corsa. E riesce a trasmettere la gratificante percezione di come movimenti e posture siano assecondati da schienale e seduta. Know-how automobilistico e cultura dell'abitare si fondono tra loro. Con-

Neither a car seat nor a pure piece of furniture or design. It is a contemporary hybrid that brings together two brands, two imaginations, two industrial philosophies to celebrate the 70th anniversary of the Maranello carmaker. A new object that perfectly translates a dream into reality. This is an office chair that captures the excitement, speed and dynamism of the driver's seat, as well as the passion for racing. And that transmits a pleasant sensation of how the backrest and seat support movements and posture. A blend of automotive know-how and the culture of living.

ポルトローナ・フラウは多岐に亘るコレクションのカタログを家具の分野別にご用意していますが、基本となるフィロソフィーは一貫しています。日々の暮らしの中のどの時間帯でも、快適にお過ごしいただけるよう、洗練された心地よい環境を生み出す事を目指しているのです。高級で、精度の高いお住まいを造り出すために素材を厳選し、ディティールにこだ

わって、高性能のコンフォートを提供

するポルトローナ・フラウの住環境にその根本となる精神が見てとれます。イタリアの家具作りの比類なき伝統を踏襲するポルトローナ・フラウは使用する素材の質の高さ、作りの丁寧さこそが製品のハイグレードな仕

Poltrona Frau 高度多元化。不同的产品目录介绍了不同的功能，并共享相同的品牌理念。那就是，创造一个完美的空间，给使用者无论何时都能享受优雅和舒适。Poltrona Frau 的办公家具精髓得益于对家用家具炉火纯青的诠释，对舒适高雅的极致追求使其非常挑剔用料和细节。Poltrona Frau 坚信，真正的意大利处世哲学，卓越的表达不外乎其对材料和生产工艺



↑ Cockpit President and Executive, Scuderia 2 version  
↗ Cockpit Executive and President, Scuderia 1 version

Poltrone Ufficio — Cockpit

Office Armchairs — Cockpit

オフィス用アームチェア — Cockpit

领导体系 — Cockpit





cepita e disegnata dal team di design diretto da Flavio Manzoni che ha progettato le recenti vetture Ferrari (tra cui la LaFerrari Aperta, la GTC4Lusso e la 812 Superfast), la sua linea iconica si slancia nello spazio avvolgendo il corpo. Una struttura tridimensionale, connubio tra bellezza estetica e perfezione ergonomica applicata alle sedute per gli spazi di lavoro.

Conceived and designed by the design team directed by Flavio Manzoni, which designed the recent Ferrari models (including the LaFerrari Aperta, the GTC4Lusso and the 812 Superfast), its iconic profile launches itself into the space enveloping its body. A 3D structure, an amalgam of aesthetic beauty and ergonomic perfection applied to seats for workspaces.

↑ Cockpit President Scuderia 1 version  
 ↗ Detail of the sophisticated mechanism developed for Cockpit

す。ご自宅でポルトローナ・フラウのアームチェア、シェーズロング、ソファの掛け心地や肌触りの良さに慣れてしまうと、職場でレベルの低い“住環境”を受け入れるのは難しいものです。自然な流れとして、100年を超える歴史を経た今、ポルトローナ・フラウから“L'Ufficio” ザ・オフィスのコレクションが誕生しました。

的精益求精。任何已经习惯于 Poltrona Frau 家用家具无与伦比的舒适坐感和品质的人都会很难接受在工作中有不一致的办公体验。Poltrona Frau 是成功人士之选，在品牌 100 多年的发展历程中于 90 年代开发出办公系列家具。





↑ Detail of the sophisticated mechanism developed for Cockpit  
➤ Cockpit President, Scuderia 1 version

Poltrone Ufficio — Cockpit

Office Armchairs — Cockpit

オフィス用アームチェア — Cockpit

领导体系 — Cockpit



↑ Cockpit President, Inedita version, upholstery in Pelle Frau® SC 53 Creta leather



Il risultato del nuovo incontro fra due eccellenze italiane. Poltrona Frau riveste da sempre gli interni delle vetture Ferrari e ora affronta una nuova sfida di estrema complessità. L'azienda di Tolentino dedica al progetto l'alta artigianalità maturata in oltre cento anni di storia e l'innovazione tecnica attraverso cui ridefinisce di continuo la propria tradizione.

The result of a new meeting between two leading Italian companies. Poltrona Frau has long since upholstered the interiors of Ferrari cars and now takes on a new highly complex challenge. The Tolentino-based company dedicates the consummate craftsmanship that it has acquired in over 100 years in the business and its technical innovation, through which it continuously redefines its tradition, to the project.

他のコレクションと同様に快適な掛け心地、細部の完成度の高さ、上質な素材をお約束し、厳選されたレザー、質の高いメタル類による高級仕上げ、高貴な大理石や石材を組合せる事により、高級感溢れるすっきりとしたラインを描きだします。仕上げや組合せの選択肢は非常に幅広く、カスタマイズの楽しみは限り無く広がります。ご自宅でポルトローナ・フラウの比類無い住環境に慣れた方に、オフィスでもその素晴らしい環境を再現していただけるのです。特に、Pelle Frau® ペッレ・フラウ® を使用した革張りは質の高さと耐久性をお約束し、エグゼクティブのオフィスに類を見ない風格を醸し出します。

朝九晚五の办公室生活，由于 Poltrona Frau 的细致体贴使上班变得具有满足感；与起居生活一样同样完美的细节，是通过精心挑选的皮革，精致的木材，简约的结构，珍贵的大理石台面，以及一系列细节装饰来表达的，体现高级定制的无限可能。Poltrona Frau 将炉火纯青的 Pelle Frau® 皮革娴熟运用于高级经理人办公系列，将最高品质的皮革沿用至办公体验，给予职场精英无微不至的关怀。

# Cockpit President / Executive



# Cockpit

**Cockpit** — President with or without central strip

5616011

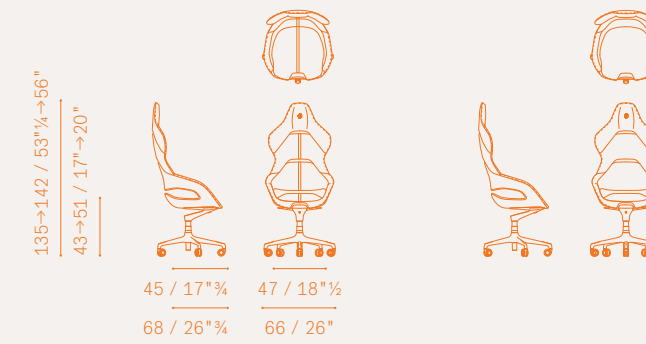

**Cockpit** — Executive with or without central strip

5616021

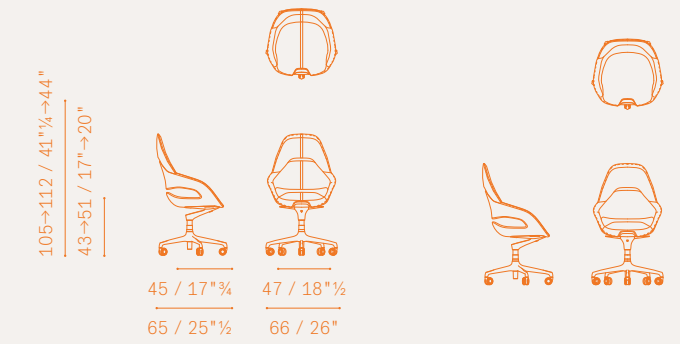

**Cockpit** — Logo Ferrari

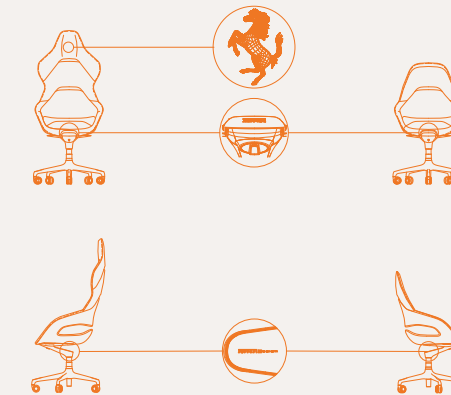

Breakdown of versions

### SCUDERIA 1

Upholstery — Pelle Frau® SC 20 Inchiostro

Central strip — Pelle Frau® SC 127 Siam

Shell — Carbon fiber

Base — Polished aluminium

Stitching — Contrasting red thread

### SCUDERIA 2

Upholstery — Pelle Frau® SC 127 Siam leather

Shell — Carbon fiber

Base — Grigio Corsa

Stitching — Tone-on-tone

### INEDITA

Upholstery — Pelle Frau® SC 53 Creta leather

Shell — Carbon fiber

Base — Polished aluminium

Stitching — Tone-on-tone



# Jean-Marie Massaud

## DownTown

### JEAN-MARIE MASSAUD

Laureato all'ENSCI nel 1990, Jean-Marie Massaud è fin da subito alla ricerca di sintesi, riduzione e leggerezza. Affronta i diversi aspetti del design: dai mobili ai prodotti industriali, alle attrezzature. Nel 2000, crea lo Studio Massaud ed estende la sua attività all'architettura e alle strategie di sviluppo. Ponendo l'uomo ed il suo ambiente naturale al cuore delle sue creazioni, questo ideatore senza limiti adotta un modo di procedere impegnato e politico e si sforza di trasformare ogni progetto in un'esperienza di vita e in uno scenario economico che riconcilia desiderio e responsabilità.

### CONCEPT

Competente, elegante, senza tempo. DownTown è la poltrona da lavoro dedicata a "decision-makers" esigenti che ricercano comfort e eleganza raffinata. Una seduta tecnica che si rivela una silhouette, fatta a mano dagli artigiani di Poltrona Frau come garanzia di alta qualità. Molto più di una bella scultura, DownTown è una creazione sensuale e distintiva di Jean-Marie Massaud.

### JEAN-MARIE MASSAUD

Jean-Marie Massaud graduated from ENSCI (the French national school for advanced studies in design) in 1990 and from the very outset he has sought synthesis, essentiality and lightness. He has handled all aspects of design, from furniture to industrial products and equipment. In 2000, he founded Studio Massaud and expanded his expertise to architecture and brand development. By placing humanity and the natural environment at the heart of his creations, this free-thinking designer adopts an engaged and political approach, striving to make every project into a life experience and to do so within an economic framework that reconciles desire and responsibility.

### CONCEPT

Proficient, elegant, and timeless. DownTown is a desk armchair specially dedicated to demanding decision-makers who seek comfort and refined elegance. A technical seat that looks like a silhouette; handcrafted by Poltrona Frau as a guarantee of the highest quality. More than a beautiful sculpture, DownTown is a sensual and distinctive creation by Jean-Marie Massaud.

### ジャン・マリー・マッソー

1990年にENSCIを卒業してすぐに、Jean-Marie Massaudは、合成と縮小そして軽さの研究を始め、家具から工業製品や機材におけるまで、デザインの(多様な側面)多面性の考察を行う。2000年には、Studio Massaud (マッソー・スタジオ)を設立し、建築や開発計画にまで活動の拡大。創造の中心に人間と自然環境というテーマを想定し、その限界を持たない考案者は積極的かつ政治的な工程を進める方法を選びつつ、あらゆるプロジェクトを人生の経験として、また欲望と責任感を折衷する経済的なシナリオとして、形を変える努力をしている。

### コンセプト

卓越していて、優雅で、時間効果なしには。DownTownは、快適性と洗練された優雅さを求める、要求の多い“decision-makers” デジジョンマーカーのために仕事用アームチェアです。技術的に座ってもまるでシルエットの様で、職人の手作業手作りから生まれる Poltrona Frau (ポルトローナ・フラウ)の品質の高さを証明しています。DownTownは、美しい彫刻以上のもの、Jean-Marie Massaudによる官能的で比類のない被造創造的物なのです。

### 让·马利·马沙德

让·马利·马沙德 1990年毕业于 ENSCI (法国高级设计学校) 后，立即致力于综合化、精简化和轻巧化的研究之中。他的设计涉及各个领域：从家具到工业产品，再到设备。2000年创建了马沙德事务所并拓展了其建筑及品牌拓展的业务。以人和自然环境为创意的核心，设计师采取合理的方式将每个项目转变为人生的体验，并在理想的框架下调和需求和责任。

### 理念

干练、优雅、经久耐用。DownTown 是专为寻求舒适、典雅、细腻的决策者而设计的办公椅。专业的办公椅看起来像一件艺术品，由 Poltrona Frau 的工匠手工制作，是高品质的保证。但又不仅仅作为一个艺术品 DownTown 也是让·马利·马沙德 Jean-Marie Massaud 的一个情感上的独特创造。



Regolabili in altezza e rotabili su se stesse, le versioni President, Executive e Managerial sono dotate di un meccanismo di oscillazione "Synchron" di schienale e sedile che permette alla poltrona di seguire con estrema facilità l'andamento del corpo, con possibilità di blocco in 4 posizioni. La versione Meeting può ruotare su se stessa mentre la Visitor è dotata di un meccanismo di rotazione con ritorno nella posizione di partenza.

The President, Executive and Managerial versions are height adjustable and can rotate. The "Synchron" turning mechanism for the seat and backrest allows the armchair to easily accompany the body's movements and allows it to be locked into 4 different positions. DownTown Meeting can rotate around its axis. DownTown Visitor is fitted with an automatic return rotation mechanism.

高さ調節可能で、回転式。President、Executive、Managerial のモデルは背部と座部の角度を4段階に調節できる "Synchron" シンクロンというリクライニング装置付きで、掛け心地は快適。Meeting モデルは回転式、Visitorモデルはオートリターン機能付。

总裁椅、行政椅以及经理椅的款型均可以调节座高，并且可以旋转。“同步”旋转机械装置可以使单椅的座位以及靠背轻松配合人体的运动，并可以在4个不同位置上进行锁定。DownTown 会议系列办公扶手椅围绕自身轴线原地转动。DownTown 访客椅配备了自动回转的装置。





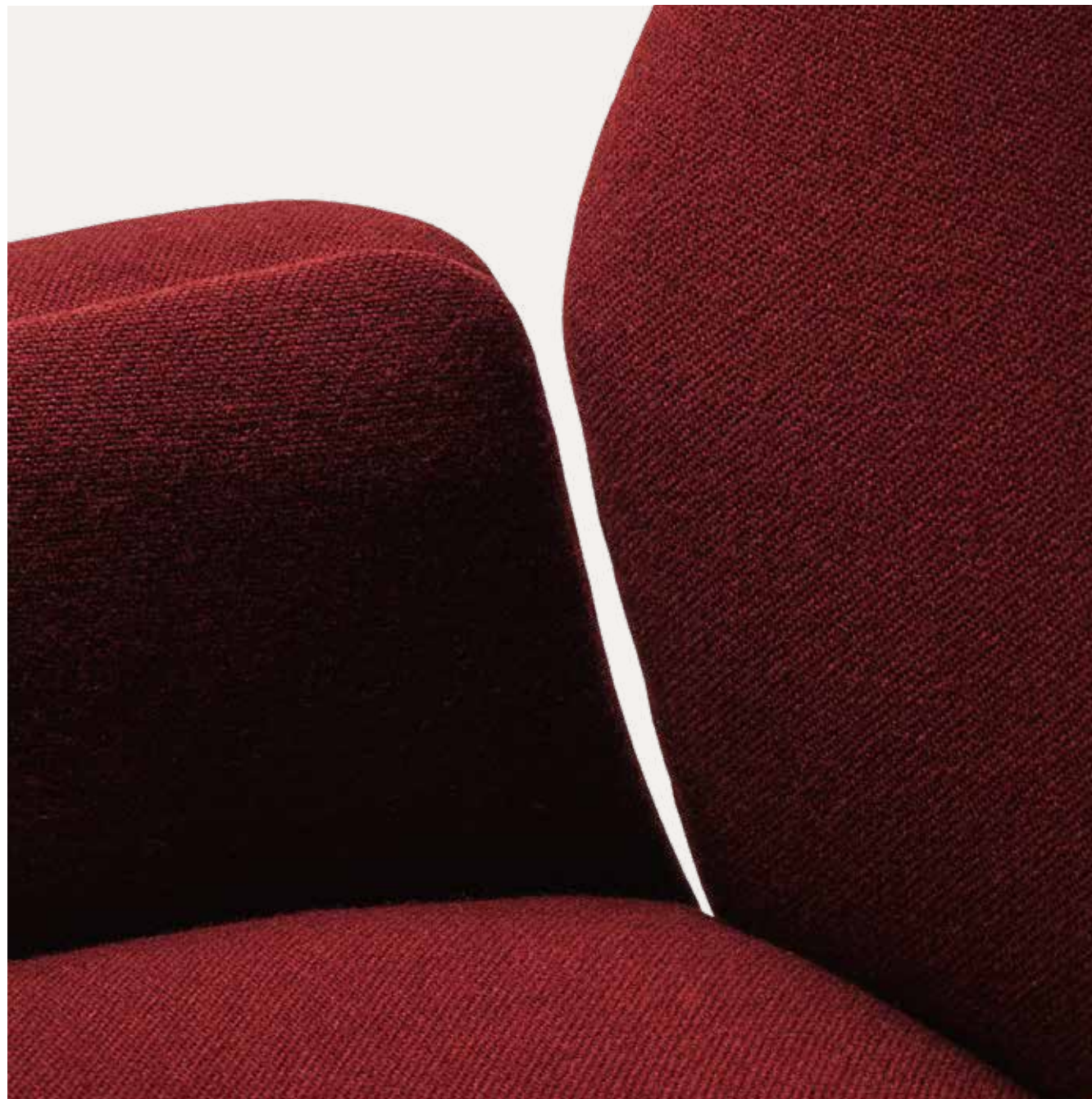

Si ampliano anche i rivestimenti che prevedono la possibilità di ricoprire tutte le poltrone della collezione con tessuti specificati dal cliente, in aggiunta alla Pelle Frau® del ColorSphere®.

There are more upholstery options and all the armchairs in the collection can now be covered with the customer's own fabrics, as well as with Pelle Frau® leather from the ColorSphere®.

カバー材の選択肢も広がり、ColorSphere®の Pelle Frau® に加え、コレクション全てのアームチェアをお客様が指定する生地のカバー材でコーティングすることが可能になりました。

表面装潢也更加丰富，除了 Pelle Frau® ColorSphere® 之外，还可以使用客户指定布艺装饰该系列所有扶手椅。





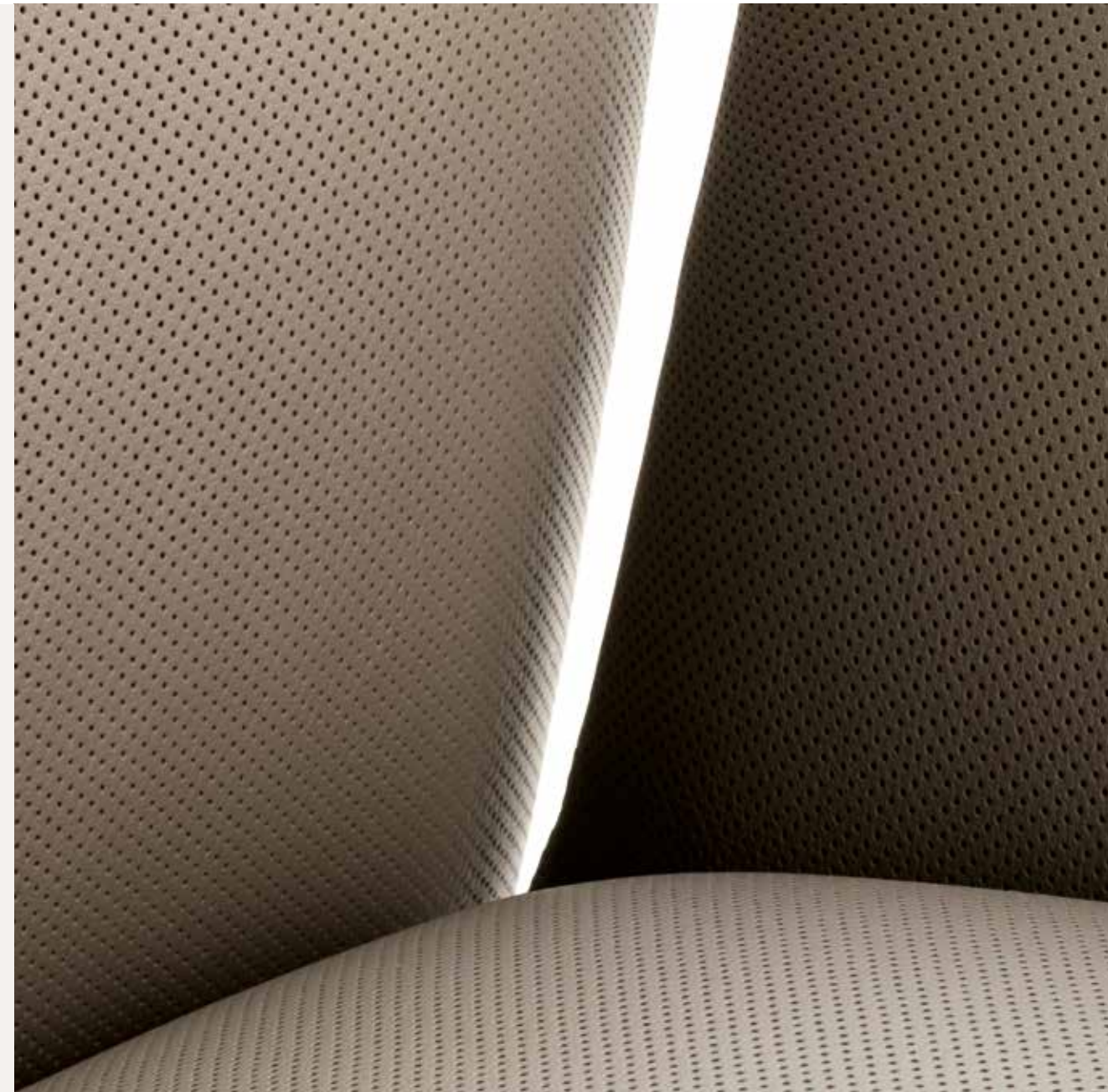

Il rivestimento, impreziosito con cuciture tono su tono o a contrasto, è in Pelle Frau® del ColorSphere®, anche nella versione con microforatura sulla superficie interna della seduta di schienale, braccioli e cuscino. Disponibile anche la versione in tessuto. La base d'appoggio, in alluminio lucido o verniciato nero, è composta da 5 razze attrezzate con ruote tipo "W" piroettanti autofrenanti morbide o scivoli. La versione Visitor ha un basamento a 4 razze con scivoli girevoli.

The upholstery, embellished with tone-on-tone or contrast stitching, is made with Pelle Frau® SC leather, also in a version with micro-perforations on the inner surface of the backrest, armrests and cushion. Also available in the fabric version. The five-spoke resting base, available in either polished aluminium or with a black finish, is fitted with soft, self-blocking "W" type wheels or swivel glides. The Visitor version has a 4-spoke base with swivel glides.

革張りには Pelle Frau® ColorSphere® カラーシステムのベッレ・フラウ®を使い、トーン・オン・トーン又はコントラスト・カラーのステッチで高級感を際立たせる。座部、背部、肘掛、クッションの身体に接する側の面に微小なバンチングが施された革張りもある。光沢仕上げ又はブラック塗装仕上げのアルミ製支柱から脚が5本、車輪表面がソフト・タイプのオートブレーキ機能付 "W" 型回転式キャスター付、又はグライダー・キャスター付。Visitor モデルは支柱から脚が4本、回転式グライダー・キャスター付。

软包的套面装饰有褶边多色调车线或对比车线，并从 ColorSphere® 色彩系统中精选的 Pelle Frau® 皮革，还可以选择在靠背、扶手以及靠垫的内侧套面开小透气孔的款式。五轮底座支架可选择抛光或黑色饰面铝金属，并配备柔软的可锁定 "W" 型脚轮或万向轮。访客椅的底座为四轮支架，并配备万向轮。



# DownTown President / Executive / Managerial / Meeting / Visitor



# DownTown

## DownTown President — Castors or glides

5575011

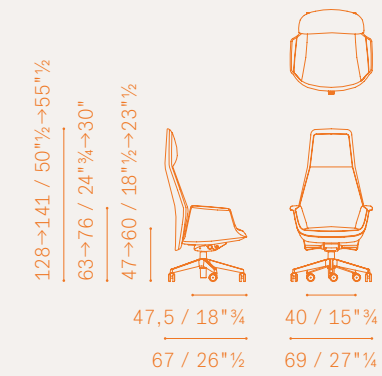

## DownTown Executive — Castors or glides

5575021

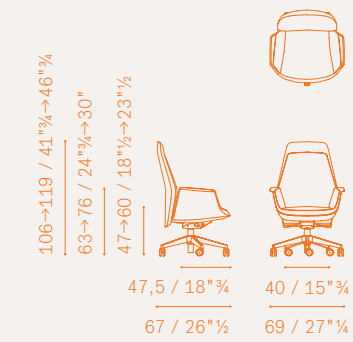

## DownTown Managerial — Castors or glides

5575031

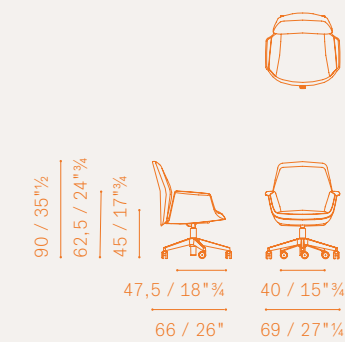

## DownTown Meeting — Castors or glides

5575041

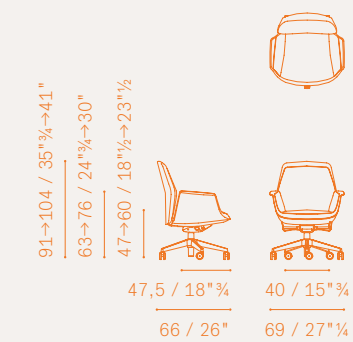

## DownTown Visitor — Glides

5575061

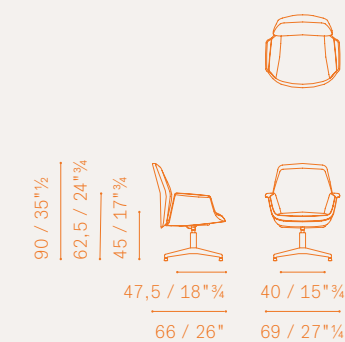

## DownTown — Finishings

### Upholstery

- Pelle Frau® leather from the ColorSphere®
- Micro-perforated Pelle Frau® leather from the ColorSphere®
- Fabric A
- Fabric B
- Fabric C
- Fabric C.O.M.

### Base

- Aluminium in a black finish
- Polished aluminium

# Poltrona Frau Style & Design Centre

## Forum



### POLTRONA FRAU STYLE & DESIGN CENTRE

Dalla seconda metà degli anni sessanta Poltrona Frau ha creato una struttura interna che si occupa di ricerca e sviluppo. Ogni giorno, accanto alla salvaguardia del know-how di alta artigianalità, il Centro Ricerche e Sviluppo sperimenta nuovi materiali, nuove tecniche costruttive e realizza nuove forme. Il gruppo, che è formato da tecnici altamente specializzati nella progettazione, può contare su di un attrezzatissimo reparto di prototipazione nel quale dare forma alle nuove idee. Molto efficace, per la messa a punto di prodotti eccellenti nella qualità e conformi alle normative internazionali, è il Laboratorio di Analisi e Sperimentazione nel quale vengono testati i prodotti e le materie prime.

### CONCEPT

Una ricca collezione di sedute per l'ufficio direzionale e di medio livello che riprende le forme classiche e i dettagli propri della tradizione artigiana Poltrona Frau, come il ricciolo a voluta dello schienale e del sedile.

### POLTRONA FRAU STYLE & DESIGN CENTRE

Poltrona Frau, Second half of the 60. In the second half of the 1960s, Poltrona Frau created an internal structure to manage research and development. Whilst preserving the know-how of expert craftsmanship, the Centre for Research and Development experiments with new material, new building techniques and creates new forms. The highly specialised design technicians that make up the group benefit from a superbly equipped prototype laboratory, where they can give form to new ideas. Products and raw material are tested in the Analysis and Experimentation Laboratory, a very efficient structure for the fine-tuning of high-quality products conforming international norms.

### CONCEPT

A rich collection of executive and middle-management seating that suggests a revival of classic forms and details typical of Poltrona Frau's craft tradition, for example the scrolls on the backrest and seat.

### ポルトローナ・フラウ研究開発センター

1960年代後半、ポルトローナ・フラウは社内に研究開発部門を開設。高度なクラフツマンシップのノウハウを大切に保ちつつ、研究開発センターでは新しい素材、新しい製造技術を研究し、新たなフォルムを開発している。当グループはデザイン・設計部に高度な専門技術を持つ技術者を擁し、新しい発想を具現化するプロトタイプ部門の設備も極めて充実しているため、高品質で国際規格に適合する製品を生み出すのに役立っている。素材や製品をテストする分析・実験ラボの役割も担っている。

### コンセプト

エグゼクティブや幹部のオフィス用高級コレクション。クラシックなフォルム、渦形装飾を始めとするディテールにポルトローナ・フラウならではの伝統的クラフツマンシップが際立つ。

### POLTRONA FRAU STYLE & DESIGN CENTRE

20世紀60年代后期、Poltrona Frau 成立了内部研发部门。在保持专业制造工艺知识的同时，研发中心还专注于新材料、新建筑技术和新造型的研究。研发中心高度专业化的设计人员可利用配备精良的原型实验室，从而形成新的设计概念。产品和原材料在分析实验室进行试验，可对符合国际标准的高质量产品进行有效的精确调整。

### 理念

各种款式的高管和中级管理层座椅，充分体现了 Poltrona Frau 特有传统工艺的经典形式和细节，如靠背和座面的涡卷褶皱。



Forum ha la struttura portante in legno con terminale a voluta. Il rivestimento è in Pelle Frau® del ColorSphere® arricchito da una trapunta in pelle su sedile e schienale. Il basamento a 5 razze è disponibile in alluminio verniciato nero o lucido attrezzabile con ruote di vario tipo o scivoli.

Solid wood structure. A leather upholstered quilt gives to the back and to the seat a more elegant look. Five stars base available in black epoxy or polished aluminium finish on either castors (many types are available) or glides.

Forum のフレームはウッド製で、先端に渦形装飾が見られる。革張りはカラー・システムの Pelle Frau® ペッレ・フラウ®。座部と背もたれのレザーに特別なキルティングを施し、高級感が際立つ。主柱から脚が5本。ブラック塗装仕上げ又は光沢仕上げのアルミ製。種々のキャスター、又はグライダー・キャスター付。

实木框架结构。皮革套面配以精致的缝线，使得座椅和后背看起来更显高雅。五轮底座采用黑色环氧涂料或抛光铝饰面配有各种款型的滑轮或导轨。







Regolabili in altezza e rotabili su stesse, le versioni President, Executive e Managerial sono dotate anche di un meccanismo di oscillazione di schienale e sedile con blocchi intermedi. La versione Meeting è disponibile con un meccanismo di rotazione con ritorno nella posizione di partenza.

The President, Executive and Managerial versions are height adjustable, rotate, and are fitted with a turning mechanism for seat and backrest with lock-in positions. Fully rotating, the Meeting version can be also equipped with an automatic return rotation mechanism.

高さ調節可能で回転式、President、Executive、Managerial のモデルでは、背部と座部がリクライニング式で数段階調節可能。Meeting のモデルはオートリターン機能付。

总裁椅、行政椅和经理椅版本均可调节高度可旋转并配有旋转装置使座位和后背可锁定状态。可自由旋转，会议椅和大会议椅版本也装备了自动还原旋转装置。



# Forum President / Executive / Managerial / Meeting



## Forum

### Forum President

5232011

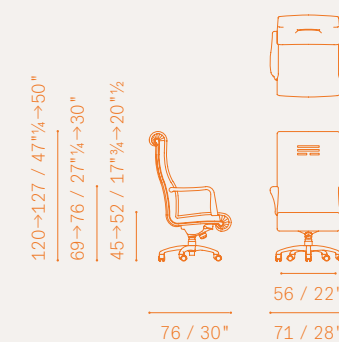

### Forum Executive

5232021

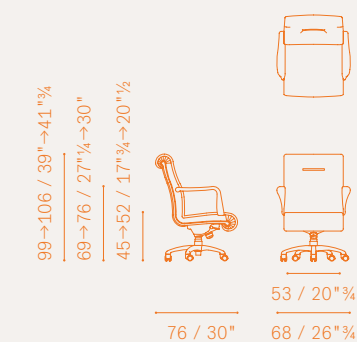

### Forum Managerial — with armrests

5232031

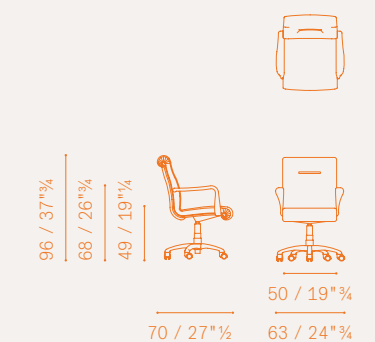

### Forum Managerial — without armrests

5232031

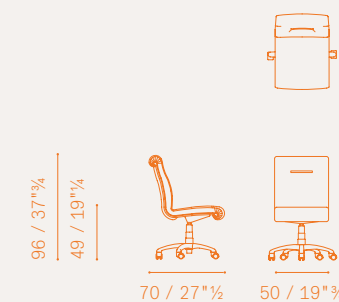

### Forum Meeting — with armrests

5232041

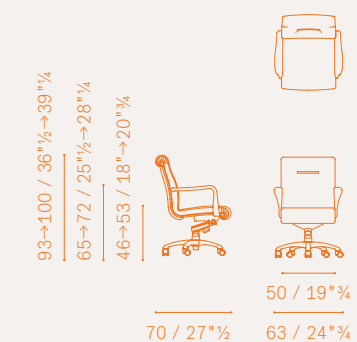

### Forum Meeting — with armrests

5232041

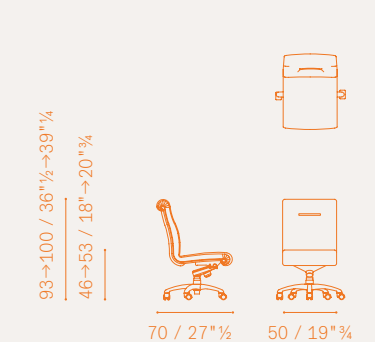

### DownTown — Finishings

#### Upholstery

— Pelle Frau® leather from the ColorSphere®

#### Base

— Aluminium in a black finish  
 — Polished aluminium

#### Supports

— Soft, self-braking "W" type castors — Hard, self-braking swivel castors  
 — Free-rolling soft castors — Free-rolling hard castors  
 — Swivel glides (2 cm lower height)

#### Forum Meeting

— with "Back to position mechanism" and swivel glides  
 — without "Back to position mechanism"

Roberto  
Lazzeroni

# Ginger Ale



## CONCEPT

La poltroncina Ginger Ale è la variante semplificata e più informale della poltroncina Ginger, seduta di grandissimo successo nel catalogo Poltrona Frau. Comoda, versatile, elegante, la poltroncina Ginger Ale si presta con versatilità sia agli spazi di lavoro, come seduta per singole postazioni o sale riunioni, che agli spazi domestici, per la zona studio o pranzo. Proprio per venire incontro a ogni tipo di esigenza, Roberto Lazzeroni la disegna sia con base metallica verniciata sia con gambe in legno per un totale di cinque basamenti diversi.

## CONCEPT

The Ginger Ale armchair is a simplified and more informal version of the Ginger armchair, one of the most successful chairs in the Poltrona Frau catalogue. Comfortable, versatile and elegant, the Ginger Ale armchair lends itself both to workspaces, individual workstations or meeting rooms, as well as domestic settings, such as the study or dining room. With the specific aim of catering for all needs, Roberto Lazzeroni designed it with both a painted metal base and with wooden legs, allowing for a total of five different bases.

## コンセプト

ミニアームチェア「Ginger Ale」は、Poltrona Frauのカタログ中でも大人気のいすであるミニアームチェア「Ginger」のシンプルでインフォーマルなバージョンです。快適で、多様性に富み、エレガントなミニアームチェア「Ginger Ale」は、職場では、各人の席や会議室用に、ご家庭内の空間では書斎、食事エリア用に、多様なニーズに応えます。ロベルト・ラッゼローニは、あらゆるニーズに対応するために、金属ベース塗装バージョン、木製脚付きバージョンなど、5種類のベース・バージョンをデザインしました。

## 理念

Ginger Ale小沙发椅是Ginger小沙发椅 - Poltrona Frau样本中一款获得巨大成功的座椅 - 的简化和非正式版本。舒适、灵活、典雅，Ginger Ale小沙发椅既可灵活适应工作空间，当作单独座椅或会议室座椅，也可适应家居空间，在书房或餐厅使用。正是为了满足各种需求，Roberto Lazzeroni为其设计了总共五种不同的底座，包括漆面金属底座和木制椅腿。



Le basi metalliche sono quattro e sono disponibili in due finiture, Cemento e Antracite:

- la base con gambe coniche
- la base a cinque razze con ruote, disponibile sia nella versione girevole 360° ad altezza fissa, sia nella versione con molla a gas per la regolazione dell'altezza seduta. Le ruote sono piroettanti auto-frenanti morbide, con supporto in plastica nera per le versioni verniciate.

There are four metal bases which are available in two finishes, Cemento and Antracite:

- base with conical legs
- 5-spoke base with castors, available in both the 360° swivel version with fixed height and version with height-adjustable gas spring. The wheels are soft self-braking swivel castors with black plastic support for the painted versions.

金属ベースは以下の4種類で、それぞれセメントカラー仕上げと無煙炭カラー仕上げの2バージョンでご用意できます。

- 円錐脚付きのベース
- 5本スポーク式タイヤ型ベースは、固定高で360°回転バージョンと、座面高調節用のガス式スプリングが付いたバージョンがあります。ピルエットタイヤはソフトセルフロック式で、ピルエット式タイヤで、塗装バージョンにはブラックカラーのプラスチック製サポートが付いています。

金属基底有四款，有两种饰面可供选择：Cemento（混凝土色）和Antracite（无烟煤色）：

- 带有锥形椅腿的底座
- 五支爪轮底座，分为固定高度360° 旋转款和座垫高度可调的空气弹簧款。自转轮带有柔和的自制动装置，漆面版本配有黑色塑料支撑。



- la base a quattro razze  
 - la base con colonna, sia in versione fissa sia girevole, con dispositivo ammortizzatore e rientro automatico al punto di partenza.  
 Oltre ai quattro basamenti in metallo, Ginger Ale è disponibile anche con quattro gambe in massello di frassino a sezione triangolare, disponibile nelle finiture tinto Moka o tinto Wengé, tinto a campione o laccato RAL a campione.

- four-spoke base  
 - base with column, in both the fixed and swivel versions, with shock absorbing device and automatic return to the starting position.  
 As well as the four metal bases, Ginger Ale is also available with four triangular-profile solid ash legs, available with moka or wenge-stained finishes, stained according to sample or with RAL lacquer based on a sample.

- 4本スポーク式ベース。  
 - 円柱ベースは、固定タイプも回転タイプも、ショックアブソーバー機能と自動的に元の位置に戻るオートリターン機能が搭載されています。「Ginger Ale」は、この4種類の金属脚以外に、三角断面のトネリコ材製の脚4本タイプがあり、モカカラー、ウエンゲーカラー、色見本、RAL色見本による塗装仕上げでのご用意が可能です。

- 四支爪底座  
 - 带立柱底座，可以为固定或旋转版本，带有缓冲装置，自动回到初始点。  
 除了四种金属底座外，Ginger Ale还提供白蜡木实木三角截面四椅腿版本，有摩卡色或鸡翅木色表面可选，另外还可根据样品上色或根据样品进行RAL色上漆。





La scocca della poltroncina Ginger Ale è realizzata in polimero termoplastico composito ottenuto da stampo e imbottita in poliuretano espanso. È disponibile:

- verniciata colore Antracite
- verniciata colore Cemento
- interamente rivestita in Pelle Frau®
- interamente rivestita in tessuto Kvadrat by Poltrona Frau.

The shell of the Ginger Ale armchair is made from moulded thermoplastic composite polymer and padded with polyurethane foam. It is available:

- painted in anthracite colour (Antracite)
- painted in cement colour (Cemento)
- entirely upholstered in Pelle Frau® leather
- entirely upholstered in Kvadrat by Poltrona Frau fabric.

ミニアームチェア「Ginger Ale」のボディーは金型成型による熱塑性型ポリマー製で、発泡ポリウレタンのパッド材を使用しています。以下の4バージョンのご用意が可能です。

- 無煙炭カラー塗装
- セメントカラー塗装
- Pelle Frau®で全体を上張り
- Poltrona Frauがクヴァドラ社ファブリックで全体を上張り

Ginger Ale小扶手椅主体采用印压成型合成热塑聚酯制作，填充聚氨酯泡沫。提供：

- Antracite（无烟煤）色漆面
- Cemento（混凝土）色漆面
- 完全覆盖Pelle Frau SC软皮。
- 完全覆盖Kvadrat by Poltrona Frau布艺。





Poltrona con base a 5 razze con ruote  
(altezza fissa o regolabile)

Armchair with 5-spoke base  
(fixed or adjustment height)

5 スポーク・ベース付きアームチェア  
(高さ固定もしくは可動式)

5 星滚轮单椅 (固定高度或高度可调)



Poltrona con base a 4 razze

Armchair with 4-spoke column base  
(fixed or swivel)

4 スポーク・コントラクト・ベース付きアームチェア (固定もしくは回転式)

4 腿扶椅 (固定或可旋转)



Poltrona con base metallica  
e gambe coniche

Armchair with conical metal supports

金属製円錐形脚部付アームチェア

椅脚为锥形的金属支脚



Poltrona con colonna a 4 razze  
(fissa o girevole)

Armchair with 4-spoke base

4 スポーク・ベース付きアームチェア

4 星轮辐单椅



Poltrona con gambe in legno e scocca  
della seduta mono-materiale (pelle  
o tessuto)

Armchair with wooden legs and mono-  
material seat shell (leather or fabric)

木製の脚とシェルを備えたアームチェア  
モノマテリアルシート (レザーまたは  
生地)

带木腿和外壳的扶手椅单一材料座椅  
(皮革或织物)



**Ginger Ale** — Armchair 5-spokes base with castors and adjustable height / External varnished shell

5542017

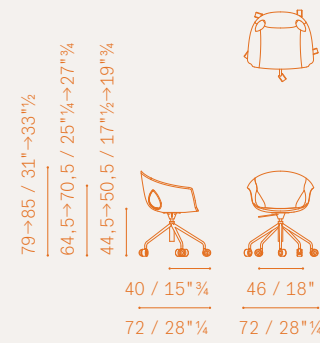

**Ginger Ale** — Armchair 5-spokes base with castors / Totally upholstered shell

5542017

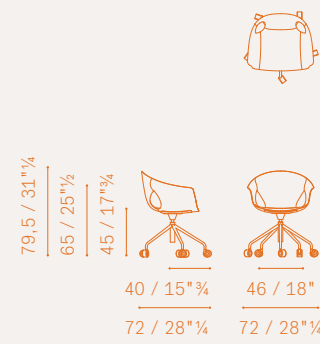

**Ginger Ale** — Armchair 4-spokes base / Totally upholstered shell

5542018

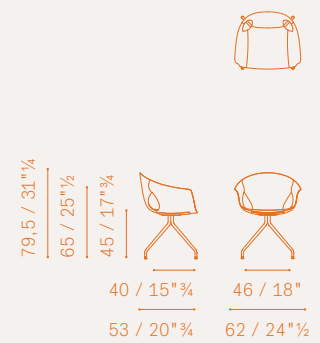

**Ginger Ale** — Armchair 5-spokes base with castors / External varnished shell

5542017

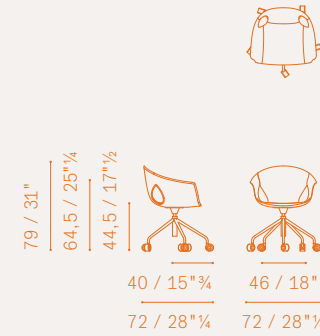

**Ginger Ale** — Armchair 5-spokes base with castors and adjustable height / Totally upholstered shell

5542017

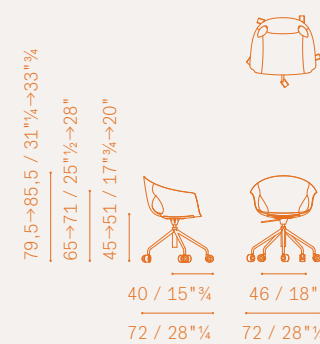

**Ginger Ale** — Armchair 4-legs base / External varnished shell fixed chair

5542017

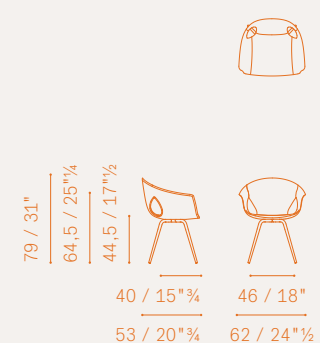

**Please note:**

this catalogue shows only some technical drawings, in order to know all the availabilities please refer to the current price list.

**Ginger Ale** — Armchair 4-legs base / Totally upholstered shell fixed chair

5542017

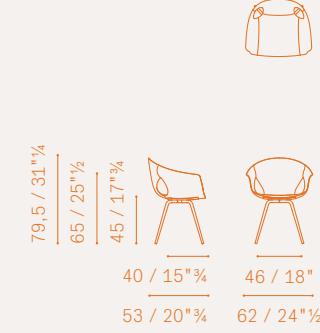

**Ginger Ale** — Armchair column base / External varnished shell

5542016

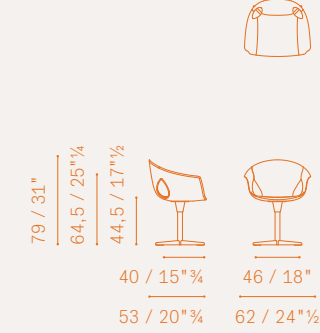

**Ginger Ale** — Full upholstery shell Fixed chair swivel chair

5542101

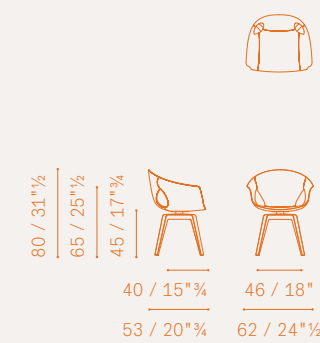

**Ginger Ale** — Armchair column base / Totally upholstered shell

5542016

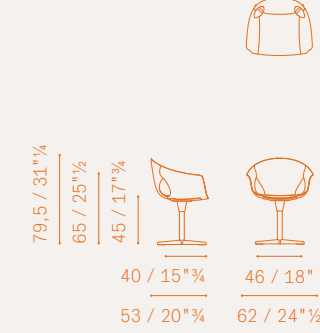

**Ginger Ale** — Armchair wood legs base / Totally upholstered shell fixed chair

5542017

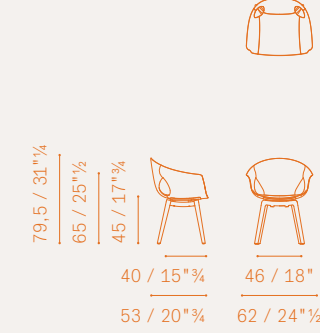

**Ginger Ale** — Full upholstery shell swivel chair

5542101

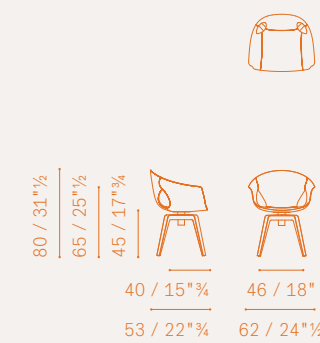

# Poltrona Frau Style & Design Centre

## Oxford



### POLTRONA FRAU STYLE & DESIGN CENTRE

Dalla seconda metà degli anni sessanta Poltrona Frau ha creato una struttura interna che si occupa di ricerca e sviluppo. Ogni giorno, accanto alla salvaguardia del know-how di alta artigianalità, il Centro Ricerche e Sviluppo sperimenta nuovi materiali, nuove tecniche costruttive e realizza nuove forme. Il gruppo, che è formato da tecnici altamente specializzati nella progettazione, può contare su di un attrezzatissimo reparto di prototipazione nel quale dare forma alle nuove idee. Molto efficace, per la messa a punto di prodotti eccellenti nella qualità e conformi alle normative internazionali, è il Laboratorio di Analisi e Sperimentazione nel quale vengono testati i prodotti e le materie prime.

### CONCEPT

Lavorazione capitonné per una poltrona d'ufficio pensata per chi ama le linee classiche e tradizionali. Design che riporta alla memoria le prestigiose sedute d'ufficio inglesi del primo Novecento.

### POLTRONA FRAU STYLE & DESIGN CENTRE

In the second half of the 1960s, Poltrona Frau created an internal structure to manage research and development. Whilst preserving the know-how of expert craftsmanship, the Centre for Research and Development experiments with new material, new building techniques and creates new forms. The highly specialised design technicians that make up the group benefit from a superbly equipped prototype laboratory, where they can give form to new ideas. Products and raw material are tested in the Analysis and Experimentation Laboratory, a very efficient structure for the fine-tuning of high-quality products conforming international norms.

### CONCEPT

This quilted treated office armchair has been conceived for those who love classical, traditional lines. Its design calls to mind the high-prestige chairs typical of early 20th century English office furniture.

### ポルトローナ・フラウ研究開発センター

1960年代後半、ポルトローナ・フラウは社内には研究開発部門を開発。高度なクラフツマンシップのノウハウを大切に保ちつつ、研究開発センターでは新しい素材、新しい製造技術を研究し、新たなフォルムを開発している。当グループはデザイン・設計部に高度な専門技術を持つ技術者を擁し、新しい発想を具現化するプロトタイプ部門の設備も極めて充実しているため、高品質で国際規格に適合する製品を生

み出すのに役立っている。素材や製品をテストする分析・実験ラボの役割も担っている。

### コンセプト

クラシックな趣と伝統を愛する方のために、オフィス用アームチェアに“カビトネ”の手法を用いる。1900年代初頭の英国の格調高いオフィスを彷彿させるデザイン。

### POLTRONA FRAU STYLE & DESIGN CENTRE

20世紀60年代后期，Poltrona Frau 成立了内部研发部门。在保持专业制造工艺知识的同时，研发中心还专注于新材料、新建筑技术和新造型的研究。研发中心高度专业化的设计人员可利用配备精良的原型实验室，从而形成新的设计概念。产品和原材料在分析实验室进行试验，可对符合国际标准的高质量产品进行有效的精确调整。

### 理念

这款办公扶手椅采用绗缝工艺，为那些热爱经典，崇尚传统的人士而生。它的设计让人回忆起 20 世纪早期英国办公家具中具有崇高声望的椅子的典型特征。





Girevoli, regolabili in altezza con molle a gas e basculanti con blocchi intermedi, le versioni Oxford President e Executive hanno il basamento a cinque razze disponibile in legno nocino d'America tinto noce medio, in alluminio verniciato con polvere epossidica nera o lucidato.

President and Executive versions are fully rotating, gas spring height adjustable and reclining with several fixed settings. The five-star base is made from American black walnut in a medium walnut stain, or from aluminium in a black epoxy or chrome finish.

回転式、ガス・シリンダーで高さ調節可能。リクライニングもでき、数段階の調節が可能。Oxford PresidentとExecutiveの5本脚付支柱はミディアム・ウォールナット・カラーのアメリカン・ウォールナット、もしくはブラックのエポキシ仕上げ又は光沢仕上げのアルミ製。

总裁椅和行政椅版本可自由旋转，气压式可调节高度装置，有几种固定的躺位设置可调。星形底座采用中度颜色的胡桃木染色的美国黑胡桃木，也可选择黑色涂层或抛光铝饰面。



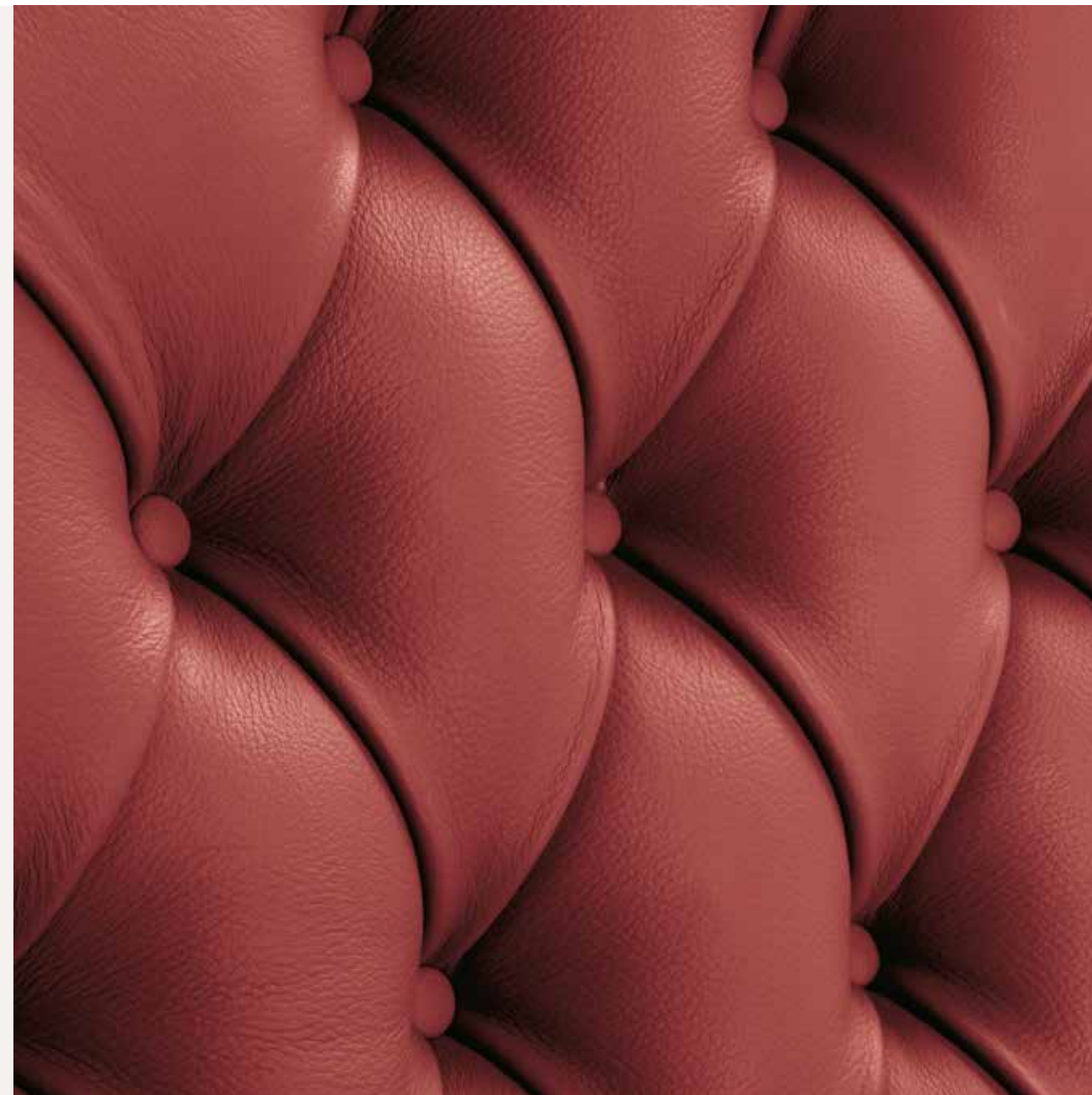

La struttura è realizzata in faggio stagionato con rivestimento in Pelle Frau® del ColorSphere® arricchito da lavorazione capitonné eseguito a mano per la superficie interna. Nella versione Visitor le gambe sono fisse e in faggio tinto noce medio.

Seasoned beechwood structure upholstered in Pelle Frau® leather from the ColorSphere® with hand-finished capitonné quilting. Visitor version is only available with fixed, beech wood in a medium walnut stained legs.

構造はシーズニングしたブナ材、革張りはカラー・システムの Pelle Frau® ペルレ・フラウ®、手作業で施すカピトネのボタン留めにより高級感が際立つ。Visitor の脚は常にミディアム・ウォールナット・カラーのアメリカン・ウォールナット。

该扶手椅框架采用风干榉木，套面可用 Pelle Frau® 色彩系统的皮革并配以手工缝线。访客版椅脚只适用中度颜色的胡桃木染色的美国黑胡桃木。

# Oxford

## President / Executive / Visitor



# Oxford

## Oxford President

5233011

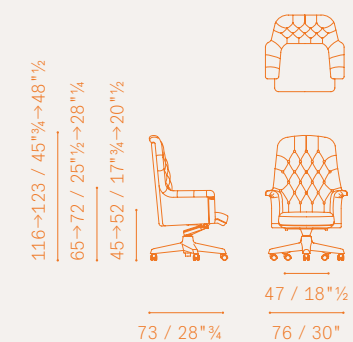

## Oxford President aluminium

5233011

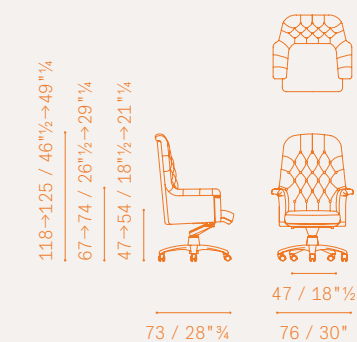

## Oxford Executive

5233021

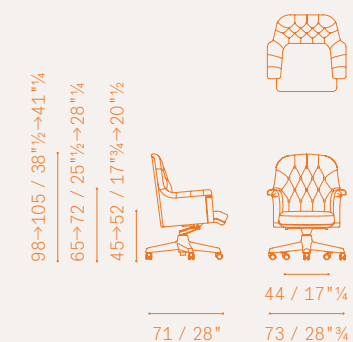

## Oxford Executive aluminium

5233021

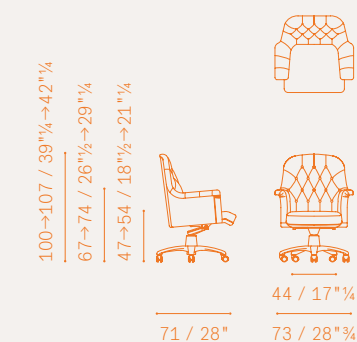

## Oxford Visitor

5233061

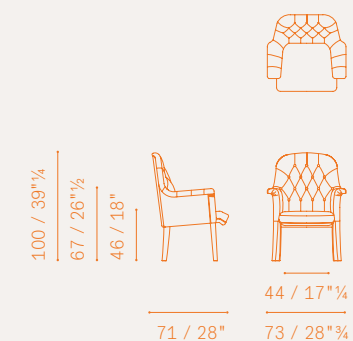

## DownTown — Finishings Oxford Visitor

Upholstery  
 — Pelle Frau® leather from the ColorSphere®

## Oxford President / Executive

### Base

- Beech wood in a medium walnut stain
- Aluminium in a black finish
- Polished aluminium

### Supports

- Soft, self-braking "W" type castors — Hard, self-braking swivel castors
- Free-rolling soft castors — Free-rolling hard castors
- Swivel glides (2 cm lower height)

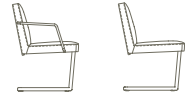

Chancellor Conference — 278



DownTown Conference — 282



Movie — 289

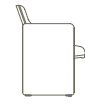

THF — 293

## Office Collection Poltrona Frau

# Multifunctional chairs

Chancellor Conference  
DownTown Conference  
Movie — THF



# Chancellor Conference





Chancellor Conference con base a slitta completa la famiglia di poltrone ufficio Chancellor. La base d'appoggio è in tubolare d'acciaio cromato o verniciato colore grigio scuro. Il rivestimento è in Pelle Frau® del ColorSphere®. I braccioli, nella versione che li prevede, sono in tubolare di acciaio rivestiti in pelle e rifiniti con attacchi terminali alla struttura in alluminio lucido o verniciati grigio scuro.

Chancellor Conference with sled base completes the range of Chancellor office armchairs. The structure is in moulded polyurethane foam with a metal insert. The tubular steel resting base is available in a polished chrome plate or in a dark grey finish with plastic feet. Upholstered in Pelle Frau® leather from the ColorSphere®. The armrests, in the armchair version, are in tubular steel upholstered in leather and finished with ends attached to the structure in a polished aluminium or dark grey finish.

Chancellor のオフィス用アームチェアのシリーズを締めくくることが滑り座のついた Chancellor Conference。支柱はクロム仕上げ又はダークグレー塗装仕上げのスチール製パイプ材。革張りは Pelle Frau® ColorSphere® カラー・システムのペッレ・フラウ®。肘掛はスチール製パイプ材の革張り、端は光沢仕上げ又はダークグレー塗装仕上げのアルミ製。

Chancellor Conference, 雪橇式底座，完善了 Chancellor 办公扶手椅系列。框架由金属制成，包裹聚氨酯泡沫。管状钢制支撑底座可采用抛光镀铬金属板或是深灰色涂层塑料脚。套面可使用 Pelle Frau® 色彩系统的皮革。在扶手椅版本中，扶手倚靠部分采用管状钢制结构配以皮革软包，尽头处的金属连接采用抛光铝或深灰涂层。

## Chancellor Conference

### Chancellor Conference with armrests

5503060

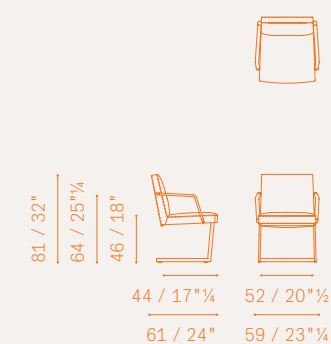

### Chancellor Conference

5503060

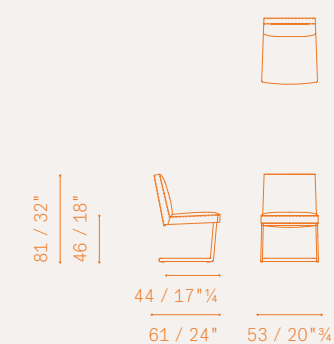

### Chancellor Conference — Finishings Oxford Visitor

#### Upholstery

— Pelle Frau® leather from the ColorSphere®

#### Base

— Metal in a dark grey finish  
— Chrome finished metal

#### Stitching

— In matching tones thread  
— With a contrast thread

Jean-Marie  
Massaud

# DownTown Conference



Poltrone Conferenza — DownTown

Conference Armchairs — DownTown

会議場用アームチェア — DownTown

会议扶手椅 — DownTown





I tre modelli Conference, ideali per le aree di riunione e incontro, mantengono la scocca dal design morbido e avvolgente e offrono tre diversi sistemi di appoggio a terra. Conference Bridge, con i braccioli che racchiudono la scocca ai due lati e arrivano fino a terra, è completa di ruote.

The three Conference models, ideal for meeting areas, have the same soft, enveloping shell design and offer three new leg systems. Bridge Conference envelop the shell on both sides and reach down to the ground, complete with wheels.

会議や会合のスペースに理想的な Conference の 3 つのモデルは柔らかで心地よいデザインのシェルが共通ですが、支脚システムを3タイプからお選び頂けるようになりました。Conference Bridge はシェル両側のアームレストが床まで届くほど長く、キャスターを覆い隠しています。

三款 Conference 适合会议和会面区.保留了采用柔软包容设计的主体部分, 采用三种不同的地面支撑部分。Conference Bridge 扶手, 从两侧包裹主体, 一直延伸到地面, 配有轮子。







Conference girevole con basamento a 4 razze e rotazione a 360° con meccanismo di ritorno alla posizione di partenza. Conference con base a slitta e elegante sezione a lama. Le basi a razze e a slitta sono in acciaio cromato, oppure verniciato nero.

Swivel Conference with 4-spoke base and 360° swivel with a mechanism that returns it to its starting point. Sled-base Conference with elegant blade cross-section. The spoke and sled bases come in chrome steel, or painted black.

4 脚ベース式とオートリターンタイプの360度回転式 Conference。グライド脚ベースとエレガントなブレード型の Conference。4 脚ベースとグライド脚ベースはブラック、チタン色またはクローム加工スチール製です。

三款 Conference 适合会议和会面区，保留了采用柔软包容设计的主体部分，采用三种不同的地面支撑部分。Conference bridge 扶手，从两侧包裹主体，一直延伸到地面，配有轮子。

## DownTown Conference

### DownTown Conference — Glides

5575016

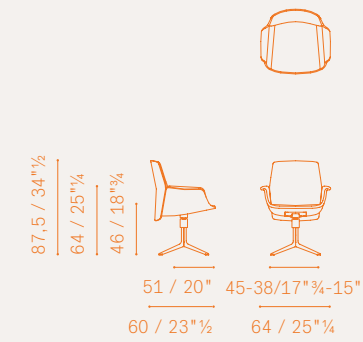

### DownTown Conference — Glides

5575060

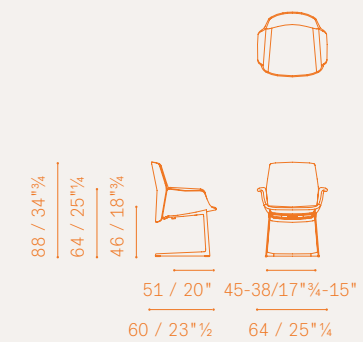

### DownTown Conference — Glides

5575051

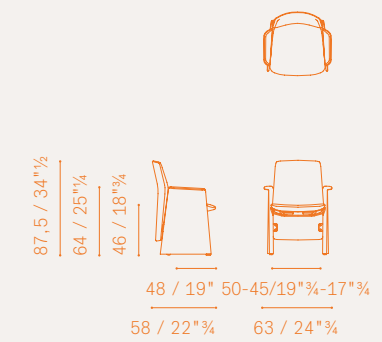

### DownTown Conference — Finishings

#### TECHNICAL FEATURES

**Base.**  
Swivel: 4-spokes base with support enabling the rotation and return to the starting position.  
Cantilever base: in steel with a bladed section

**Caps.**  
Swivel, Cantilever base: in transparent plastic material.  
Bridge: front caps in black plastic material.

**Base finishings (excluding Bridge item).**  
- Titanium painted steel  
- Black painted steel  
- Chromed steel

**Support (excluding Bridge item): one-way castors.**

**Seat, armrest upholstery:**  
- ColorSphere® (SC)  
- Fabric A  
- Fabric B  
- Fabric C  
- C.O.M.

**Removability. Not possible.**

↑ Downtown Conference Swivel, with 4-spokes base Kvadrat Hallingdal 65 colour 694

↑ Downtown Conference Cantilever base, Pelle Frau® SC 28 Seppia

↑ Downtown Conference Bridge, Kvadrat Hallingdal 65 colour 407

Mario  
Marenco

# Movie



Poltrone Conferenza — Movie

Conference Armchairs — Movie

会議場用アームチェア — Movie

会议扶手椅 — Movie



La struttura è in tubolare di acciaio, verniciato nero opaco oppure cromato. Il rivestimento è in Pelle Frau® del ColorSphere® con finitura dei bordi con levigatura e tinteggiatura a mano. Posizionabile in file con sistema d'aggancio, è impilabile fino a un massimo di 8 poltroncine. Il piano-scrittura, in policarbonato, è estraibile con sistema di innesto a baionetta.

The frame is made of black or chrome-finish steel tubing. It's upholstered in Pelle Frau® leather from the ColorSphere® with edges hand-polished and painted. The writing tablet attached to the support structure is made of polycarbonate. The chairs are stackable up to maximum of 8 chairs. They can also be connected side-to-side on demand.

構造はマットのブラック塗装又はクロム仕上げのスチール製パイプ材。革張りは Pelle Frau® ColorSphere® カラー・システムのペツレ・フラウ®。縁の研磨と塗装は手作業で行う。連結システムにより並列が可能。8脚まで積み重ねられる。メモ台の小さな天板はポリカーボネート製で差し込み式の接合。

框架采用黑色或镀铬管状不锈钢。套面使用 Pelle Frau® 色彩系列的皮革，边缘采用手工打磨着色。支撑框架上连接的写字板用塑料制成。椅子可叠起堆放，最多可以叠 8 把。也可以根据需求横向连接组合。

## Movie

### Movie

5182001

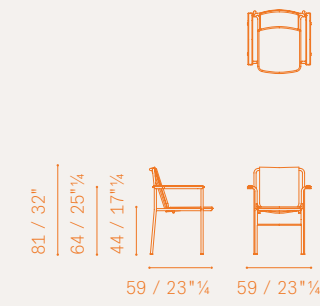

### Movie with writing surface

5182001

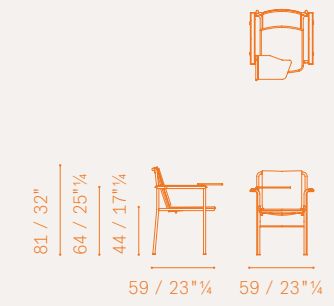

### Movie — Finishings

#### Structure

- Chrome finished
- Matt black finished

#### Accessories

- with writing surface
- without writing surface

#### Fixing system

- without fixing system
- with fixing system

Tito  
Agnoli

THF



Poltrone Conferenza — THF

Conference Armchairs — THF

会議場用アームチェア — THF

会议扶手椅 — THF





Una poltroncina dagli usi molteplici: seduta singola e serie di sedute in linea. L'imbottitura è in poliuretano ignifugo indeformabile. Il rivestimento è in Pelle Frau® del ColorSphere® o in tessuto fornito dal cliente. Un piccolo piano scrittoio può essere collocato a scomparsa nella gamba laterale. Disponibile con ruote o scivoli.

A multi-purpose armchair: as a single chair or row of seats. Non-deformable, fire-proof polyurethane padding. Upholstery is available in Pelle Frau® leather from the ColorSphere® or alternatively in the customer's own material. It can be equipped with a small writing top that disappears into a leg. Model available with castors or on glides.

様々な用途に使えるアームチェア: 一人掛けと並列がある。パッドの素材は難燃性形状安定ポリウレタン。Pelle Frau® ColorSphere® カラー・システムのベッレ・フラウ®で革張り又はクライアントから供給される生地を張る事も可能。メモ台の小さな天板は脚の中にたたみ込む事ができる。キャスター付かグライダー・キャスター付。

多功能扶手椅: 可作为单椅或成排座椅使用。填充为不变形防火聚氨酯。包括带有前单向和后旋转脚轮或导轨的款式。根据要求, 可配备写字板和连接系统。

## THF

### Oxford President

5122001

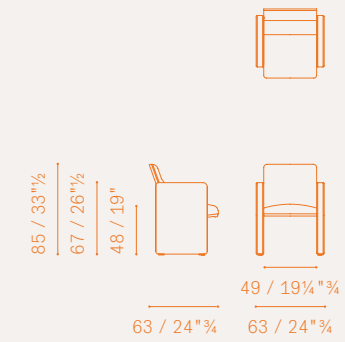

### Oxford President aluminium

5122001

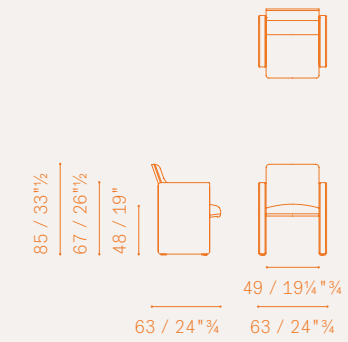

### Oxford Executive

5122001

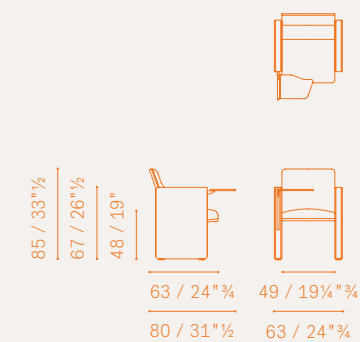

### THF — Finishings

#### Upholstery

- Pelle Frau® leather from the ColorSphere®
- Client's Own Material (C.O.M.)

#### Supports

- Unidirectional castors
- Unidirectional front castors and swivel rear castors
- Glides

#### Fixing system

- without fixing system
- with fixing system



## Part 2

# Home-Office Collection Index

SEDIE E POLTRONCINE  
CHAIRS AND SMALL ARMCHAIRS  
椅子和小扶手椅  
椅子と小さな肘掛け椅子

316 Archibald chair  
→ Jean-Marie Massaud

320 Donald  
→ Studio Cerri & Associati

322 Ginger  
→ Roberto Lazzeroni

326 Ginger Ale  
→ Roberto Lazzeroni

366 Technical Drawings  
→

TAVOLI E SCRIVANIE  
TABLES AND DESKS  
テーブル・デスク  
桌子和书桌

334 Fred  
→ Roberto Lazzeroni

336 Iren  
→ Kensaku Oshiro

340 Mesa Due  
→ Lella and Massimo Vignelli

344 Peek-a-Book  
→ Roberto Lazzeroni

350 Segreto  
→ Andr e Putman

LIBRERIE  
BOOKCASES  
本棚  
书柜

354 Jobs bookcase  
→ Jean-Marie Massaud

358 Lloyd  
→ Jean-Marie Massaud

362 Ren Bookcase  
→ Jean-Marie Massaud

# Poltrona Frau Home-Office Collection

La capacità di innovare è qualcosa che contraddistingue i leader, in qualsiasi spazio e momento.

Esistono forme e combinazioni materiche progettate per stimolare e accogliere questa innovazione, ridefinendo quella dimensione in cui esprimere le proprie capacità manageriale e creative.

Sono i capolavori di design per l'home-office di Poltrona Frau: esempi unici di virtuosismo progettuale, ideati per le diverse esigenze professionali in continuo mutamento.

Dalla nuova scrivania Peek-a-Book, che racchiude tutte le caratteristiche di eleganza e comfort per una zona studio, al moderno scrittoio Iren, una superficie dove poggiare i nuovi rituali del lavorare tra naturalezza e armonia.

Poltrona Frau supera i concetti di sedia e scrivania attraverso un nuovo modo di concepire e far dialogare gli elementi di una postazione da lavoro. Soluzioni dedicate all'home-office, nuove e innovative, che si aggiungono a prodotti iconici firmati Poltrona Frau.

La capacità di innovare è qualcosa che contraddistingue i leader, in qualsiasi spazio e momento.

Esistono forme e combinazioni materiche progettate per stimolare e accogliere questa innovazione, ridefinendo quella dimensione in cui esprimere le proprie capacità manageriale e creative.

Sono i capolavori di design per l'home-office di Poltrona Frau: esempi unici di virtuosismo progettuale, ideati per le diverse esigenze professionali in continuo mutamento.

Dalla nuova scrivania Peek-a-Book, che racchiude tutte le caratteristiche di eleganza e comfort per una zona studio, al moderno scrittoio Iren, una superficie dove poggiare i nuovi rituali del lavorare tra naturalezza e armonia.

Poltrona Frau supera i concetti di sedia e scrivania attraverso un nuovo modo di concepire e far dialogare gli elementi di una postazione da lavoro.

Soluzioni dedicate all'home-office, nuove e innovative, che si aggiungono a prodotti iconici firmati Poltrona Frau.

La capacità di innovare è qualcosa che contraddistingue i leader, in qualsiasi spazio e momento.

Esistono forme e combinazioni materiche progettate per stimolare e accogliere questa innovazione, ridefinendo quella dimensione in cui esprimere le proprie capacità manageriale e creative.

Sono i capolavori di design per l'home-office di Poltrona Frau: esempi unici di virtuosismo progettuale, ideati per le diverse esigenze professionali in continuo mutamento.

Dalla nuova scrivania Peek-a-Book, che racchiude tutte le caratteristiche di eleganza e comfort per una zona studio, al moderno scrittoio Iren, una superficie dove poggiare i nuovi rituali del lavorare tra naturalezza e armonia.

Poltrona Frau supera i concetti di sedia e scrivania attraverso un nuovo modo di concepire e far dialogare gli elementi di una postazione da lavoro. Soluzioni dedicate all'home-office, nuove e innovative, che si aggiungono a prodotti iconici firmati Poltrona Frau.

La capacità di innovare è qualcosa che contraddistingue i leader, in qualsiasi spazio e momento.

Esistono forme e combinazioni materiche progettate per stimolare e accogliere questa innovazione, ridefinendo quella dimensione in cui esprimere le proprie capacità manageriale e creative.

Sono i capolavori di design per l'home-office di Poltrona Frau: esempi unici di virtuosismo progettuale, ideati per le diverse esigenze professionali in continuo mutamento.

Dalla nuova scrivania Peek-a-Book, che racchiude tutte le caratteristiche di eleganza e comfort per una zona studio, al moderno scrittoio Iren, una superficie dove poggiare i nuovi rituali del lavorare tra naturalezza e armonia.

Poltrona Frau supera i concetti di sedia e scrivania attraverso un nuovo modo di concepire e far dialogare gli elementi di una postazione da lavoro.

Soluzioni dedicate all'home-office, nuove e innovative, che si aggiungono a prodotti iconici firmati Poltrona Frau.









↑ Iren wall desk, Saddle Extra Corda with moka ash structure; Archibald chair, Pelle Frau® SC 68 Sahara; Ren standing mirror, Saddle Extra Corda



↑ Leather Case, small size; Smart Home Diffuser, Pelle Frau® SC 279 Alchemy





↑ Peek-a-Book desk, Pelle Frau® SC 68 Sahara with ash in a wenge stain structure; Ginger Ale chair, fabric Steelcut trio 3 colour 916  
Mi low cabinet, Saddle Extra Cammello with Calacatta Gold marble top; Xi table lamp, Zaffiro glass with Saddle Extra Talpa band



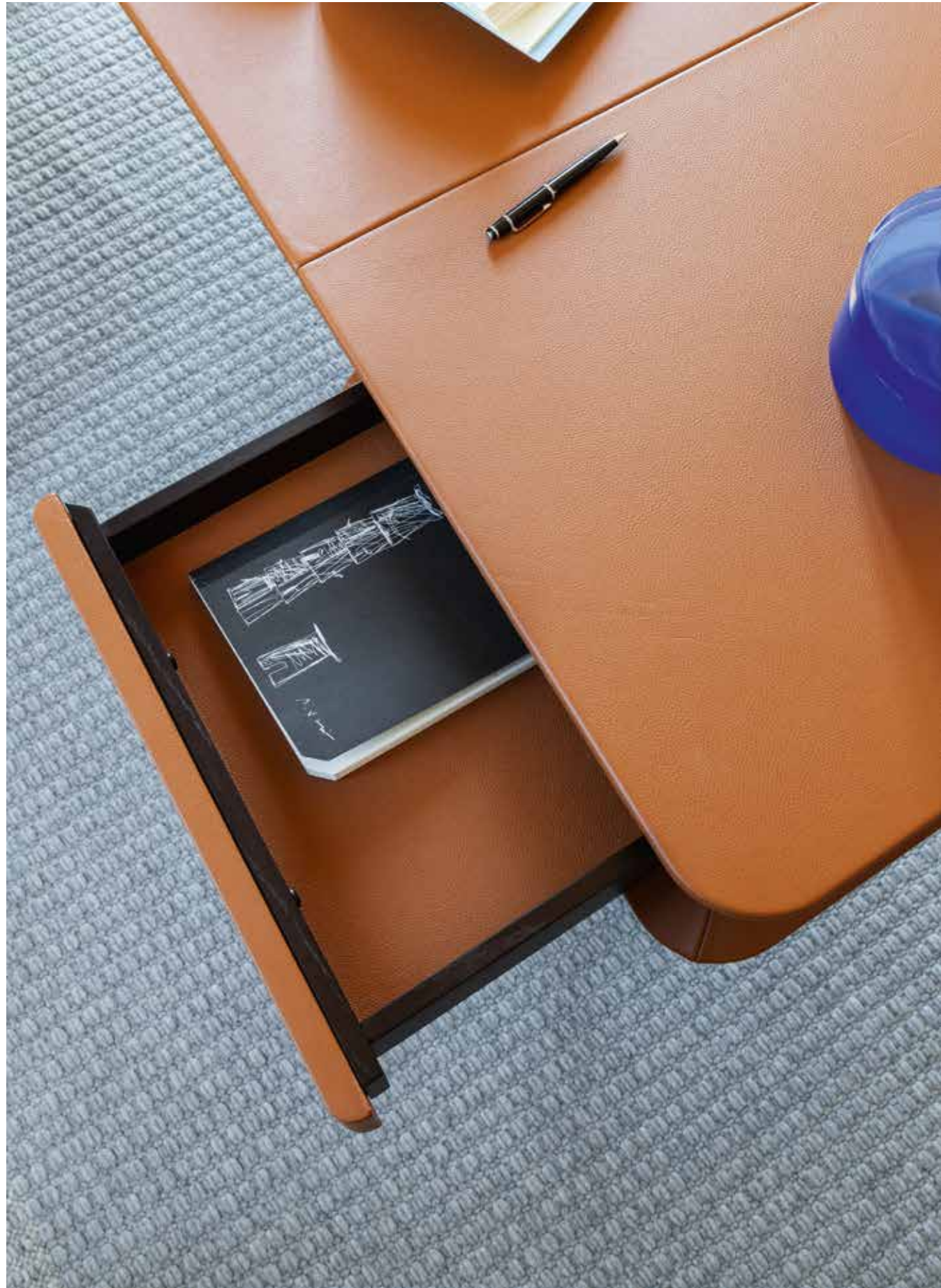



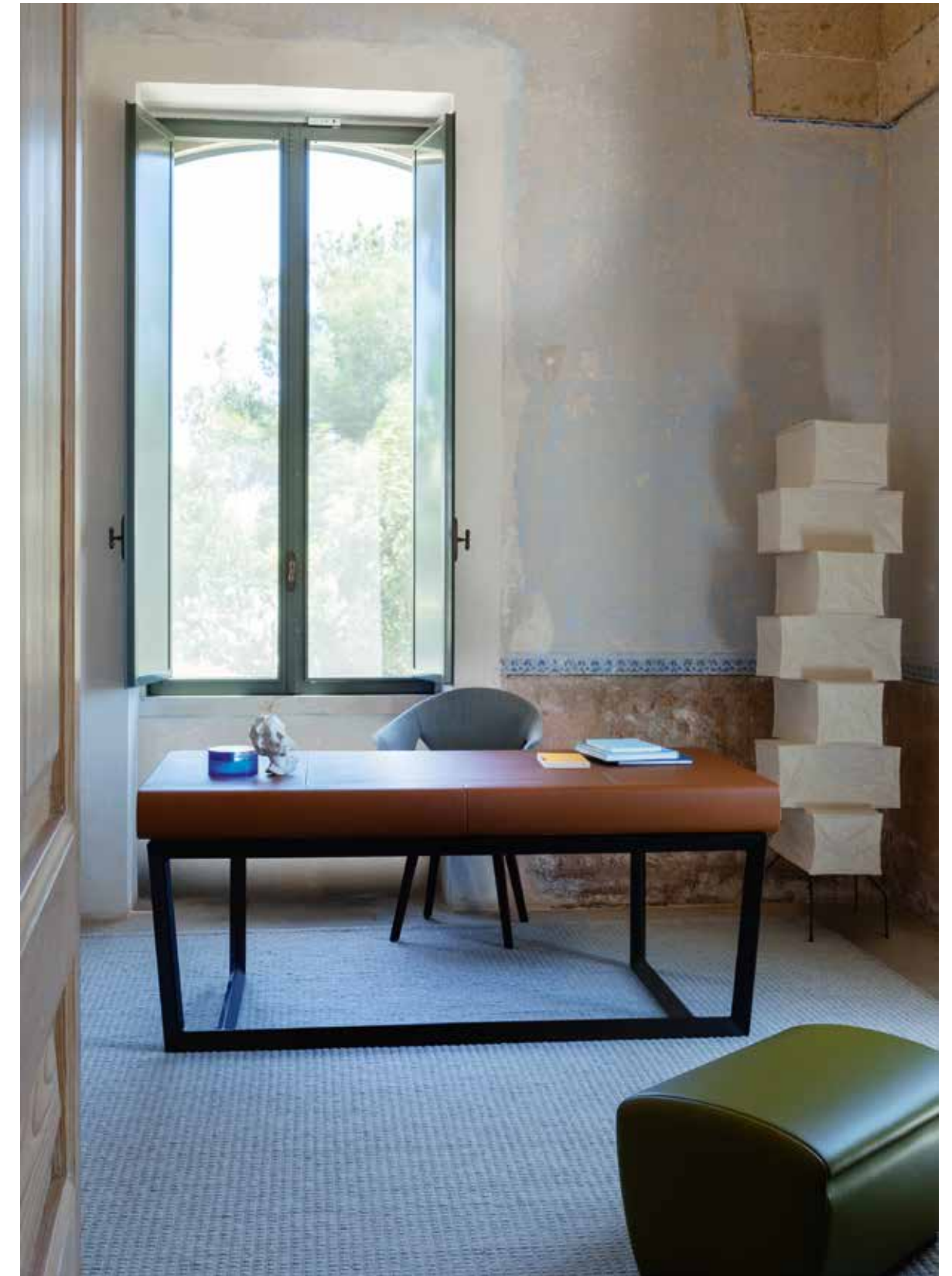

↖ Peek-a-Book desk, Pelle Frau® SC 68 Sahara with ash in a wenge stain structure;

↑ Ginger Ale chair, fabric Steelcut trio 3 colour 916; Vanity Fair XC ottoman with stotage, Pelle Frau® SC 175 Bengali Green







Archibald chair — 316



Donald — 320



Ginger — 322



Ginger Ale — 326

## Home-Office Collection Poltrona Frau

# Chairs and Small Armchairs

Archibald chair — Donald  
Ginger — Ginger Ale



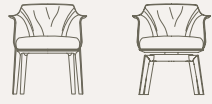

## Jean-Marie Massaud

# Archibald

### CONCEPT

Partendo dalla sua seduta-icona Archibald, Wallpaper\* Award per la sezione "Best Domestic Design" nel 2009, Jean-Marie Massaud crea un altro piccolo capolavoro, una dining chair di impeccabile eleganza.

La poltroncina Archibald ha un segno scolpito, netto, contemporaneo, ammorbidito da un tocco sartoriale che si rivela in ogni dettaglio: come il ricco movimento di pieghe sulla parte interna dello schienale rivestito in pelle. O l'accento di bracciolo, pensato come un bavero di camicia lasciato leggermente aperto con raffinata, studiata casualità. O ancora le preziose cuciture a contrasto, che sottolineano con sapiente discrezione la linea curva del dorso e dei profili.

Ultima nata della linea Archibald, che dieci anni fa si presentava come rivisitazione attualizzata della classica poltrona a pozzetto inglese, la nuova dining chair Archibald mantiene tutto il comfort della collezione, con un'allure più svelta e disinvolta che la rende particolarmente eclettica, ideale in ambienti contemporanei o, a contrasto, in contesti più classici.

### CONCEPT

Inspired by his iconic Archibald chair, Wallpaper\* Award in the "Best Domestic Design" section in 2009, Jean-Marie Massaud creates another little masterpiece, a dining chair of impeccable elegance.

The Archibald dining chair is sculpted, clean and contemporary, softened with a sartorial touch that is evident in every detail, like the sumptuous folds on the inside of the backrest upholstered in leather. Or the understated armrest that resembles a shirt collar that has been left slightly open with a casualness that is both deliberate and undeniably elegant. Or the precious contrast stitching, which discreetly and skilfully underlines the curved line of the back and profiles. The most recent addition to the Archibald collection, which ten years ago arrived on the scene as a contemporary take on the classic English tub chair, the new Archibald dining chair boasts all the comfort of the rest of the collection but has a sleeker, more casual allure that makes it particularly eclectic and perfect for both contemporary spaces and, conversely, more classic interiors.

### コンセプト

2009年ウォールペーパー賞ベストドメスティックデザイン賞の受賞作であるアイコン的なチェア「Archibald」をベースに、ジャン・マリー・マッソーがもう一つの小さな傑作、完璧なエレガンスが光るダイニングチェアを制作しました。

レザーの上張りを施した背面内側の動きのあるプリーツなど、テラードテイストのディテールが散りばめられたミニームチェア「Archibald」は柔らかく明快で現代的な彫刻のようなデザインが特徴です。計算されたカジュアルさ演出するやや外側に開いた上品な肘掛けはシャツの襟を彷彿させます。高級感溢れるコントラストの効いたステッチが背もたれと輪郭の曲線ラインを効果的にさりげなく強調しています。英国の古典的なタブチェアの現代リメイク版として10年前に発表された「Archibald」ラインの最新作であるダイニングチェア「Archibald」はコレクションの特徴であるコンフォートを完全に維持しつつ、さらにクレバーで個性的な魅力によって現代的な環境には勿論、よりクラシックな環境にも理想的な非常に機能性豊かなチェアです。

### 理念

由 Jean-Marie Massaud 设计的经典座椅 Archibald 曾于 2009 年获得 Wallpaper\* Award “最佳家居设计” 奖。此次，从这款座椅出发，他又创作出另一款小巧杰作：散发出完美无瑕优雅感的餐椅。

Archibald 小沙发椅具有清晰、当代的雕塑感，因展现在每一个细节里的缝纫元素而变得柔和：例如靠背内侧丰富的褶皱。又如扶手的深层含义，好似衬衫衣领，略微张开，展现细腻而极为考究的洒脱之感。再如珍贵的对比色缝线，巧妙而低调地突显靠背与外形轮廓的曲线。作为 Archibald 系列的最新成员，十年前，这一系列是作为经典英式半圆靠背沙发椅的当代版本而被推出，新款 Archibald 餐椅完整保留了本系列的舒适特点，并具有更加轻盈而从容的魅力，愈显兼收并蓄，是当代环境的理想选择，或者也可放在更具古典风格的环境中打造对比效果。





La scocca e i braccioli della poltroncina Archibald sono in poliuretano rigido ottenuto da stampo, mentre l'imbottitura interna è in poliuretano morbido stampato e ovatta poliestere. Il telaio della seduta è in multistrato di betulla, sempre con imbottitura in poliuretano espanso e ovatta. Il molleggio è ottenuto con molle elastiche. La base a quattro gambe è realizzata in legno massello di frassino nelle finiture tinte Wengé o Moka, con feltrini o scivoli protettivi a scelta sulle estremità. Può essere rivestita in Pelle Frau® o in tessuto. Nella versione in pelle è impreziosita da cuciture a contrasto.

The shell and armrests of the Archibald dining chair are made from moulded rigid polyurethane while the internal padding consists of soft moulded polyurethane and polyester wadding. The frame, also padded in polyurethane foam and wadding, is made from birch plywood. Elastic springs. The 4-legged base is made from solid ash with a Wenge or Moka stain, and has felt pads or a choice of protective guides at the ends of the legs. It can be upholstered in Pelle Frau® leather or fabric. The leather version is embellished with contrast stitching.

ミニアームチェア「Archibald」のボディーと肘掛けには金型成形硬質ポリウレタン、パディングには成型軟質ポリウレタンとポリエステル繊維綿が使用されています。座面のフレームはカバ材の積層板で、発泡ポリウレタンとポリエステル繊維綿のパディングが入っています。スプリング材には伸縮性バネが使用されています。4本脚ベースにはウエングーカーラーまたはモカカラーに染色されたトネリコ心材が使用されており、脚先には保護フェルトまたはスライドが備わっています(お好きな方を選択して頂けます)。Pelle Frau®またはファブリックでコーティングすることも可能です。レザーバージョンはコントラストの効いたステッチがアクセントになっています。

Archibald小沙发椅的骨架和扶手由模压成型硬质聚氨酯制成，内部填充模压成型软质聚氨酯和聚酯棉。座板框架使用桦木胶合板，同样填充聚氨酯泡沫和聚酯棉。弹簧结构使用弹簧条。四条椅腿使用白蜡木实木制成，并采用鸡翅木色或摩卡色表面处理，末端可以选择小毛毡片或防滑保护垫。表面也可包覆Pelle Frau®皮革或布艺。皮革版本饰有对比色缝线。





## Studio Cerri & Associati

# Donald



### CONCEPT

Pratica eppure elegante, Donald è una sedia pieghevole dalla singolare struttura che ricorda un becco di papero: un arco di compasso in alluminio pressofuso di sezione contenuta, lucido o satinato, che guida e sostiene la seduta e scompare completamente nel suo spessore una volta ripiegata. Disegnata da Studio Cerri & Associati, la sedia pieghevole Donald si presta con grazia ad apparire e scomparire alla bisogna, dando ogni volta una lezione di stile. Nella sedia pieghevole Donald, sedile e schienale sono in materiale termoplastico. Il rivestimento è in Pelle Frau®.

### CONCEPT

Practical yet elegant, Donald is a folding chair made from a single structure that is reminiscent of a duck's beak: a pivoted die-cast limited section aluminium arch, with polished or matt finish, that guides and supports the seat, disappearing completely from view once it is folded. Designed by Studio Cerri & Associati, the Donald folding chair can gracefully appear and disappear on request, each time providing a lesson in style.

The seat and backrest of the Donald folding chair are in thermoplastic material. The upholstery is in Pelle Frau® leather.

### コンセプト

実用的かつエレガント。「Donald」はアヒルのくちばしを彷彿させるユニークな構造を持つ折り畳みチェアです。ダイカストアルミニウム製(光沢仕上げまたはサテン仕上げ)の細いコンパスのアーチが、座面を支えて滑らせ、チェアが折り畳まれると完全に隠れます。

Studio Cerri & Associatiによってデザインされた必要に応じて出し入れ可能な折り畳みチェア「Donald」は、使用する度にそのスタイルをアピールします。

折り畳みチェア「Donald」の座面と背面はサーモプラスチック素材です。カバー材は Pelle Frau®です。

### 理念

Donald既实用又典雅，是一款具有特殊结构的折叠椅，形状好似小鹅嘴：小截面抛光或磨砂压铸铝圆规弧形结构，引导并支撑椅面，折叠之后则完全隐藏。Donald折叠椅由Studio Cerri & Associati设计，能够根据需要优雅地展开或收起，每次都像是一节生动的风格课堂。Donald折叠椅中，椅面和靠背采用热塑材料。覆盖Pelle Frau®软皮。

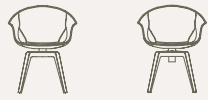

Roberto  
Lazzeroni

# Ginger



## CONCEPT

La poltroncina Ginger, disegnata nel 2011 da Roberto Lazzeroni insieme alla scrivania Fred, ha riscosso fin dal suo apparire un immediato e duraturo successo: ancora oggi resta la seduta più richiesta tra le numerose sedie e poltroncine del catalogo Poltrona Frau. Un tratto nitido, essenziale, di raffinata semplicità, disegna un guscio in pelle accogliente e protettivo. La seduta è estremamente confortevole, le forme sono al tempo stesso sinuose e molto grafiche, assicurando la continuità armoniosa tra scocca e basamento. Pensata sia a naturale completamento della scrivania Fred, sia come seduta autonoma, Ginger è perfetta per la zona studio in versione girevole, ideale attorno al tavolo del soggiorno nella versione fissa.

La struttura della poltroncina Ginger è realizzata in polimero termoplastico composito ottenuto da stampo. L'imbottitura della seduta è in poliuretano espanso. Il rivestimento può essere:

- in Cuoio Saddle Extra per la parte esterna e in Pelle Frau® per la parte interna.
- interamente rivestita in pelle Frau®
- interamente rivestita in tessuto Kvadrat by Poltrona Frau.

## CONCEPT

Designed by Roberto Lazzeroni in 2011 together with the Fred desk, the Ginger armchair has been a success since its debut and remains the most popular of all of the many chairs and armchairs in the Poltrona Frau catalogue. Its clean-cut and unfussy profile, sophisticated in its simplicity, evokes a welcoming and protective leather shell. The seat is extremely comfortable, the forms are both sinuous and highly graphical, guaranteeing harmonious continuity between the shell and the base. Designed as both the natural complement to the Fred desk and as a free-standing seat, the swivel version of Ginger is perfect for the study, while the fixed version is reliable favourite for the dining room.

The structure of the Ginger armchair is made from moulded thermoplastic composite polymer. The seat is padded with polyurethane foam. The upholstery is available in:

- Cuoio Saddle Extra leather for the external surface and Pelle Frau® leather for the internal surface.
- entirely upholstered in Pelle Frau® leather
- entirely upholstered in Kvadrat by Poltrona Frau fabric.

## コンセプト

2011年に机「Fred」と一緒にロベルト・ラッゼローニによって設計されたミニアームチェア「Ginger」は、登場したとたんに大評判となつて、長いあいだ変わらぬ人気を誇っており、Poltrona Frau のカタログ中の数多いすやミニアームチェアの中でもいまだに もっとも需要の高いアイテムです。無駄のないくっきりとしたラインで構成されたレザー製のボディーは、洗練されたシンプルで、座る者をやさしく心地よく包み込んでくれます。座り心地に優れた座面は、カーブであると同時にグラフィックなフォルムで、ボディーとベースの間に調和のとれた連続性が生まれています。「Ginger」は、机「Fred」との組み合わせ、あるいは単独のいすとして考案されており、回転タイプは書斎エリアで、固定タイプはテーブルまわりでの使用が理想的です。

ミニアームチェア「Ginger」の構造は、金型成型による熱可塑性ポリマーで作られています。座面のパッドは発泡ポリウレタン製です。カバー材は以下のバージョンをご用意が可能です。

- 外側はCuoio Saddle Extra、内側はPelle Frau® 製。

## 理念

Ginger小沙发椅，由Roberto Lazzeroni于2011年与Fred写字台一同设计，自面市就立即获得了成功并一直延续：即使到今天，仍然是Poltrona Frau目录中众多座椅和小沙发椅中最受欢迎的一款。清晰、质朴，且考究简洁的线条，勾勒出温馨呵护的软皮外壳。座椅非常舒适，形状既弯曲又极富图形感，确保座体和底座之间和谐的连贯性。Ginger的设计初衷是Fred写字台的天然伴侣，此外也可作为独立座椅，旋转版本完美适合书房，固定版本完美适合起居室餐桌。

Ginger小沙发椅的结构采用冲压成型合成热塑聚酯。坐垫填充聚氨酯泡沫。表面覆盖可为：

- 外側Cuoio Saddle Extra硬皮，内側Pelle Frau®软皮。
- 完全覆盖pelle Frau®。
- 完全覆盖Kvadrat by Poltrona Frau布艺。





La base della poltroncina Ginger è realizzata in legno massello di frassino con supporto di aggancio in acciaio verniciato nero. È disponibile nelle versioni Fissa o Girevole, con meccanismo "torna", che permette la rotazione della poltroncina a 360° e il suo ritorno nella posizione di partenza. Le finiture della base sono frassino tinto Moka o tinto Wengé. Su richiesta, è possibile avere finiture speciali tinte o laccate RAL a campione.

The base of the Ginger armchair is made from solid ash with hook support in black painted steel. It is available in the Fixed or Swivel versions with "return" mechanism which enables the armchair to rotate 360° and return to its starting position. The base is finished in moka or wenge-stained ash. On request, it is possible to have special stains or RAL lacquer finishes based on a sample.

- Pelle Frau®で全体に上張り。  
- Poltrona Frauによってクヴァドラ社のファブリックで全体に上張り。  
ミニアームチェア「Ginger」のベースはトネリコ心材製で、ブラックカラー塗装を施したスチール製連結具のサポート付きです。固定タイプと回転タイプの両バージョンがあり、回転タイプには360°回転させて元の位置に戻す「リターン」機能が搭載されています。ベースの仕上げはモカカラーまたはウエンゲカラーのトネリコ材です。ご要望に応じて、RAL色見本による塗装、特別な色塗装による仕上げも可能です。

Ginger小沙发椅的底座采用白蜡木实木制作，并配以黑色漆面钢钩支撑。有Fissa（固定）或Girevole（旋转）版本可选，后者带有“返回”装置，可将小沙发椅旋转360°，回到初始位置。底座采用摩卡色或鸡翅木色白蜡木饰面。根据要求，可以按照样品制作特殊颜色或RAL色上漆饰面。





# Roberto Lazzeroni

# Ginger Ale

## CONCEPT

La poltroncina Ginger Ale è la variante semplificata e più informale della poltroncina Ginger, seduta di grandissimo successo nel catalogo Poltrona Frau. Comoda, versatile, elegante, la poltroncina Ginger Ale si presta con versatilità sia agli spazi di lavoro, come seduta per singole postazioni o sale riunioni, che agli spazi domestici, per la zona studio o pranzo. Proprio per venire incontro a ogni tipo di esigenza, Roberto Lazzeroni la disegna sia con base metallica verniciata sia con gambe in legno per un totale di cinque basamenti diversi.

Le basi metalliche sono quattro e sono disponibili in due finiture, Cemento e Antracite:

- la base con gambe coniche
- la base a cinque razze con ruote, disponibile sia nella versione girevole 360° ad altezza fissa, sia nella versione con molla a gas per la regolazione dell'altezza seduta. Le ruote sono piroettanti autofrenanti morbide, con supporto in plastica nera per le versioni verniciate.
- la base a quattro razze
- la base con colonna, sia in versione fissa sia girevole, con dispositivo ammortizzatore e rientro automatico al punto di partenza.

## CONCEPT

The Ginger Ale armchair is a simplified and more informal version of the Ginger armchair, one of the most successful chairs in the Poltrona Frau catalogue. Comfortable, versatile and elegant, the Ginger Ale armchair lends itself both to workspaces, individual workstations or meeting rooms, as well as domestic settings, such as the study or dining room. With the specific aim of catering for all needs, Roberto Lazzeroni designed it with both a painted metal base and with wooden legs, allowing for a total of five different bases. There are four metal bases which are available in two finishes, Cemento and Antracite:

- base with conical legs
- 5-spoke base with castors, available in both the 360° swivel version with fixed height and version with height-adjustable gas spring. The wheels are soft self-braking swivel castors with black plastic support for the painted versions.
- four-spoke base
- base with column, in both the fixed and swivel versions, with shock absorbing device and automatic return to the starting position.

## コンセプト

ミニアームチェア「Ginger Ale」は、A Poltrona Frauのカタログ中でも大人気のいすであるミニアームチェア「Ginger」のシンプルでインフォーマルなバージョンです。快適で、多様性に富み、エレガントなミニアームチェア「Ginger Ale」は、職場では、各人の席や会議

室用に、ご家庭内の空間々では書斎、食事エリア用に、多様なニーズに応えます。ロベルト・ラッゼロは、あらゆるニーズに対応するために、金属ベース塗装バージョン、木製脚付きバージョンなど、5種類のベース・バージョンをデザインしました。金属ベースは以下の4種類で、それぞれセメントカラー仕上げと無煙炭カラー仕上げの2バージョンをご用意できます。

- 円錐脚付きのベース  
- 5本スポーク式タイヤ型ベースは、固定高で360°回転バージョンと、A座面高調節用のガス式スプリングが付いたバージョンがあります。ビルエットタイヤはソフトセルフロック式で、ビルエット式タイヤで、塗装バージョンにはブラックカラーのプラスチック製サポートが付いています。  
- 4本スポーク式ベース。  
- 円柱ベースは、固定タイプも回転タイプも、ショックアブソーバー機能と自動的に元の位置に戻るオートリターン機能が搭載されています。

## 理念

Ginger Ale小沙发椅是Ginger小沙发椅 - Poltrona Frau样本中一款获得巨大成功的座椅 - 的简化和非正式版本。舒适、灵活、典雅，Ginger Ale小沙发椅既可灵活适应工作空间，当作单独座椅或会议室座椅，也可适应家居空间，在书房或餐厅使用。正是为了满足各种需求，Roberto Lazzeroni为其设计了总共五种不同的底座，包括漆面金属底座和木制椅腿。金属基底有四款，有两种饰面可供选择：Cemento（混凝土色）和Antracite（无烟煤色）：  
- 带有锥形椅腿的底座  
- 五支爪轮底座，分为固定高度360° 旋转款和座垫高度可调的空气弹簧款。自转轮带有柔和的自制动装置，漆面版本配有黑色塑料支撑。  
- 四支爪底座  
- 带立柱底座，可以为固定或旋转版本，带有缓冲装置，自动回到初始点。





Oltre ai quattro basamenti in metallo, Ginger è disponibile anche con quattro gambe in massello di frassino a sezione triangolare, disponibile nelle finiture tinto Moka o tinto Wengé, tinto a campione o laccato RAL a campione.

As well as the four metal bases, Ginger Ale is also available with four triangular-profile solid ash legs, available with moka or wenge-stained finishes, stained according to sample or with RAL lacquer based on a sample.

「Ginger Ale」は、この4種類の金属脚以外に、三角断面のトネリコ心材製の脚4本タイプがあり、モカカラー、ウェンゲーカラー、色見本、RAL色見本による塗装仕上げでのご用意が可能です。

除了四种金属底座外，GingerAle还提供白蜡木实木三角形截面四椅腿版本，有摩卡色或鸡翅木色表面可选，另外还可根据样品上色或根据样品进行RAL色上漆。







La scocca della poltroncina Ginger Ale è realizzata in polimero termoplastico composito ottenuto da stampo e imbottita in poliuretano espanso. È disponibile:

- verniciata colore Antracite
- verniciata colore Cemento
- interamente rivestita in Pelle Frau®
- interamente rivestita in tessuto Kvadrat by Poltrona Frau.

The shell of the Ginger Ale armchair is made from moulded thermoplastic composite polymer and padded with polyurethane foam. It is available:

- painted in anthracite colour (Antracite) - painted in cement colour (Cemento) - entirely upholstered in Pelle Frau® leather - entirely upholstered in Kvadrat by Poltrona Frau fabric.

ミニアームチェア「Ginger Ale」のボディーは金型成型による熱塑性型ポリマ一製で、発泡ポリウレタンのパッド材を使用しています。以下の4バージョンのご用意が可能です。

- 無煙炭カラー塗装
- セメントカラー塗装
- Pelle Frau®で全体を上張り
- Poltrona Frauがクヴァドラ社ファブリックで全体を上張り。

Ginger Ale 小扶手椅主体采用印压成型合成热塑聚?酯制作，填充聚氨基酯泡沫。提供：

- Antracite（无烟煤）色漆面
- Cemento（混凝土）色漆面
- 完全覆盖Pelle Frau® SC软皮。
- 完全覆盖Kvadrat by Poltrona Frau布艺。

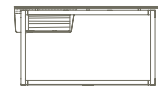

Fred — 334

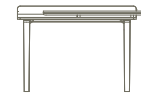

Iren — 336



Mesa Due — 340

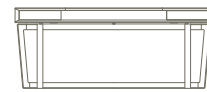

Peek-a-Book — 344

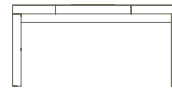

Segreto — 350

Home-Office Collection  
Poltrona Frau

# Tables and Desks

Fred — Iren — Mesa Due  
Peek-a-Book — Segreto



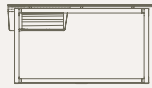

## Roberto Lazzeroni

# Fred



### CONCEPT

Il design della scrivania Fred è un incontro di geometrie leggere, quasi aeree. Roberto Lazzeroni crea un mobile dove il piacere visivo di una superficie continua in cuoio è sottolineato da delicate incisioni e marcature a freddo eseguite a mano, che creano raffinati decori grafici. Un particolare procedimento artigianale permette di ottenere la curvatura frontale del cuoio senza necessità di supporti interni. Compagna ideale della scrivania Fred è la seduta Ginger, progettata per rendere ancora più completa e armoniosa la zona studio della casa.

La struttura della scrivania Fred è in legno massello di frassino tinto wengé o moka, con profilo a sezione triangolare che ne esalta la leggerezza. Stesso materiale e finiture anche per il cassetto che completa la scrivania, montato su guide metalliche con chiusura ammortizzata. Il piano è in Cuoio Saddle Extra ricavato in un unico manto di cuoio spesso 4 mm senza divisioni o cuciture. Il bordo a taglio netto è rifinito con tinta e cera protettiva. Accessori in metallo con trattamento galvanico canna di fucile e vernice protettiva.

### CONCEPT

The Fred desk is a meeting of light, almost ethereal geometries. Roberto Lazzeroni creates a piece of furniture in which the visual pleasure of a continuous saddle-leather surface is underlined by delicate hand-produced incisions and cold markings that create refined graphic decorations. A special procedure makes it possible to curve the front of the saddle-leather without any need for internal supports. The ideal companion of the Fred desk is the Ginger chair, designed to make the study even more complete and harmonious. The structure of the Fred desk is made from solid ash with a wenge or moka stain and triangular cross-section, which highlights its lightness. Same material and finishes also for the drawer that completes the desk, mounted on metal runners with soft closing mechanism. The surface is covered using a single piece of 4 mm-thick Cuoio Saddle Extra leather without any divisions or stitching. The raw edge seam is finished with protective wax and dye. Metal accessories with gunmetal grey galvanic treatment and protective varnish.

### コンセプト

デスク「Fred」のデザインのコンセプトはまるで宙に浮いているような軽快な形状の集まりです。ロベルト・ラッゼローニのこの作品では、なめし革の表面がずっと続いて、心地よい視覚効果が、洗練された模様を生み出す手作業で施された繊細なエンボス

加工とコールドマーキングを際立たせています。クラフトマンシップの特殊な工程によって、内側から補強せずになめし革の表面を湾曲させることが可能になりました。デスク「Fred」の理想的な相棒はご自宅の書斎エリアをより完全にバランスよく演出するためにデザインされたアームチェア「Ginger」です。デスク「Fred」の構造にはウエンゲ

カラーまたはモカカラーに染色されたトネリコ心材が使用されており、三角形的の断面が軽やかさを際立たせています。ソフトクローズ機能を持つ金属ガイド上に取り付けられたデスクの引き出しも、同じ素材と仕上げで統一されています。天板は切れ目や繋ぎ目の一切ない厚さ4mmの1枚革のCuoio Saddle Extraを使用しています。縁はクリーンカットされ、端引き表面保護処理が施されています。金属の付属品は、保護塗装されたガンメタルカラー亜鉛めっき加工を使用。

### 理念

Fred写字台的设计是几近空灵的轻盈几何形状的交汇。Roberto Lazzeroni设计的这款家具中，以细腻的镌刻和手工冷印彰显皮革连续表面的视觉愉悦感，打造精致的图形装饰。特殊手工工艺实现皮革前表面弯曲度，而无需内部支撑。Fred写字台的理想伴侣是Ginger座椅，令家庭书房更加完备、和谐。

Fred写字台结构使用鸡翅木色或摩卡色柁木实木，具有三角形截面，彰显轻盈感。构成写字台的抽屉也使用相同的材料和表面处理，安装在金属导轨上，使用缓冲开闭系统。桌面使用来自整张牛皮的Cuoio Saddle Extra皮革，厚度4毫米，无切割或缝线。边缘剪裁整齐，染色并涂有保护蜡。金属配件采用枪管色电镀处理，涂有保护漆料。

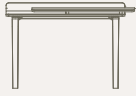

## Kensaku Oshiro

# Iren



### CONCEPT

Nel mondo della calligrafia giapponese c'è un'invisibile, ma cosciente, continuità fra punti, linee e caratteri, chiamato "iren" (意連). Questa continuità nei gesti fa sì che i segni siano in perfetta armonia fra loro nonostante sembrano divisi. Anche in un'era come la nostra, così dominata dalla tecnologia, la scrivania Iren ha come spirito non solo la ricerca della bellezza e dell'essenzialità, ma soprattutto il recupero del gesto naturale e armonioso: uno scrittoio che dà vita a nuovi scenari e rituali del lavorare, in un rapporto di naturale fluidità fra il corpo e l'oggetto. Il designer Kensaku Oshiro ha immaginato la scrivania Iren come una piccola postazione domestica in grado di adattarsi agilmente allo stile di vita moderno. Grazie a un semplice gesto, due piani sovrapposti scorrono uno sull'altro creando nuovi spazi di lavoro e di contenimento. La bellezza dello scrittore non è intaccata dai collegamenti elettronici: la predisposizione per la ricarica e le prese USB sono alloggiata in una scatola nera metallica sulla quale poggia il piano superiore, avvolto in un elegante rivestimento in pelle o cuoio. Il ripiano superiore si inclina gentilmente per una sensazione più morbida e un miglior sostegno degli avambracci. La versione a muro può montare sul retro un'illuminazione a led, per rendere più agevole la fruizione della scrivania in condizioni di scarsa luce ambientale.

### CONCEPT

In the world of Japanese calligraphy there is an invisible but deliberate continuity between points, lines and characters called "iren" (意連). This continuous motion ensures that there is a perfect harmony between the symbols even though they appear divided. Even in an era like ours, so dominated by technology, the spirit of the Iren desk lies not only in its quest for beauty and simplicity but above all in its revival of a natural and harmonious action: a desk that gives rise to new work scenarios and rituals in a naturally fluid relationship between body and object. Designer Kensaku Oshiro envisaged the Iren desk as a small domestic workstation that easily adapts to modern lifestyles. Thanks to a simple motion, two overlapping surfaces slide over each other to create new work and storage spaces. The beauty of the desk is not diminished by its electronic connections: its recharging and USB points are located in a metallic black box that supports the upper surface, wrapped in an elegant leather or saddle-leather cover. The gently sloping upper surface ensures a softer feel while also providing better support for the forearms. The wall version can have an LED light fitted at the back so the desk can be used when the natural light starts to dim.

### コンセプト

日本の書道の世界には『意連』と呼ばれる連続する点と線、文字と文字との間に存在する目に見えない意識的な連なりがあります。ジェスチャーにおけるこの連なりはそれぞれ異なって見える点や線の間に完璧な調和を醸し出します。これほどテクノロジーに

支配された我々の時代でもライティングデスク『Iren』には美と本質を追求する精神に溢れているだけでなく、とり

わけ自然で調和の取れたジェスチャーの回復:すなわち、身体と物体の間にある自然な流動性の中で仕事の新しい環境と慣習に息を吹き込むデスクです。デザイナーの大城健作は現代のライフスタイルに順応できる家庭の小さなホームステーションとしてライティングデスク『Iren』をイメージしました。単純なジェスチャーで重なり合う2枚の台が上下にスライドし、新たな作業/収納スペースを作り出します。デスクの美しさが電気接続によって損なわれることはありません。チャージャーとUSBポートはレザーまたはなめし皮でエレガントにコーティングされた上部天板を支える金属製のブラックボックスに格納されています。やや傾斜した上部天板がよりソフトな感覚を与え、前腕を最良のポジションで支えます。壁際に置くバージョンでは、周囲光条件があまり良くなっても、より快適にデスクを使用できるよう、裏面にLED照明を取り付けることも可能です。

### 理念

在日本书法界，点、线、字之间存在一种看不见但有意识的连续性，被称为“iren”（意连）。姿态之间的这些连续性使得它们之间似乎分离、但却能和谐共处。即使在我们这个时代——也就是由技术主导的时代，Iren写字台的精髓不只在于对美丽和精简的追求，更在于恢复自然而和谐的姿态：这个写字台为工作中的新场景与新习惯赋予生命，符合身体与物品之间的自然流畅关系。设计师大城健作将Iren写字台想象成一个小家用工作台，能够轻松适应现代生活方式。只需简单操作便可让两个重叠台面中的一个在另一个之上滑动，带来新的工作和容纳空间。写字台的美感没有受到电子连接的影响：充电和USB插座位于黑色金属盒中，盒上是上层台面，表面覆盖优雅的软皮或硬皮。上层隔板略微倾斜，带来更加柔和的感觉，并能够为前臂提供更好的支撑。对于壁挂式，可在背面安装LED照明灯，以便在环境光线不足时也能更好使用写字台。



Poltrona Frau realizza la scrivania Iren nelle versioni free-standing, con il piano che appoggia su una base a cavalletto in massello di frassino, o a muro, montato a staffe. Lo scorrimento a destra oppure a sinistra è a scelta del cliente al momento dell'ordine.

Il piano utile della scrivania Iren passa da 119 a 149 cm al momento della completa apertura del piano scorrevole. Le parti a vista in legno sono in frassino, disponibile nelle finiture tinto Wengé o tinto Moka. Il rivestimento dei piani può essere in pelle o in cuoio con cuciture perimetrali tono su tono o a contrasto. Il marchio Poltrona Frau è impresso in basso a destra sul piano scorrevole.

The Iren desk by Poltrona Frau comes in a free-standing version, with the desktop supported by a sawhorse base in solid ash, or a wall-mounted version, supported by brackets. The customer can choose whether the desktop slides left or right when making their order.

The work surface of the Iren desk increases from 119 cm to 149 cm when the sliding top is completely open. The visible wooden parts are in ash in either a Moka or Wenge stain. The desktops can be upholstered in leather or saddle-leather with tone-on-tone or contrast stitching around the edges. The Poltrona Frau logo is branded on the bottom right of the sliding surface.

Poltrona Frauは自立式Irenを実現しました。このバージョンのデスクでは天板はトネリコ心材のイーゼル風ベースによって支えられているか、スターラップによって壁に直接取り付けられます。スライド方向(右または左)はお客様が注文時に選択出来ます。

スライド式天板を完全に引き出すとデスク『Iren』の使用可能な表面は119cmから149cmになります。見える部分の木製パーツにはトネリコ心材が使用されており、モカカラー仕上げとウエンゲーカラー仕上げの2タイプがあります。天板のカバー材は同系色または反対色のステッチで縁取りされたレザーまたはなめし皮です。Poltrona Frauのロゴはスライド式天板の左下に刻まれています。

Poltrona Frau提供独立式Iren写字台，其台面架在画架式白蜡木实木基座上，也提供壁挂式，安装在销杆上。订购时，客户可以选择向左或向右滑动。

当滑动台面完全打开时，Iren写字台可用台面长度从119cm增加到149cm。外露木材部分使用白蜡木，分为鸡翅木色或摩卡色表面处理。台面可以表面覆盖软皮或硬皮，周围使用同色深浅或对比色缝线。滑动台面下方右侧烙印Poltrona Frau商标。



## Lella and Massimo Vignelli

# Mesa Due



### CONCEPT

Poltrona Frau ha svolto un interessante lavoro filologico attorno al progetto Mesa: sulla base di alcuni disegni originali firmati da Lella e Massimo Vignelli, sono state realizzate alcune versioni inedite del tavolo originario, denominate appunto, Mesa Due.

Due come le semplici forme geometriche, un cerchio e un cono, accostate fra loro a formare un tavolo di grande personalità e forte segno grafico.

Accanto al modello di tavolo Mesa con piano in ardesia e colonna portante in pietra serena, prendono forma altre dimensioni che ampliano i possibili utilizzi e sfociano nei modelli Mesa Due: il tavolo bistrot di diametro 120 cm, il tavolo da pranzo di diametro 150 o 180 cm e il tavolo rettangolare da 260x110

Il piano è disponibile in numerose versioni che spaziano dal legno, fino alla pelle e al marmo. Le versioni in legno sono impiallacciate in tranciato di frassino con finitura tinto Moka o Wengé. I tavoli tondi da 120 e 150 cm possono essere anche rivestiti in Pelle Frau® SC. In questo caso il piano è realizzato con doppia pannellatura a bordo smussato. La parte inferiore è verniciata nera testurizzata, quella superiore è rivestita in pelle. A eccezione del tavolo bistrot, tutti gli altri modelli possono montare un top in marmo Calacatta Oro o Fior di Pesco, nelle finiture lucido e semi-lucido.

### CONCEPT

Poltrona Frau has carried out an interesting philological work on the Mesa project: on the basis of a number of original designs by Lella and Massimo Vignelli, it has created a number of new versions of the original table, calling them, fittingly, Mesa Due. Due - two - like its simple geometric shapes, a circle and a cone, combined together to form a table bursting with personality and style.

The Mesa table model with slate top and load bearing column in pietra serena is joined by new sizes that offer a greater variety of possible uses: the Mesa Due model comes as a bistro table with diameter of 120 cm, a dining table with diameter of 150 or 180 cm, and a rectangular table measuring 260 x 110.

The top is available in numerous versions ranging from wood to leather and through to marble. The wood versions are veneered in cut ash wood with moka or wenge stain finish. The 120 and 150 cm round tables can also be upholstered with Pelle Frau® SC leather. In this case the top is made from double panelling with tapered edge. The bottom part is finished with texturised black paint, the top part upholstered in leather. With the exception of the bistro table, all of the other models can be fitted with a Calacatta gold or Fior di Pesco marble top with polished or semi-polished finish.

### コンセプト

Poltrona Frauはプロジェクト「Mesa」を通して興味深い哲学的な作品を制作しました: レッラ& マッシモ・ヴィニェリによるオリジナルのデザインを元に実現された独創的な新作テーブルは、「Mesa Due」と命名されました。円と円錐という2つのシンプルな幾何学的形状を組み合わせることで、グラフィック的効果の強い、非常に個性的なテーブルを創り上げています。

スレート製天板とセレーナ石の支柱で構成されたテーブル「Mesa」に加え、より幅広い用途を提案するサイズの異なるモデル「Mesa Due」: 直径150 cmまたは180cmのビストロテーブルと長方形のテーブル(260 x 110 cm)が揃っています。

天板は木材、レザー、大理石まで数多くのバージョンからお選びいただけます。木製バージョンはトネリコ合板で化粧張りされ、ウエンゲーカーまたはモカカラーに染色されています。直径120-150 cmの円形テーブルはPelle Frau® SCでコーティングすることも可能です。この場合、天板は周縁が丸く加工されたダブルパネルで形成されています。下面はテクスチャードブラックで塗装され、上面はレザーでコーティングされています。ビストロテーブル以外の全てのモデルは、光沢仕上げ、または半光沢仕上げの大理石製トップ(「Calacatta Oro」大理石または「Fior di Pesco」大理石)を取り付けることができます。

### 理念

Poltrona Frau圍繞Mesa專案展開了一項有趣的語義學工作: 在Lella和Massimo Vignelli設計的原始圖紙基礎上, 製作出幾款前所未有的原創餐桌, 命名為Mesa Due。兩個簡單的幾何形狀, 一個圓環, 一個圓錐, 互相結合, 構成極具個性、具有強烈個性和圖形符號表現的桌子。

Mesa桌款式使用板岩桌面和塞茵那石支柱, 此外還有其它尺寸, 擴展用途, 並發展為Mesa Due款式: 直徑120釐米的餐吧咖啡桌、直徑150釐米或180釐米的午餐桌和260x110釐米的餐桌。

檯面從木質到皮革, 再到大理石, 有多種版本可選。木質檯面版本採用摩卡色或雞翅木色白蠟木片貼面。120和150釐米圓桌也可包覆Pelle Frau® SC軟皮。在這種情況下, 檯面由雙鑲板製作, 邊緣修圓。下部為黑色紋理漆面, 上部包覆軟皮。除了餐吧咖啡桌, 所有其他款式均



Il tavolo tondo da 180 cm può essere accessoriatato con un piano girevole Lazy Susan, composto dall'assemblaggio di due piani rotondi di diametro diverso. Tra i due piani è alloggiato un meccanismo in alluminio girevole su sfere d'acciaio.

La base del tavolo Mesa Due può essere in pietra serena di colore grigio o in acciaio con rivestimento in Cuoio Saddle Extra con cuciture a contrasto o in Pelle Frau® ColorSphere® con cuciture tono su tono. La base in acciaio mantiene la stabilità grazie a uno speciale sistema di contrappesi interni, e dispone di un puntale sagomato in plastica all'estremità, a protezione del pavimento. Il raccordo tra piano e colonna è in tubolare di acciaio verniciato nero su cui poggia una crociera a tre bracci dotati di supporti regolabili per il livellamento del top.

Nel tavolo rettangolare, le colonne di appoggio sono due, con le crociere a tre braccia. Solo per i tavoli tondi da 150 e 180 con top in marmo è previsto un sostegno maggiorato con una crociera a cinque bracci. I tavoli Mesa Due con colonna in pelle o cuoio e top in legno o rivestito in Pelle Frau® possono essere predisposti con una torretta a scomparsa elettrificata, scelta e specificata dal cliente in fase di acquisto.

The 180 cm round table can be assembled with a Lazy Susan consisting of two round tops of different diameters. In this case an aluminium swivel mechanism on steel spheres is fitted between the two surfaces.

The base of the Mesa Due table can be in grey pietra serena or in steel with upholstery in Cuoio Saddle Extra leather with contrast stitching or Pelle Frau® ColorSphere® with tone-on-tone stitching. The steel base maintains its stability through a special system of internal counterweights and has a plastic shaped tip at the bottom to protect the floor. The joint between the top and the column is made of black painted tubular steel to which a three-bracket joint plate is attached with adjustable supports to keep the surface level. In the rectangular table there are two supporting columns and the joint plates have 3 brackets. Only in the round 150 and 180 cm tables with marble top is there a larger support with five-bracket joint plate. The Mesa Due tables with leather or saddle leather column and top in wood or upholstered in Pelle Frau® leather can come with a hideaway electric socket tower, chosen and requested by the customer upon purchase.

180 cmの円形テーブルには、直径の異なる2枚の円形トップから成る回転式天板「LazySusan」を取り付けることができます。両天板の間にはスラストベアリングに取り付けられたアルミニウム製機構が搭載されています。

Mesa Dueのベースはグレーのセレーナ石、あるいはなめし皮Saddle Extra(ステッチは反対色)かPelle Frau® ColorSphere®(ステッチは同系色)でコーティングされたスチール製のいずれかのバージョンが可能です。スチール製ベースは内側の特殊なカウンターウェイトシステムによって安定性を維持することが出来ます。また床を保護する成形プラスチック製先端が付いています。天板と支柱の連結部はブラック塗装されたスチールパイプ製で、この上に天板を水平に保つための調節式サポートが付いたクロス式3本アームが挟まれています。長方形テーブルの支柱は2本で、クロス式3本アームが備わっています。天板が大理石製の直径150-180 cmの円形テーブルのみ、クロス式5本アームで補強されています。支柱が革張り/なめし皮張りタイプで、天板が木製またはPelle Frau®でコーティングされたテーブル「Mesa Due」は、購入時にお客様から特別に指定があれば、収納式電化小塔を搭載することが可能です。

可安裝卡拉卡塔金大理石或帕斯高灰大理石檯面，可為亮面或半亮面表面處理。180釐米圓桌可配備Lazy Susan餐桌轉盤，由直徑不同的兩個圓形平面組裝構成。在兩個平面之間帶有一個鋁制裝置，可在鋼球上旋轉。

Mesa Due桌的基座可以為灰色塞茵那石或鋼材，後者覆蓋Cuoio Saddle Extra革並使用對比色縫線，或Pelle Frau®ColorSphere®軟皮並使用同色深淺縫線。鋼制底座通過特殊的內部配重系統保持穩定性，端部具有塑膠成形墊腳，以保護地板。桌面和支柱之間的連接為黑漆鋼管，支撐一個三臂交叉支杆，配有桌面高度調節支架。方桌帶有兩個支柱，配以三臂交叉支杆。僅對於大理石檯面的150和180釐米圓桌，配有五臂交叉支杆的更牢固支撐。

帶有軟皮或硬皮支柱且檯面為木質或包覆Pelle Frau®軟皮的Mesa Due桌，可以安裝電動沉降式插座，由客戶在購買時選擇和指定。

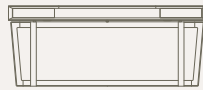

Roberto  
Lazzeroni

# Peek-a-Book



## CONCEPT

La scrivania Peek-a-Book, disegnata da Roberto Lazzeroni, riassume in sé tutte le caratteristiche di eleganza e comfort tipiche di un ufficio Poltrona Frau, trasportandole in ambito domestico. Lazzeroni immagina un piano di dimensioni generose e un design che si sviluppa in continuità con i materiali, il calore e il linguaggio delle sue collezioni per il residenziale, senza però rinunciare a tutte le funzionalità di una "vera" scrivania da ufficio.

La scrivania Peek-a-Book è costituita da un semplicissimo foglio in legno multistrato di pioppo rivestito in Pelle Frau®, curvato e piegato in due a formare il fondo e il piano di scrittura, nonché a racchiudere al suo interno i due cassetti. L'effetto visivo è quello di un prezioso libro rilegato in pelle, che simboleggia la funzione stessa dell'oggetto: la scrivania è infatti il luogo deputato a produrre e a raccogliere le idee, i pensieri, i ricordi; la parte più intima e personale di chi vi studia o lavora.

## CONCEPT

Designed by Roberto Lazzeroni, the Peek-a-Book desk embodies all of the typical elegance and comfort of a Poltrona Frau office, ushering it into the domestic setting. Lazzeroni envisages a generous work surface and a design that revisits the materials, warmth and style of his residential collections while at the same time guaranteeing all of the functions of a "genuine" office desk.

The Peek-a-Book desk consists of an extremely simple sheet of poplar plywood covered in Pelle Frau® leather which is curved and folded in two to form the base and the desktop, as well as to accommodate two drawers. The visual effect is that of a valuable leather-bound book that symbolises the function of the object. In fact, the desk is a place for thinking, collecting our thoughts and looking back over our memories: the most intimate and personal side of the person that uses it to study or work.

## コンセプト

ロベルト・ラッゼローニのデザインによるデスク「Peek-a-Book」は、Poltrona Frauのオフィス製品を特長づけるエレガンスとコンフォートの全てをご家庭にもたらしめます。ラッゼローニがイメージしているのは、ゆったりとした天板を使用したサイズ展開で

あり、オフィス用の「本物」のデスクの機能性を100%維持したまま、自身の家庭用コレクションの素材、熱意、表現法と連関して発達していけるようなデザインです。

デスク「Peek-a-Book」は、Pelle Frau®で上張りしたシンプルなセイヨウハコヤナギの積層板をたわめ、2つに折り曲げて、2段のドロワーが付いた、底部と物を書くためのデスク面を形成しています。レザー装丁の貴重本のようなこの視覚効果は、デスクの機能自体の象徴ともいえます。つまり、デスクとは、事実、アイデア、思考、思い出を生み出し、集積するための場所であり、学ぶ者、働く者にとってもっともプライベートで個人的な場所なのです。

## 理念

由Roberto Lazzeroni设计的Peek-a-Book写字台，汇集了Poltrona Frau办公室典型的优雅和舒适特征，并将其应用到家居环境中。Lazzeroni设想了一个宽大的台面，并且其设计可随着家居系列材料、色度和风格的变化不断发展，但绝不忽视一部“真正”办公桌所应具备的任何功能。

Peek-a-Book写字台由一块非常简单的杨木胶合板薄板组成，覆盖PelleFrau®软皮，弯曲并折叠为两部分，形成底板和写字板，并在中间加入了两个抽屉。视觉效果如同一本用皮革装订的珍贵书籍，象征着这款家具的功能：实际上，办公桌是专门用来产生和收集创意、思想和记忆的地方；对于用其进行学习或工作的人来说，这是最亲密和最私人的部分。





La struttura della base è costituita da un cavalletto in massello di frassino tinto Moka o Wengé a sezione triangolare, che forma tre perimetri a forma di trapezio collegati tra loro da preziosi raccordi lavorati nel legno. Il frontale dei due cassetti è in MDF rivestito in Pelle Frau® abbinata al rivestimento del piano, mentre la struttura interna è realizzata in legno massello di frassino tinto Moka. Il rivestimento del piano, del frontale cassetti, delle pareti laterali e degli sportelli di accesso ai vani posteriori è in Pelle Frau® ColorSphere. Il rivestimento del piano è realizzato mediante una particolare tecnica di ri-

The base structure consists of an easel made from triangular-section solid ash in a moka or wenge stain which forms three trapezium-shaped supports connected to each other with fine joints created in the wood. The front of the two drawers is in MDF covered in Pelle Frau® leather matching the upholstery of the top, while the internal structure is made from solid ash in a wenge stain. The upholstery of the top, the front of the drawers, the side walls and the doors accessing the rear compartments is in Pelle Frau® ColorSphere. The upholstery of the top is produced using a particular covering technique without any visible stitching.

ベース構造は、断面が三角形のモカカラーまたはウェンゲーカラーのトネリコ心材製の架台で作られており、これが凝った木工細工の連結具で繋がれた台形の3辺を形成しています。ドローワー2段の前面は、天板の上張りにマッチングするPelle Frau®で上張りされた中密度繊維板製で、内部構造はウェンゲーカラーのトネリコ心材で形成されています。天板、ドローワーの前面、側板、後部スペースへのアクセスドアは、Pelle Frau® ColorSphereで上張りされています。天板の上張りは、特殊なカバー技術を使って、ステッチが全く見えないように仕上げられています。

底座的结构由一个摩卡色或鸡翅木色的三角形截面实心白蜡木台架构成，形成三个梯形周边，并彼此用木材加工而成的精美接头连接在一起。两个抽屉的面板为中密度纤维板，采用与台面覆面相搭配的PelleFrau®软皮覆盖，内部结构则用鸡翅木色的实心白蜡木制成。台面、抽屉面板、侧壁和后部隔间的小门均采用Pelle Frau® ColorSphere软皮覆盖。台面覆面采用特殊的贴面技术制作，没有任何可见的缝线。

在两个中央抽屉的后部，Peek-a-Book写字台配有两个侧门，掩盖了缝隙。隔间专为走线所设计，可用于放置插座，





copertura, senza alcun filo di cucitura a vista.

Dietro ai due cassetti centrali, la scrivania Peek-a-Book è dotata di due sportelli laterali che celano un'intercapedine. I vani sono predisposti per il passaggio cavi e possono essere utilizzati per alloggiare i multipresa oppure per cablaggio elettrico con Schuko o USB.

È possibile anche installare un dispositivo di ricarica a induzione per smartphone sotto il rivestimento in pelle del ripiano, evidenziato da un logo impresso a caldo.

Behind the two central drawers, the Peek-a-Book desk has two side flaps that conceal a hollow space. The compartments are designed to act as a conduit for cables and can be used to house multi-sockets or electric cables with Schuko or USB.

It is also possible to install a smartphone induction charger under the leather upholstery of the desktop, as suggested by the branded logo.

「Peek-a-Book」では、中央のドロワー2段の後ろにサイドドア2枚が付いた隠しスペースがあります。このスペースはケーブル配線用にあらかじめ配置されているもので、マルチソケットやSchukoタイプのプラグ、USBなどの収納に使用できます。また、棚板のレザー製上張りの下にスマートフォンの充電装置を取り付けることも可能で、熱刻印されたロゴが場所の目印になっています。

或Schuko插头或USB的布线。还可以在烫印有徽标的层板皮革覆面下安装智能手机感应充电装置。



Andr e  
Putman

# Segreto



## CONCEPT

Andr e Putman disegna una versione contemporanea dello scrittoio da casa. La scrivania Segreto   un mobile dalle linee asciutte ed essenziali e dalle proporzioni eleganti, che rivela una serie di cassetti portaoggetti ricavati nello spessore del piano. A scomparsa anche il cassetto verticale integrato in uno dei due sostegni e corredato di tasche a soffi to in pelle. Sono previsti anche appositi vani per il passaggio dei cavi all'interno dello scrittoio.

La struttura della scrivania Segreto   realizzata in MDF con rinforzi in massello di faggio, e laccata con vernice goffrata antigraffio nei colori latte o grafite. I cassetti sono in MDF, inseriti nello spessore del piano, con fondo rivestito in pelle. La parte superiore della scrivania Segreto e le parti anteriori delle tasche sono imbottite in poliuretano espanso e rivestite in pelle. Il piano dello scrittoio, i cassetti e gli accessori sono tutti rivestiti in Pelle Frau .

## CONCEPT

Andr e Putman designs a contemporary version of the household desk. The Segreto desk is a piece of furniture with clean, simple lines and elegant proportions that reveals a series of drawers built into the desktop. The vertical drawer built into one of the two legs and furnished with leather bellows pockets is also concealed. There are also various compartments for passing cables into the desk.

The structure of the Segreto desk is made from MDF with reinforcements in solid beech and lacquered with scratchproof textured paint in the colours milk or graphite. The drawers are in MDF, inserted in the desktop, with bottoms upholstered in leather. The upper part of the Segreto desk and the front parts of the pockets are padded in polyurethane foam and upholstered in leather. The desktop, drawers and accessories are all upholstered in Pelle Frau  leather.

## コンセプト

アンドレ・プットマンがコンテンポラリーバージョンの自宅用デスクをデザインしました。無駄のないクリーンなラインとエレガントなバランスを持つデスク「Segreto」は、天板の厚みに収まった一列の小物用引き出しが特徴です。デスクを支える一方の脚にはレザー製の折り畳み式ポケットが備わった縦長の引き出しも内蔵されています。デスク内はコード類を通せる構造になっています。

デスク「Segreto」の構造体はブナ心材で補強されたMDFで作られており、アンチスクラッチエンボス塗装ラッカー仕上げが施されています。色はミルクかグラファイトです。天板の厚み内に挿入された引き出しはMDF製で、底部は革張りです。デスク「Segreto」の上部とポケット前部は発泡ポリウレタンのパッドが挿入され、レザーコーティングされています。デスク天板、引き出し、アクセサリ類は全てPelle Frau で覆われています。

## 理念

Andr e Putman 设计出家庭书桌的当代版本。Segreto 写字台是一个线条简单精炼、比例典雅的家具，在桌面中配有系列置物抽屉。两个支脚之一内部也整合有沉降式抽屉，搭配软皮风箱袋。书桌内部也为布线准备了专门的空间。

Segreto 写字台结构采用中密度纤维板，通过榉木实木加固，喷涂奶白色或石墨色防划压花漆料。抽屉使用中密度纤维板，推入桌面，底面覆盖软皮。Segreto 写字台前侧以及风箱袋前部分均填充聚氨酯泡沫并覆盖软皮。书桌桌面、抽屉和配件全部覆盖 Pelle Frau  软皮。



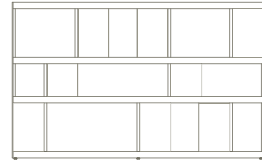

Jobs Bookcase — 354

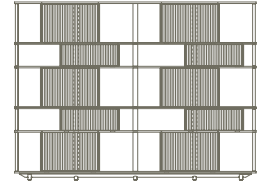

Lloyd — 358



Ren Bookcase — 362

Home-Office Collection  
Poltrona Frau

# Bookcases

Jobs Bookcase — Lloyd — Ren



Rodolfo  
Dordoni

355

# Jobs Bookcase

## CONCEPT

La libreria Jobs Bookcase nasce da un attento studio di Rodolfo Dordoni sull'evoluzione dei comportamenti in relazione alle nuove tecnologie e da un'accurata selezione dei materiali: pelle, legni lucidi e opachi e strutture in acciaio satinato arricchiscono in tono sobrio ed essenziale i differenti volumi. Le librerie Jobs Bookcase sono contenitore e libreria insieme, alternano vani a giorno, mensole e vani con ante. Da parete o centro stanza, sono utilizzabili anche per definire, dividere e organizzare gli spazi. Le due tipologie si differenziano per la disposizione degli elementi e dei divisori verticali che, nella variante da parete, sono tutti più arretrati e permettono di ottimizzare gli spazi.

## CONCEPT

The Jobs Bookcase collection is the result of Rodolfo Dordoni's close study of the evolution of behaviour in relation to new technologies and the careful selection of materials: leather, shiny and matt woods and structures in brushed steel enrich the different volumes in a simple, understated way to create new work areas. The Jobs Bookcase High Cabinet and Low Cabinet are both storage units and bookcases, and alternate open compartments with shelves and compartments with doors. Perfect against the wall or in the centre of the room, they can also be used to define, divide and organise spaces. The two versions differ in terms of the arrangement of the elements and vertical dividers which, in the wall variant, are all further back, making it possible to optimise the spaces.

## コンセプト

「Jobs Bookcase」は、ロドルフォ・ドルドーニによる新技術に伴う進化に対する仔細な研究と、レザー、艶やかな木材、艶消しされた木材、サテン仕上げスチールの構造といったシンプルかつナチュラルなトーンの、ボリュームの異なる様々な素材の厳選から誕生した書棚です。収納ケースと本棚が合体した書棚「Jobs Bookcase」ではオープンコンパートメント、棚、扉付きコンパートメントが交互に並んでいます。壁際用または部屋中央に置くタイプがあり、スペースを区分・整理するための仕切りとして使用することも出来ます。書棚のバージョンによって各エレメントや縦仕切りの配置が異なっており、壁用バージョンでは全てがより後退した位置にあります。スペースを最適に活用出来るようになっています。

## 理念

Jobs Bookcase系列源自Rodolfo Dordoni对新科技相关行为发展的专注研究，以及材料的精心筛选：软皮、抛光和哑光木材钢质轧光结构，以稳重精简的色调装饰不同轮廓，并定义全新工作区域。Jobs Bookcase低柜和高柜既是收纳柜，也是书柜，外露隔槽、架板和带门板的隔槽组合而成。既可以沿墙壁摆放，也可以置于房间中央，还可以用于界定、划分、组织空间。依据垂直元素和隔断的布置，分为两种类型，在沿墙壁摆放的版本中，均更加靠后，有助于优化空间。



Le librerie Jobs Bookcase hanno mensole in rovere Piombo o Tabacco opaco con spessore importante. Gli elementi divisori a "T", composti da un pannello verticale in legno laccato lucido e pannello di fondo in Pelle Frau®, sono disposti sulle mensole con schema irregolare. I montanti verticali con la caratteristica sezione a "T", elementi identificativi della collezione, sono in acciaio satinato verniciato piombo, fissati alle estremità della libreria. Il tutto in un'alternanza equilibrata di pieni e vuoti. Gli elementi verticali dei divisori sono in legno multistrato di betulla impiallacciato rovere Piombo o rovere Tabacco con finitura lucida, disposti perpendicolarmente alla lunghezza dei ripiani. I pannelli in MDF con rivestimento in Pelle Frau® sono disposti parallelamente alla lunghezza dei ripiani.

Lead-coloured steel for the vertical uprights, with the characteristic T-section common to all Jobs elements. Pelle Frau® leather for the upholstery of the MDF doors. The same material for all of the other elements, shelves, compartments and rear panel: the oak veneer with lead or tobacco stain elegantly alternates glossy and matt surfaces. The structure of the Jobs Low Cabinets is in MDF panels with lead or tobacco oak veneer with glossy finish, with the exception of the top refined with matt finish. The base is in lead-coloured brushed steel with adjustable feet and central connecting crossbar painted in scratchproof texturised black paint. The back of the Jobs Bookcase High Cabinet and Low Cabinet has a tilting door that accesses a little internal compartment which allows cables, which rise from the floor to the top, to pass through the slot that runs along the entire length of the surface.

書棚「Jobs Bookcase」にはリードカラーまたはマットタバコカラーのオーク材の分厚い棚板が備わっています。光沢ラッカー仕上げの木材の垂直パネルとPelle Frau®製バックパネルで形成された「T」字型の仕切りが棚上に不規則に配置されています。コレクションの特徴である断面がT字型の垂直支柱はリードカラー塗装されたサテン仕上げスチール製で、書棚の両端に固定されています。空間の満空がバランスよく交錯しています。仕切りの垂直エレメントは光沢仕上げのリードカラーオーク材またはタバコカラーオーク材で化粧張りされたカバの積層板で作られており、棚板に対して垂直に配置されています。Pelle Frau®でコーティングされたMDF製パネルは棚板に対して平行に配置されています。

垂直支柱使用汞色钢材，采用特色T型截面，是Jobs各款家具的特色所在。中密度纤维板小门板覆盖Pelle Frau®软皮。所有其他元素、架板、隔槽和背板也使用相同的材料：汞色或烟草色橡木贴面与典雅的抛光和哑光表面交替。Jobs低柜结构采用中密度木质纤维板，镶贴汞色或烟草色抛光表面处理橡木，顶板则使用哑光表面处理。底座使用汞色喷漆轧光钢，搭配可调节底脚和中心连接横撑，黑色喷漆，采用防划表面处理。Jobs Bookcase高柜和低柜后侧配有可翻转门板，门后是一个内部小隔槽，用于接出缆线，通过沿整个表面横向排列的沟槽从地板处一直延伸到顶板。



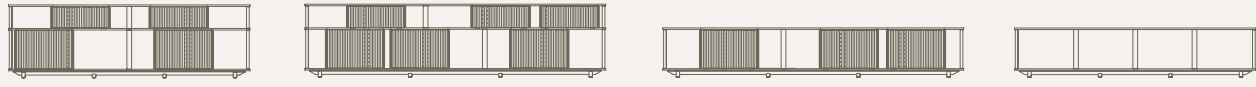

#### CONCEPT

Con i contenitori e librerie Lloyd, Jean-Marie Massaud progetta un intero sistema a geometria variabile, che offre una gamma vastissima di soluzioni diverse per forma, assetto e dimensione. Sottili bacchette di legno verticali formano griglie leggere, che scorrono per tutta la lunghezza su invisibili binari orizzontali. Ogni griglia è spostabile a piacere per creare sequenze sempre diverse. Una partitura cangiante di pieni e vuoti, di luci e ombre. Un gioco sensuale che lascia intravedere il contenuto, libri e oggetti, senza svelarlo del tutto. La tecnologia più evoluta incontra i materiali della tradizione, legno e cuoio, per dare vita a una struttura solida e essenziale.

Gli elementi orizzontali su cui scorrono le griglie sono in stratificato HPL, materiale che anche in spessori molto sottili garantisce stabilità e resistenza, placcato con piallaccio naturale di rovere nella finitura piombo opaco. I montanti verticali in cuoio, sono disposti a distanza regolare l'uno dall'altro, per dare ritmo e esaltare il libero gioco delle griglie. Ogni singola griglia è un minuzioso lavoro di ebanisteria. In massello di rovere, si muove lungo binari intagliati nei ripiani ed è dotata di "pattini" in materiale plastico per diminuire l'attrito. Le bacchette, in massello di rovere, sono intagliate in

#### CONCEPT

With the Lloyd storage units and bookcases Jean-Marie Massaud designs a system of variable geometries. Thin vertical wooden rods create light grilles that run from top to bottom on invisible horizontal rails. Each grille can be moved as desired to create sequences that are different each time. A fluctuating score of solids and voids, of light and shade. A sensual game that offers a glimpse of the contents, books and objects without fully revealing them. The most advanced technology is combined with traditional materials, wood and saddle leather, to form a solid and minimalist structure.

The horizontal elements on which the grilles slide are made from HPL laminate, a material which even in very thin layers guarantees stability and strength, with a natural oak veneer in a matt lead finish. The vertical saddle-leather uprights are placed at regular intervals to give the piece of furniture rhythm and enhance the liberal effect of the grilles. Each individual grille is a painstaking piece of cabinetwork. Made of solid oak, they move along rails carved into the shelves and are furnished with plastic runners to reduce friction. The solid oak rods are cut in different thicknesses and then individually glued by hand. The sides of the structure are closed by fixed solid oak grilles. The Lloyd storage units

#### コンセプト

ジャン・マリー・マッソーが考案した完全な可変式収納/書棚システム「Lloyd」は、形状、整理、サイズの異なる非常に幅広いソリューションを提案します。木製の細い垂直の棒が、棚全体を横断する水平のインビジブルレールに沿ってスクロールする軽快な格子を形成しています。どの格子も好きなように動かせるので、常に変化に富んだシークエンスをお楽しみ頂けます。開いた空間と閉じた空間、光と影が交錯し、変化します。中の本や物を完全に公開せずに垣間見せる官能的な視覚効果を演出します。より進化した技術と、木材やなめし革といった伝統的な素材が融合し、重厚でクリーンな構造に命を吹き込みます。

格子をスクロールさせる水平エレメントには非常に薄く、同時に安定性と耐久性を保證するHPLという素材が使用されており、マットリード仕上げオーク材のベニヤ単板で化粧張りされています。一定間隔で配置されたなめし革の垂直支柱が、格子の自由なレイアウトを際立たせ、リズムを与えます。各格子は家具職人の精密な作業によって一つ一つ丁寧に制作されています。オーク心材を使用した書棚では、格子は棚板に埋め込まれたレールに沿って移動し、摩擦を低減するためにプラスチック素材の「スキッド」が備わっています。オーク心材の棒は様々な厚さに切り抜かれ、一つずつ手作業で接着されています。書棚の両端にはオーク心材の

#### 理念

Jean-Marie Massaud为Lloyd收纳柜和书柜设计了一套灵活的几何系统。纤细的垂直木片构成轻盈的格栅，可以沿隐形水平轨道全长滑动。每个格栅可根据喜好移动，构成多变的序列。虚与实、明与暗相互结合勾勒出的多变图谱。透过这样的感性组合，可以瞥见放在柜子中的书籍和物品，但不会展现全部。最先进的技术与木材和皮革传统材料相结合，带来坚实而简约的结构。

格栅在层压HPL倍耐板水平元素上滑动，尽管这种材料极薄，依然能够保持稳定性和坚固性，其上还贴有哑光汞表面处理天然橡木片。皮革垂直支柱互相之间距离规则，带来节奏感，彰显自由的格栅组合。每一个格栅都是一件小巧的木工作品。以橡木实木为材质，沿隔层内刻轨道移动，配有塑料“滑座”，减少摩擦。橡木实木片切割厚度各不相同，之后手工逐一粘合。置物架侧面以固定式橡木实木格栅封闭。Lloyd收纳柜和书柜分为两款：沿墙壁摆放或置于房间中央。后一版本两侧（前侧和后侧）均具有滑动格栅。沿墙壁摆放的版本则仅在前侧配有滑动格栅，与墙壁接触的后侧使用哑光黑色喷漆中密度纤维板封闭，内表面（底板）可以覆盖皮革。Lloyd书柜和收纳柜支脚使用钢材制成。外侧和前侧支脚使用哑光枪管色喷漆，中央支脚略微靠后，采用哑光黑色漆绘。



spessori diversi e poi incollate a mano una a una. I fianchi del mobile sono chiusi da griglie fisse realizzate in massello di rovere. I contenitori e librerie Lloyd sono disponibili in due varianti: da parete o centro stanza. Quest'ultima presenta griglie scorrevoli su entrambi i lati (frontale e posteriore). La versione da parete ha invece griglie scorrevoli solo sul lato frontale mentre il lato posteriore, a contatto con il muro, è chiuso da un pannello in MDF verniciato nero opaco che, sul lato interno (fondo) può essere rivestito in cuoio. Le librerie e contenitori Lloyd hanno i piedi realizzati in acciaio. Quelli esterni e in primo piano sono verniciati canna di fucile opaco mentre quelli centrali, più arretrati, sono laccati nero opaco.

and bookcases are available in two variants: a wall version and a freestanding version. The latter has sliding grilles on both sides (front and rear). The wall version has sliding grilles on the front only while the back, in contact with the wall, is closed by a matt black lacquered MDF panel which, on the inside, can be upholstered in saddle-leather. The Lloyd bookcases and storage units have steel feet. The exterior feet at the front have a gunmetal grey finish while the central feet, set further back, have a matt black lacquer.

格子が固定されています。収納/書棚システム「Lloyd」には壁際に置くタイプと部屋の中央に置くタイプの2つのバージョンがあります。部屋の中央に置くタイプの書棚ではスクロール式格子が両面（前面と後面）に付いています。壁際に置くバージョンではスクロール式格子は前面だけで、壁と接する後面はマットブラックカラー塗装されたMDFパネルで閉じられています。両サイド内側（及び奥）はなめし革でコーティングすることも可能です。外側及び前側の脚はマットガンメタルカラー塗装されています。中央及び後ろ側の脚はマットブラックラッカー仕上げです。

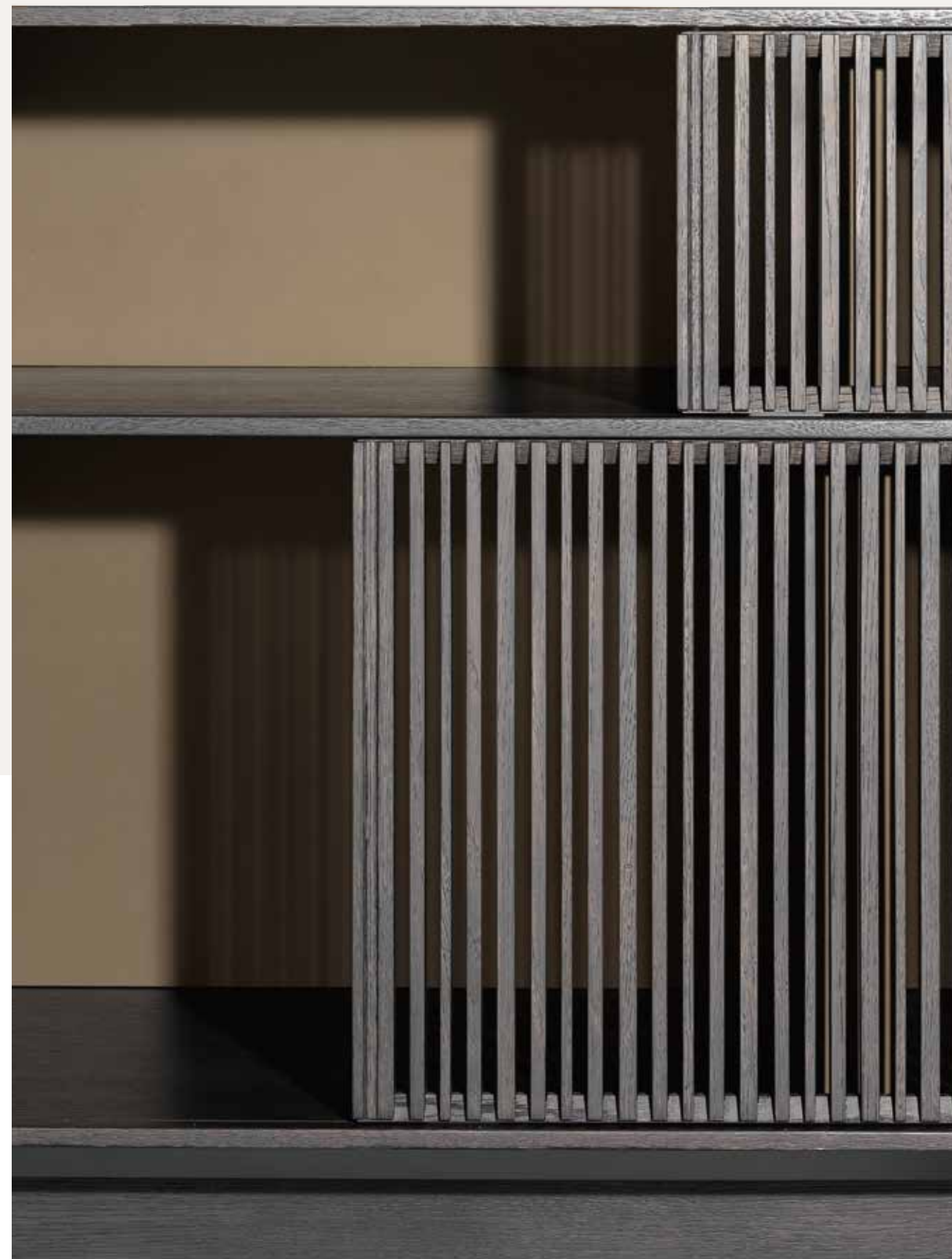



## Ren

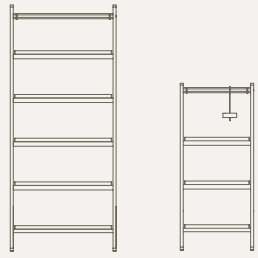

## CONCEPT

La libreria Ren arricchisce la collezione omonima disegnata da Neri & Hu. Fil rouge continua ad essere il segno ispirato all'ideogramma cinese "ren", che significa "persona", "essere umano". È un intrecciarsi grafico di linee che comunica un'intima eleganza. Sono piccole, leggere architetture, fatte di geniali sospensioni, giochi di contrappesi, semplici incastri che richiamano una concezione orientale degli spazi e del design, e vengono realizzati con materiali preziosi e tecniche artigianali che appartengono indissolubilmente alla tradizione di Poltrona Frau.

Nella libreria Ren i due montanti laterali, leggermente inclinati, sorreggono i piani degli scaffali in multistrato di betulla impiallacciati sui fianchi in noce Canaletto e rivestiti in cuoio Saddle Extra. La traversa superiore si fissa al muro tramite ganci di ancoraggio in metallo con finitura ottone naturale. La libreria viene proposta nella versione bassa, con vaschetta tonda portaoggetti rivestita in cuoio sospesa alla traversa superiore, e nella versione alta. Si differenziano per l'altezza, la larghezza e il numero di ripiani. Entrambe le varianti possono essere completate dai fermalibri in acciaio spazzolato con finitura ottone naturale.

## CONCEPT

The Ren bookcase enriches the collection of the same name designed by Neri & Hu. The underlying theme continues to be the Chinese "ren" symbol. A graphical weave of lines that exudes intimate elegance. Small, light architectures made up of ingenious suspensions, clever balances, simple interconnections inspired by an oriental concept of spaces and design. And they are produced using fine materials and artisan techniques inextricably linked with the Poltrona Frau tradition.

The Ren bookcase is a graphical weave of lines. The two lateral uprights, slightly inclined, support the birch plywood shelves, upholstered in saddle-leather with a Canaletto walnut veneer on the sides. The upper crosspiece is fixed to the wall using metal hooks with a natural brass finish. The bookcase comes in a low version with a round multi-purpose tray upholstered in saddle-leather hanging from the upper crosspiece, and in a tall version. They differ from each other in terms of height, width and number of shelves. Both variants can be completed with bookends in brushed steel with a natural brass finish.

## コンセプト

書棚「Ren」がネリ&フーによってデザインされた同名のコレクションに新たに追加されました。コレクションの他の製品と同様、「人間」や「人類」を意味する中国の漢字「Ren」(人)に着想を得た輪郭がテーマになっています。線が交差するデザインが、親密なエ

レガンスを伝えています。独創的なサスペンションシステム、絶妙なバランス、東洋における空間とデザインのコンセプトを彷彿させるシンプルな結合部から成る軽快でコンパクトな構造が、Poltrona Frauの伝統の代名詞である高級素材と卓越したクラフトマンシップを駆使して実現されました。

書棚「Ren」のやや傾斜した両側の支柱が化粧張りされたカバ積層板の棚板を支えています。棚板の両端は黒クルミ製でなめし革Saddle Extraでコーティングされています。ナチュラルプラス仕上げの金属製固定フックを使って上部の横木を壁に固定します。書棚には背が低いバージョンと高いバージョンがあります。低いバージョンでは小物用のなめし革張り円形トレーが横木から吊り下げられています。2つのバージョンでは高さ、幅、棚板数が異なります。どちらのバージョンでもナチュラルプラス仕上げブラッシュスチール製のブックエンドを追加することが出来ます。

## 理念

Ren书柜为Neri & Hu设计的同名系列增添新成员。以中文“人”字为灵感源泉的符号依然是贯穿本设计的红线。图形线条交织，传达最深层次的典雅。小巧轻盈的结构，以绝妙的悬挂系统、配重组合、简单的嵌套构成，呼应东方特色的空间设计理念，并使用与Poltrona Frau传统不可分割的珍贵材料和手工技艺。

Ren书柜是图形线条的交织。两个侧支柱略微倾斜，支撑桦木胶合板支撑的书架表面，覆盖皮革，侧面镶贴黑核桃木。上横撑通过采用天然黄铜表面处理金属挂钩固定在墙上。矮版书柜配有圆形置物篮，覆盖皮革，悬挂在上横撑上，高版中也采用了这种配置。区别在于高度、宽度和隔层数。两个版本都配有镀有天然黄铜表面处理的拉丝钢质书挡。



# Category Index

366 — Chairs and Small Armchairs

369 — Tables and Desks

371 — Bookcases and Storage Units

**Please note:**

this catalogue shows only some technical drawings, in order to know all the availabilities please refer to the current price list.

**Archibald** — Armchair with leather upholstery

5506101

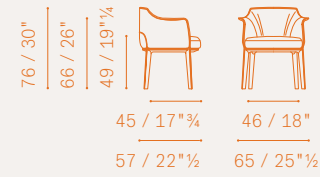

**Archibald** — Armchair with fabric upholstery

5506101

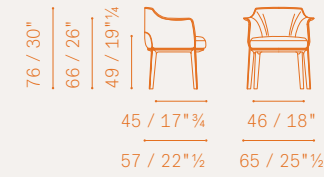

**Archibald** — Swivel amchair with leather upholstery

5506101

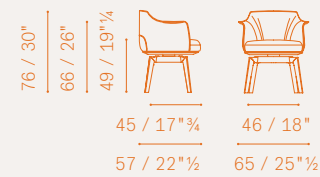

**Archibald** — Swivel amchair with fabric upholstery

5506101

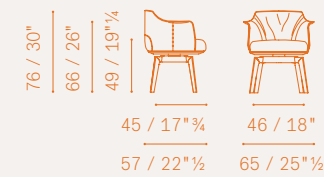

**Donald** — Chair with writing table

5272001



**Ginger** — Chair Full upholstery shell Fixed

5542101

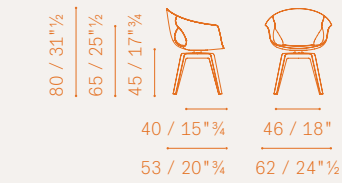

**Ginger** — Chair Full upholstery shell Swivel

5542101

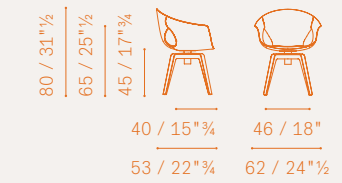

**Ginger Ale** — Armchair wood legs base / Totally upholstered shell fixed chair

5542017

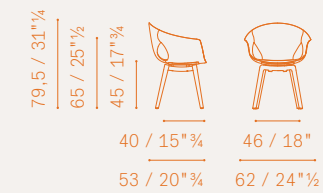

**Ginger Ale** — Armchair 4-legs base / External varnished shell fixed chair

5542017

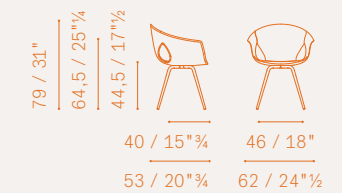

**Ginger Ale** — Armchair 4-legs base / Totally upholstered shell fixed chair

5542017

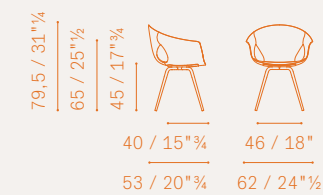

**Ginger Ale** — Full upholstery shell Fixed chair swivel chair

5542101

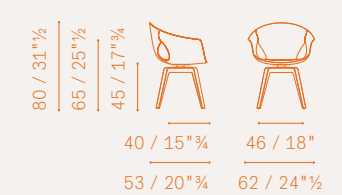

**Ginger** — Chair Saddle Extra external shell Fixed

5542101

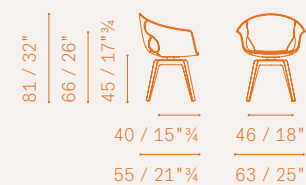

**Ginger** — Chair Saddle Extra external shell Swivel

5542101

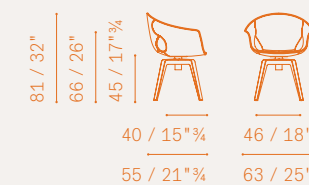

**Ginger Ale** — Full upholstery shell swivel chair

5542101

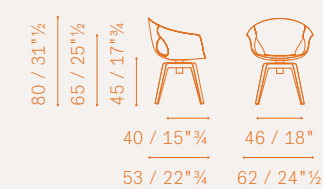

**Ginger Ale** — Armchair 4-spokes base / External varnished shell fixed chair

5542018

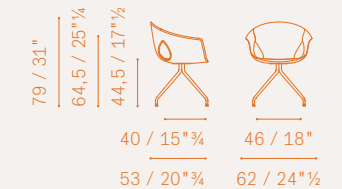

**Ginger Ale** — Armchair 4-spokes base / Totally upholstered shell

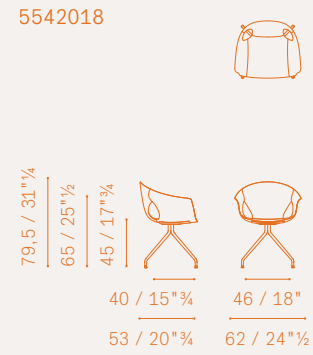

**Ginger Ale** — Armchair column base / External varnished shell

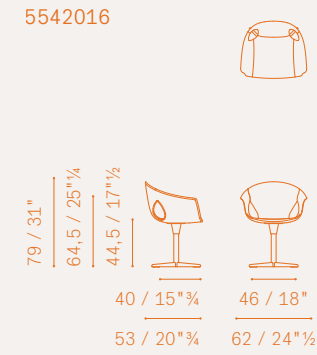

**Ginger Ale** — Armchair column base / Totally upholstered shell

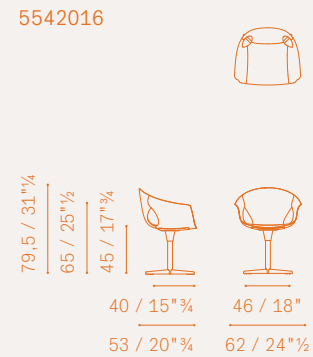

**Ginger Ale** — Armchair 5-spokes base with castors / External varnished shell

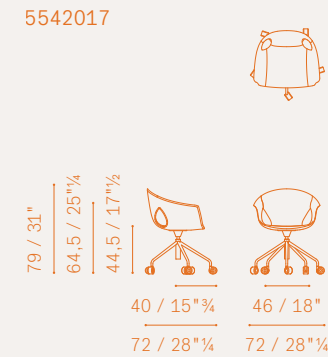

**Ginger Ale** — Armchair 5-spokes base with castors / Totally upholstered shell

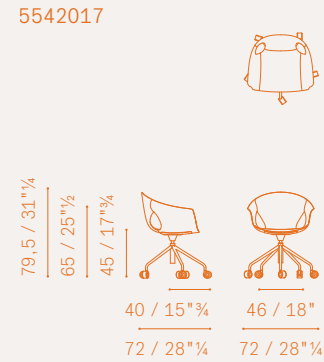

**Ginger Ale** — Armchair 5-spokes base with castors and adjustable height / External varnished shell

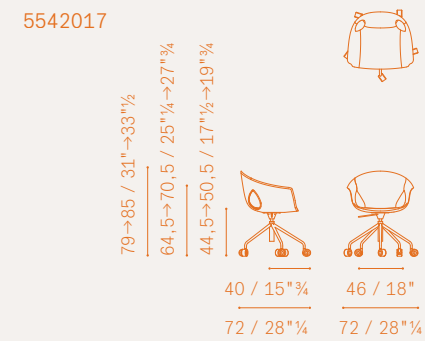

**Ginger Ale** — Armchair 5-spokes base with castors and adjustable height / Totally upholstered shell



**Fred** — Home Desk

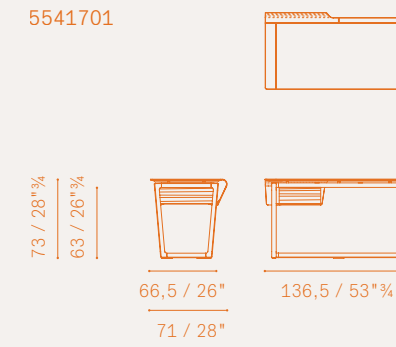

**Iren** — Home-desk | Freestanding

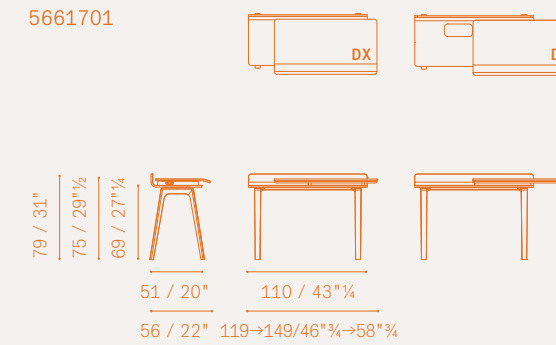

**Iren** — Home-desk | Wall

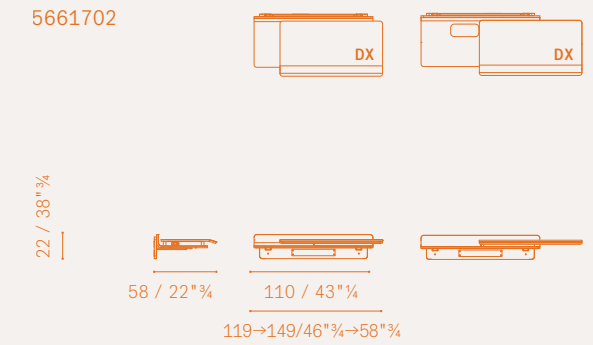

**Mesa Due** — Table Ø 120

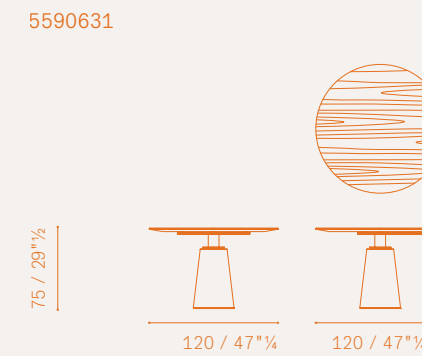

**Mesa Due** — Table Ø 120

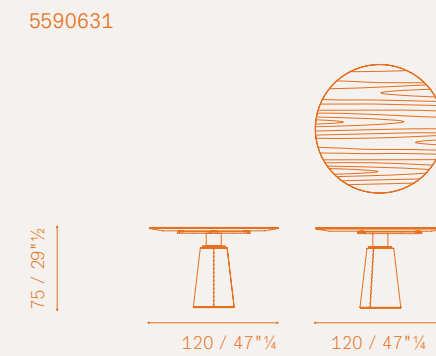

**Mesa Due** — Table Ø 120

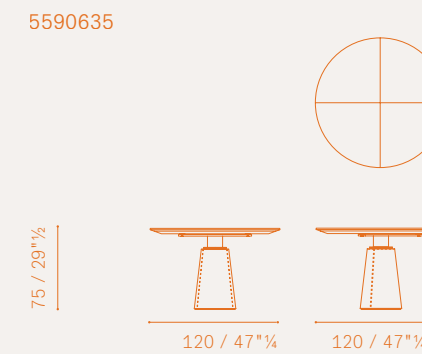

**Mesa Due** — Table Ø 150

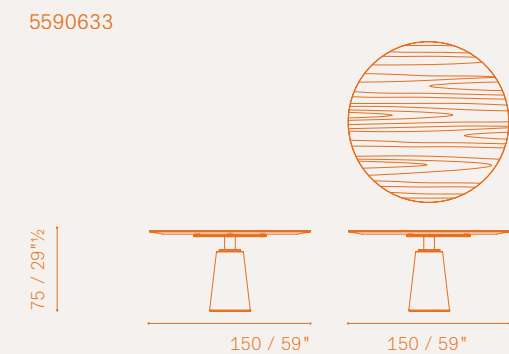



**Mesa Due** — Table Ø 150

5590633

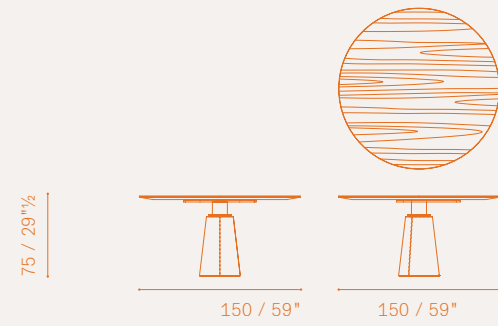

**Mesa Due** — Table Ø 150

5590637

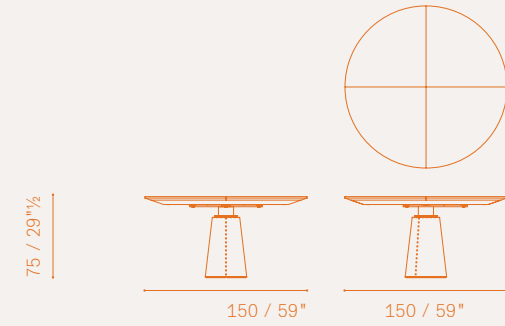

**Mesa Due** — Table Ø 150 cm

5590633

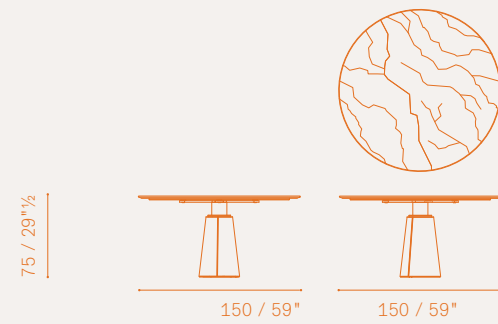

**Mesa Due** — Table Ø 180 cm

5590637

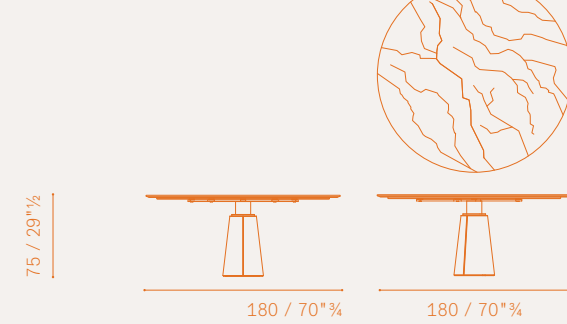

**Mesa Due** — Table 260 × 110 cm

5590637

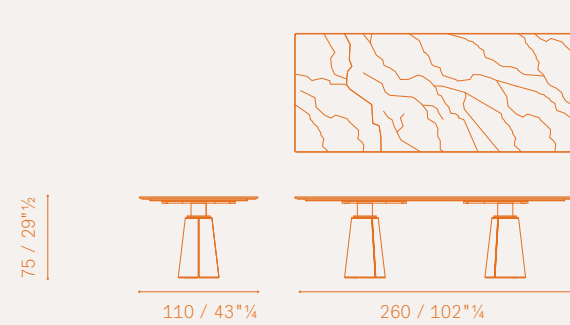

**Peek-a-Book** — Desk

5663701

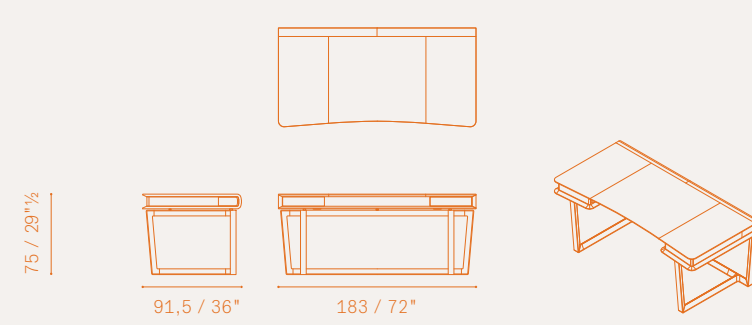

**Segreto** — Home-desk

5658613

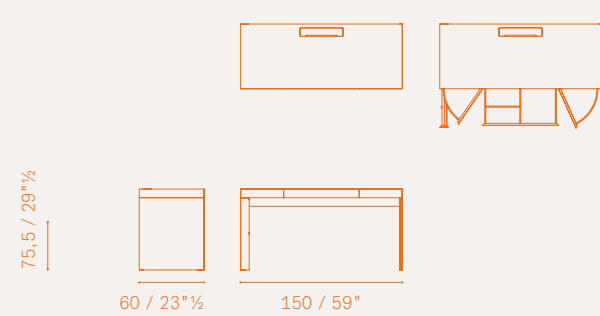

**Jobs Bookcase** — Bookcase 177x182 Freestanding

5580786

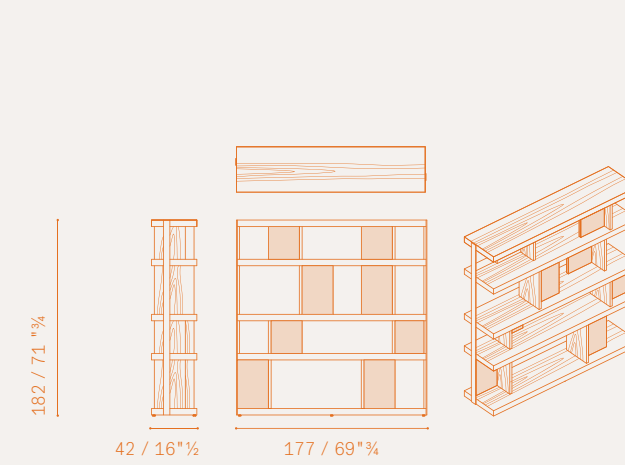

**Jobs Bookcase** — Bookcase 177x182 Wall

5580796

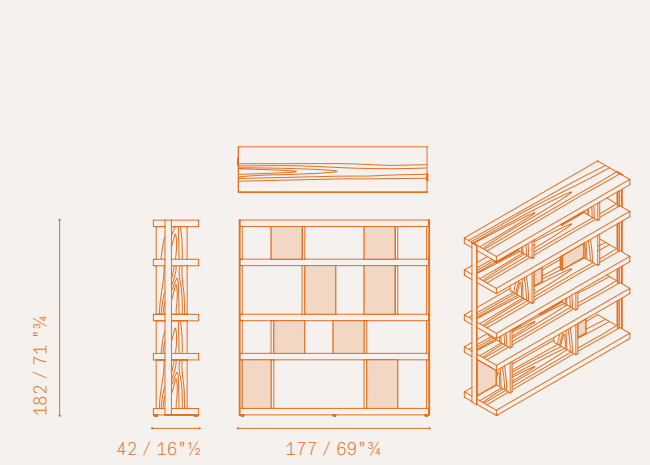

**Jobs Bookcase** — Bookcase 234x145 Freestanding

5580787

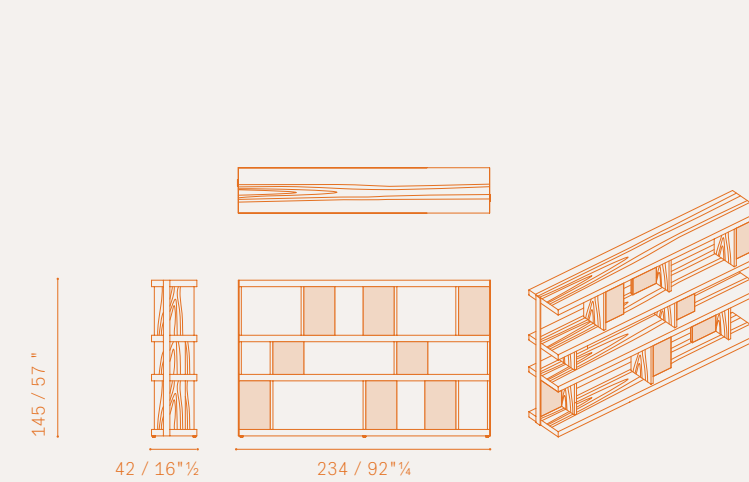

**Jobs Bookcase** — Bookcase 234x145 Wall

5580797

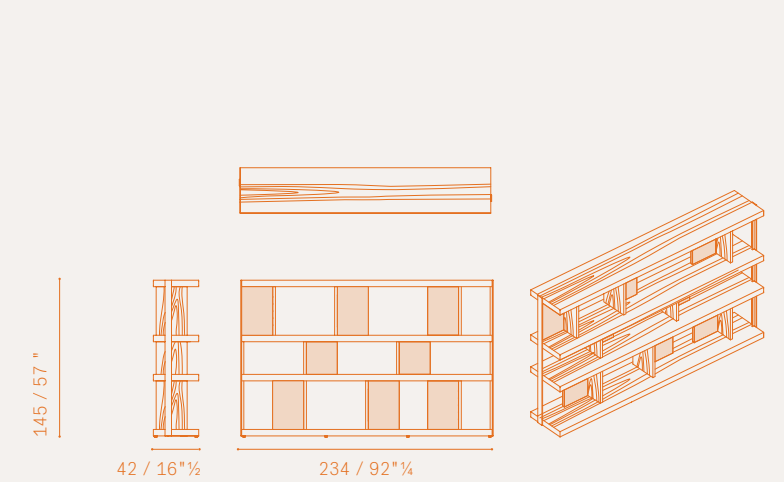

**Lloyd** — Low Cabinet 225x46 Freestanding

5607780

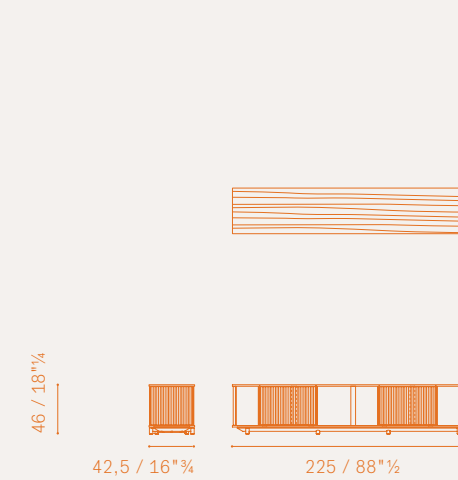

**Lloyd** — Low Cabinet 225x46 Wall

5607790

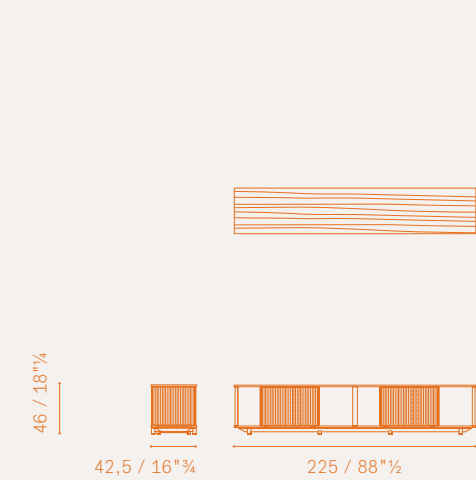

Lloyd — Low Cabinet 225x68 Freestanding

5607781

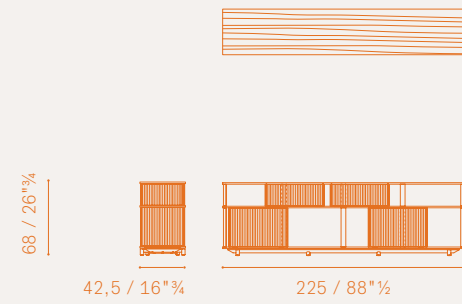

Lloyd — Low Cabinet 225x68 Wall

5607791

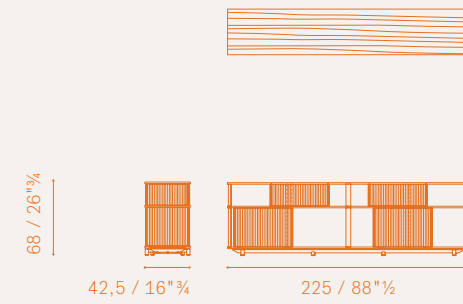

Lloyd — Bookcase 225x166 Freestanding

5607785

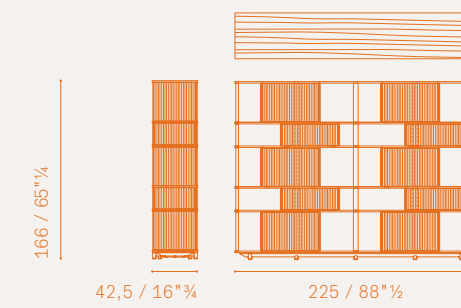

Lloyd — Bookcase 225x166 Wall

5607795

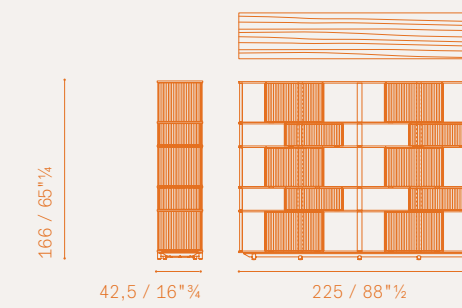

Lloyd — Low Cabinet 280x46 Freestanding

5607782

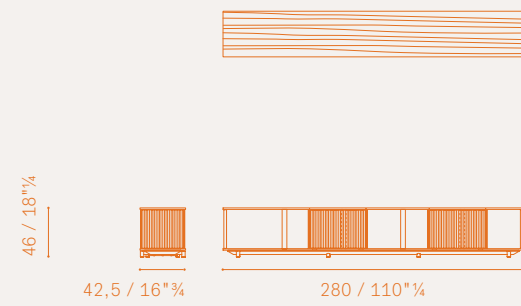

Lloyd — Low Cabinet 280x46 Wall

5607792

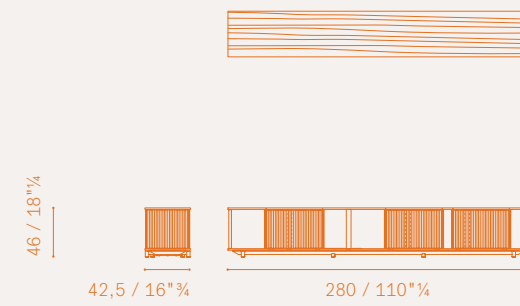

Lloyd — Bookcase 225x188 Freestanding

5607786

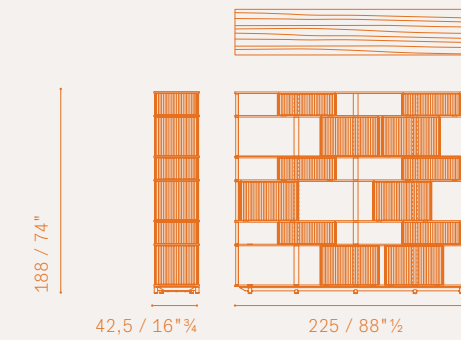

Lloyd — Bookcase 225x188 Wall

5607796

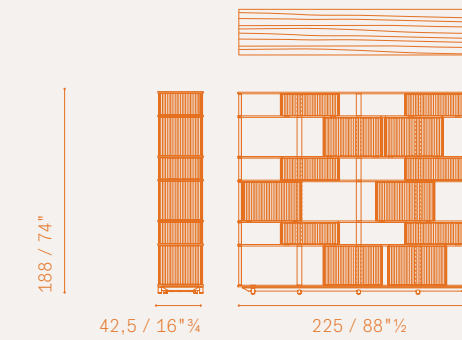

Lloyd — Low Cabinet 280x68 Freestanding

5607783

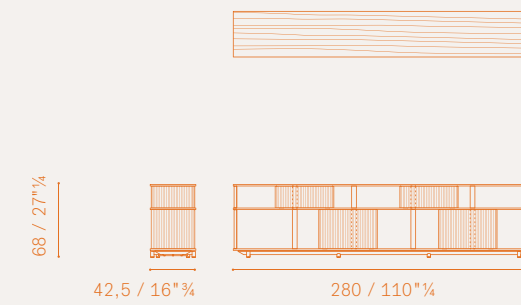

Lloyd — Low Cabinet 280x68 Wall

5607793

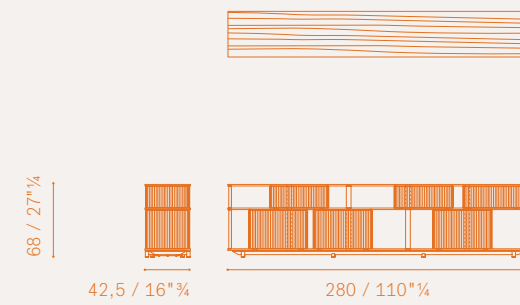

Lloyd — Bookcase 280x166 Freestanding

5607787

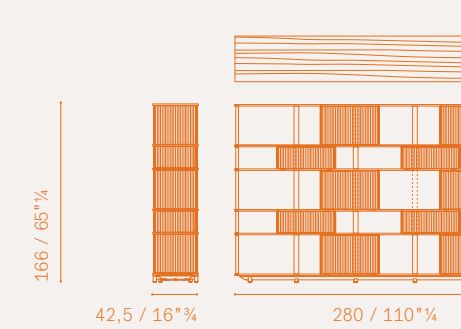

Lloyd — Bookcase 280x166 Wall

5607797

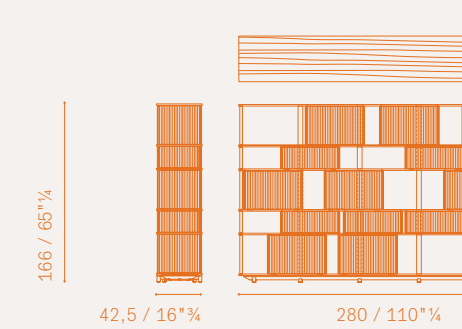

# Bookcases, Storage Units

Lloyd — Bookcase 280x188 Freestanding

5607788

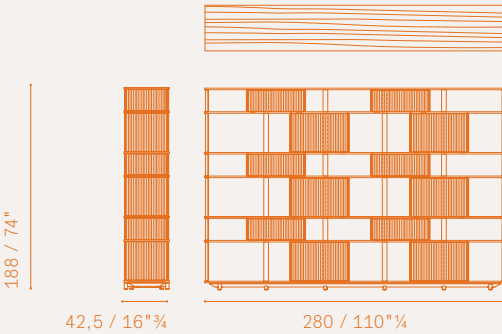

Lloyd — Bookcase 280x188 Wall

5607798

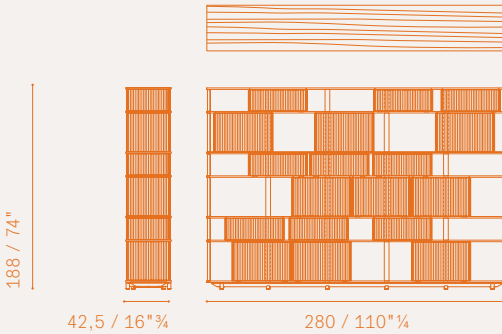

Ren — Low Bookcase

5608785

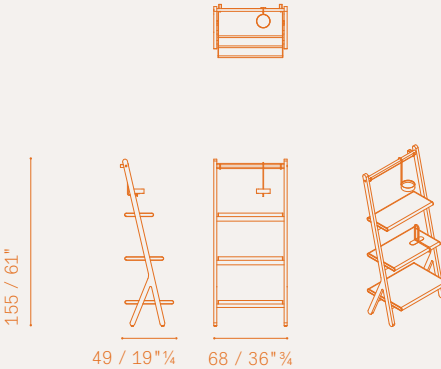

Ren — High Bookcase

5608786

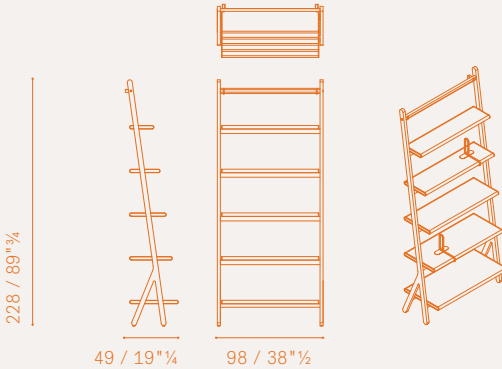

Ren — Book ends

5608130

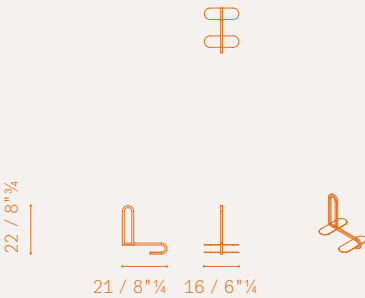



# Materials and Colours

379 — Pelle Frau®

390 — Fabrics

399 — Woods / Marbles / Stones / Fenix© /  
Ginger Ale shell

**Please note:**

This digital samples book is for reference only. Colours are to be considered purely indicative, slight differences in coloration and finish may occur.

# Pelle Frau®

## COLORSPHERE®

**380** SC 0 Polare  
→ SC 01 Avorio  
SC 04 Latte  
SC 05 Stucco  
SC 06 Calicot  
SC 10 Antracite  
SC 19 Georgette  
SC 20 Inchiostro  
SC 21 Amianto  
SC 22 Chiffon  
SC 23 Tortora  
SC 26 Topo  
SC 28 Seppia  
SC 29 Ardesia  
SC 31 Quarzo Fumè  
SC 32 Caolino  
SC 33 Travertino  
SC 34 Maggese  
SC 40 Cachemire  
SC 42 Maquillage  
SC 44 Noisette  
SC 46 Biscuit  
SC 48 Tonka  
SC 51 Panna  
SC 52 Daino  
SC 53 Creta  
SC 55 Camel Hair  
SC 56 Siena  
SC 57 Torba  
SC 59 Noce di Pecan  
SC 65 Vachette  
SC 66 India  
SC 67 Chiodi di Garofano  
SC 68 Sahara  
SC 69 Iroko  
SC 74 Nocciola  
SC 80 Bruno Havana  
SC 92 Garnet  
SC 93 Brossura  
SC 96 Mattone  
SC 99 Carrubo

SC 100 Fondant  
SC 120 Calypso  
SC 127 Siam  
SC 128 Carminio  
SC 132 Eggshell  
SC 133 Paglierino  
SC 136 Ginger Bread  
SC 140 Mimosa  
SC 146 Coccio Pesto  
SC 148 Lacca  
SC 173 Glauco  
SC 175 Bengali Green  
SC 176 Darsena  
SC 177 Limo  
SC 178 Alpi  
SC 179 Brughiera  
SC 180 Celadon  
SC 187 Selva  
SC 188 Viridiana  
SC 209 Cypress  
SC 233 Bardiglio  
SC 248 Iris  
SC 250 Vermillon  
SC 254 Steel Blue  
SC 255 Belladonna  
SC 256 Ume  
SC 258 Mist  
SC 274 Fresco Blue  
SC 276 Mineral Blue  
SC 278 Atlantic Blue  
SC 279 Alchemy  
SC 280 Abyss

## HERITAGE

**385** Bordeaux  
→ Castagno  
Ghianda  
Mahagoni  
Nero  
Testa di moro

## NEST

**386** Ambra  
→ Ammonite  
Arenaria  
Argilla  
Azul  
Calcedonio  
Cemento  
Eliodoro  
Grafite  
Granato  
Larimar  
Luna  
Madreperla  
Malachite  
Marte  
Pomice  
Salgemma  
Silice  
Terra di Cassel  
Tufo

## SOUL

**387** Amy  
→ Anita  
Diana  
Dusty  
Joe  
Nina  
Otis  
Ray  
Smokey  
Stevie  
Whitney  
Wilson

## SADDLE

**388** Avocado  
→ Avorio  
Blue  
Caffè  
Cognac  
Naturale  
Nero corvino  
Neve  
Oliva  
Polare  
Rosso bulgaro  
Rosso conero  
Rosso Frau  
Sabbia  
Tortora

## SADDLE EXTRA

**389** Carbone  
→ Cammello  
Corda  
Polvere  
Talpa  
Testa di moro

## SADDLE EXECUTIVE

**389** Bourbon  
→ Ink  
Havana

INTO THE BLACK

05 Stucco



20 Inchiostro



21 Amianto



26 Topo



28 Seppia



31 Quarzo Fumè



34 Maggese



40 Cachemire



MILKY WAY

MILKY WAY FROZEN WHITES

06 Calicot



19 Georgette



0 Polare



04 Latte



22 Chiffon



23 Tortora



32 Caolino



33 Travertino



51 Panna



FOUNDATION

42 Maquillage



44 Noisette



46 Biscuit



TIERRAS

TIERRAS BLONDE WOODS

52 Daino



53 Creta



55 Camel Hair



56 Siena



TIERRAS TANNERY

65 Vaquette



66 India



67 Chiodi di Garofano



68 Sahara



69 Iroko



TIERRAS EVER BROWNS

29 Ardesia



57 Torba



59 Noce di Pecan



80 Bruno Havana



100 Fondant



RED MEMORIES

92 Garnet

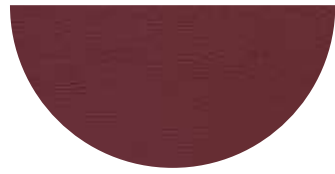

93 Brossura



99 Carrubo



127 Siam



128 Carminio



146 Coccio Pesto



148 Lacca



WINTER GARDEN

WINTER GARDEN TENDER IS THE NIGHT

10 Antracite



178 Alpi



173 Glauco



176 Darsena



187 Selva



209 Cypress



177 Limo



179 Brughiera



280 Abyss



180 Celadon



WINTER GARDEN OUT OF THE BLUE

233 Bardiglio



254 Steel Blue



274 Fresco Blue



276 Mineral Blue

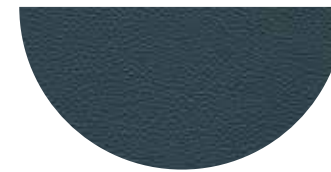

278 Atlantic Blue





BACK IN TOWN

BACK IN TOWN GION

140 Mimosa



255 Belladonna



256 Ume



258 Mist



279 Alchemy

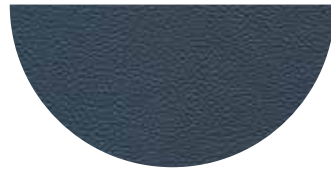

BACK IN TOWN IPANEMA

01 Avorio



48 Tonka



74 Nocciola

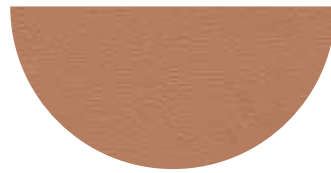

120 Calypso



136 Ginger Bread



175 Bengali Green



BACK IN TOWN FAUBOURG

96 Mattone

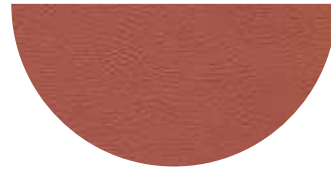

132 Eggshell



133 Paglierino



188 Viridiana



248 Iris



250 Vermillon



Pelle Frau® Heritage

Bordeaux

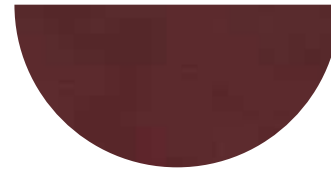

Castagno



Ghianda



Mahagoni



Nero

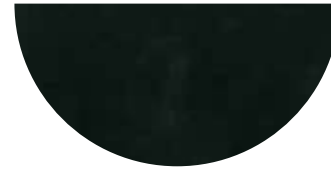

Testa di moro



Pelle Frau® Nest

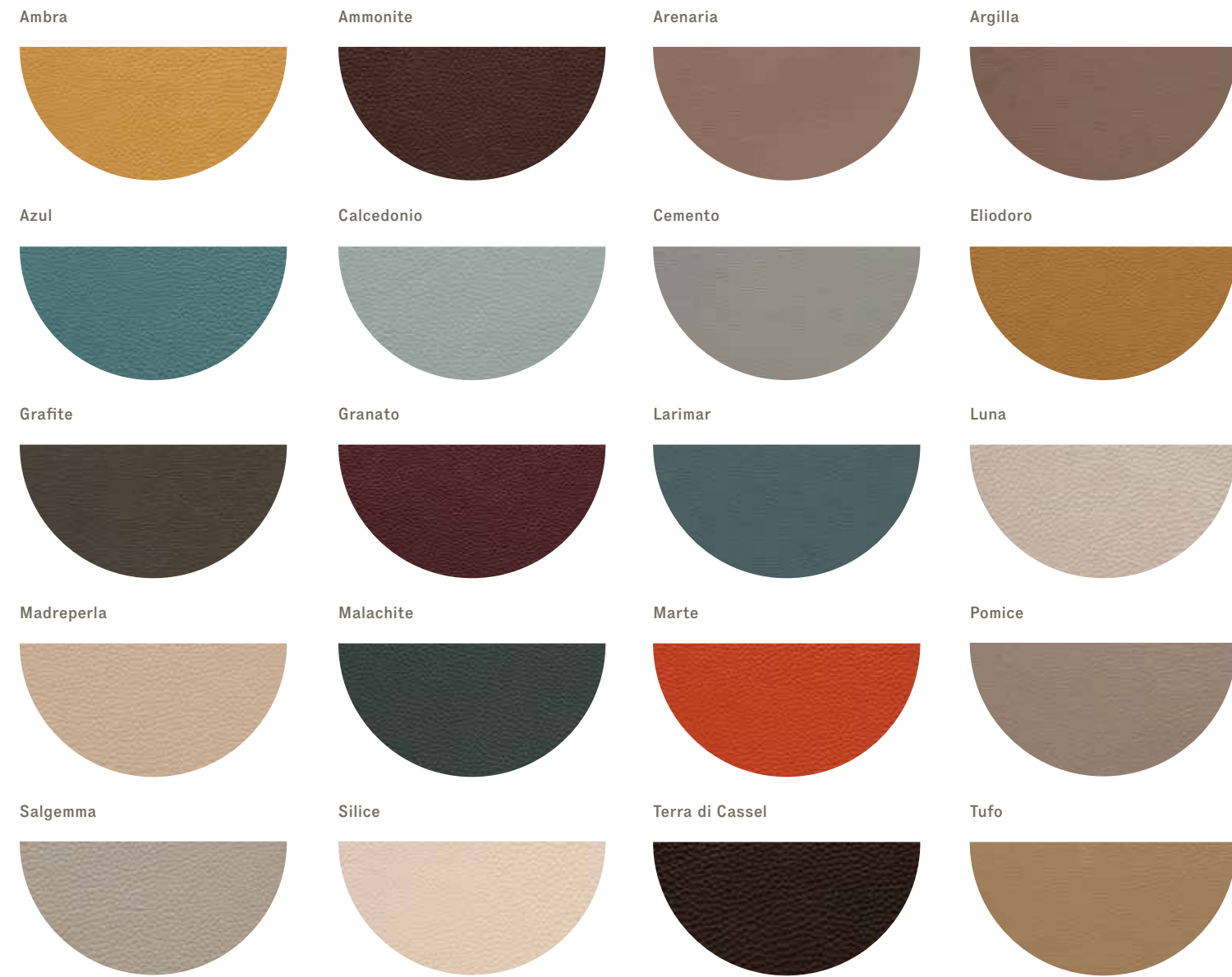

Pelle Frau® Soul

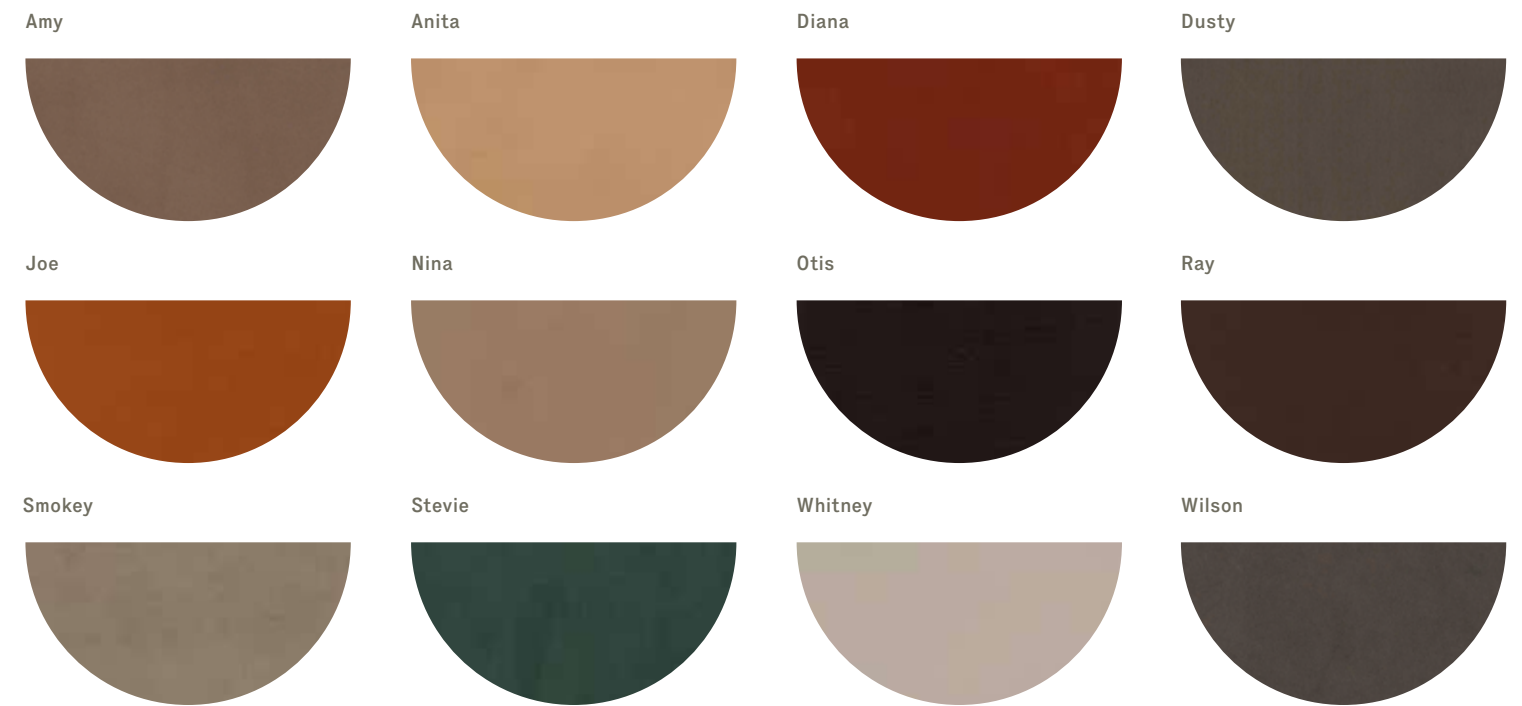

# Pelle Frau® Saddle

Avocado



Avorio



Blue



Caffè



Cognac



Naturale



Nero Corvino



Neve



Oliva



Polare



Rosso bulgare



Rosso conero



Rosso Frau



Sabbia



Tortora



# Pelle Frau® Saddle Extra

389

Carbone



Camello

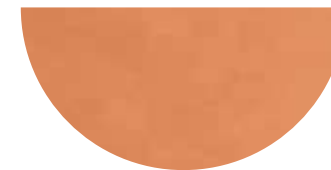

Corda



Polvere



Talpa



Testa di moro



# Pelle Frau® Saddle Executive

Bourbon



Ink



Havana



	<b>BARKLEY (VELLUTO/VELVET)</b>	<b>GUATEMALA</b>	<b>NOUVEAU</b>	<b>TWILL</b>
391 →	003 Perla 027 Lichene 029 Topo 30 Testa di moro 37 Avio	394 →	Bianco Ecrù Grigio Castoro Sughero Piombo Lavagna	395 →
	<b>BOUCLÈ</b>		<b>PALTÒ</b>	397 →
391 →	101 102 103 104 105	<b>HERMOSO</b>	395 →	004 Cotto 006 Acqua 018 Grigio 102 Ruggine 109 Cenere 114 Beige
	<b>DAMIÈ</b>	394 →	Bianco 01 Testa di moro 10 Topo 12	<b>VEGA (VELLUTO/VELVET)</b>
392 →	429.011 429.031 429.032 429.052 429.058 429.090 429.110	01 05 07 08 09 10 11 17 24	<b>PENELOPE</b>	398 →
	<b>GABÀN</b>	<b>LONDON</b>	396 →	103 126 129 133 135 137 139 144 300 301 302 303
392 →	1 5 7 10 13 5403	394 →	1700 1705 1710 1722 1724 1760 1762 1779	<b>PIQUÈ</b>
	<b>GIANO</b>	<b>LOOP</b>	<b>PIQUÈ</b>	396 →
393 →	3 Lighter side 3 Darker side 7 Lighter side 7 Darker side 9 Lighter side 9 Darker side	394 →	1 Perla 3 Ebano	<b>SCOTTISH</b>
		<b>MELANGE</b>	396 →	20 Light Camel 31 Light Blue 33 Light Grey
		395 →	<b>SHINE (VELLUTO/VELVET)</b>	396 →
		4 Agata 5 Lapislazzuli 6 Argento 7 Rame	397 →	Silver Beige Forest Black Iris Starry Blue
		<b>MILANO</b>		
		395 →		
		03 05 10		

## Fabric Barkley

CATEGORY B

87%PES - 13%LI

003 Perla



027 Lichene

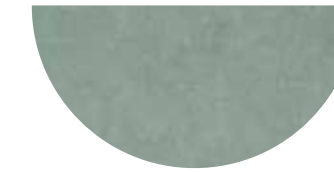

029 Topo



30 Testa di moro



37 Avio



## Fabric Bouclè

CATEGORY B

44%CO - 21%PC - 20%PL - 15%WO

101

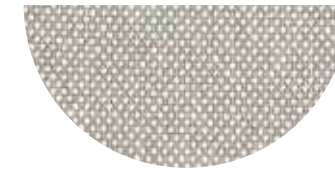

102

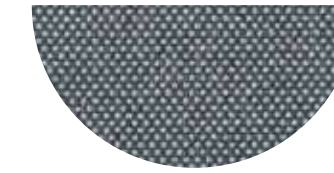

103

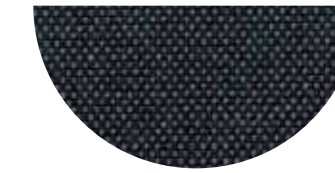

104

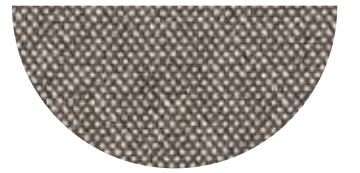

105





# Fabric Damiè

CATEGORY B  
47% CO - 18% LI - 35% VI

429.011



429.031

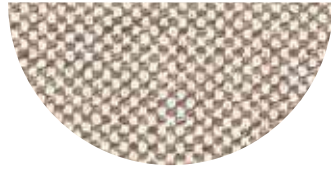

429.032



429.052



429.058

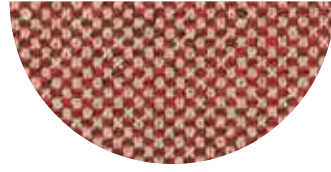

429.090



429.110

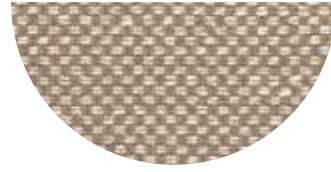

# Fabric Gabàn

CATEGORY B  
45% CO - 43% WV - 3% PA - 1% WP - 8% AF

1



5



7



10

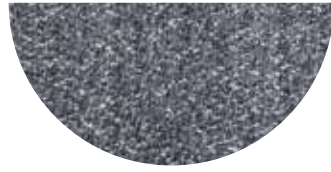

13

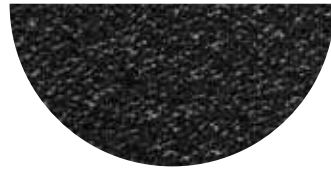

5403

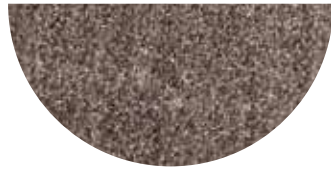

# Fabric Giano

CATEGORY A  
76% WO - 15% PL - 6% PA - 3% AF

393

3 lighter side



3 darker side



7 lighter side



7 darker side



9 lighter side

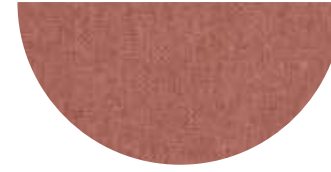

9 darker side

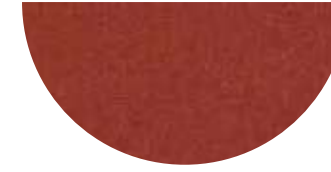

# Fabric Guatemala

CATEGORY B  
76% LI - 24% CO

Bianco



Ecrù

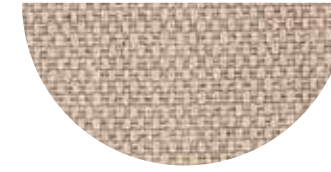

Grigio



Castoro

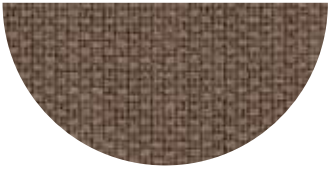

Sughero

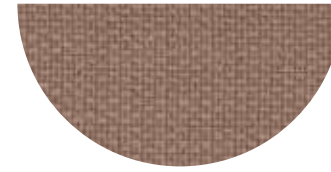

Piombo

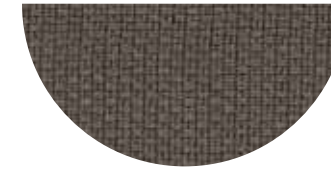

Lavagna



# Fabric Hermoso

CATEGORY B  
37% LI - 19% CO - 44% VI

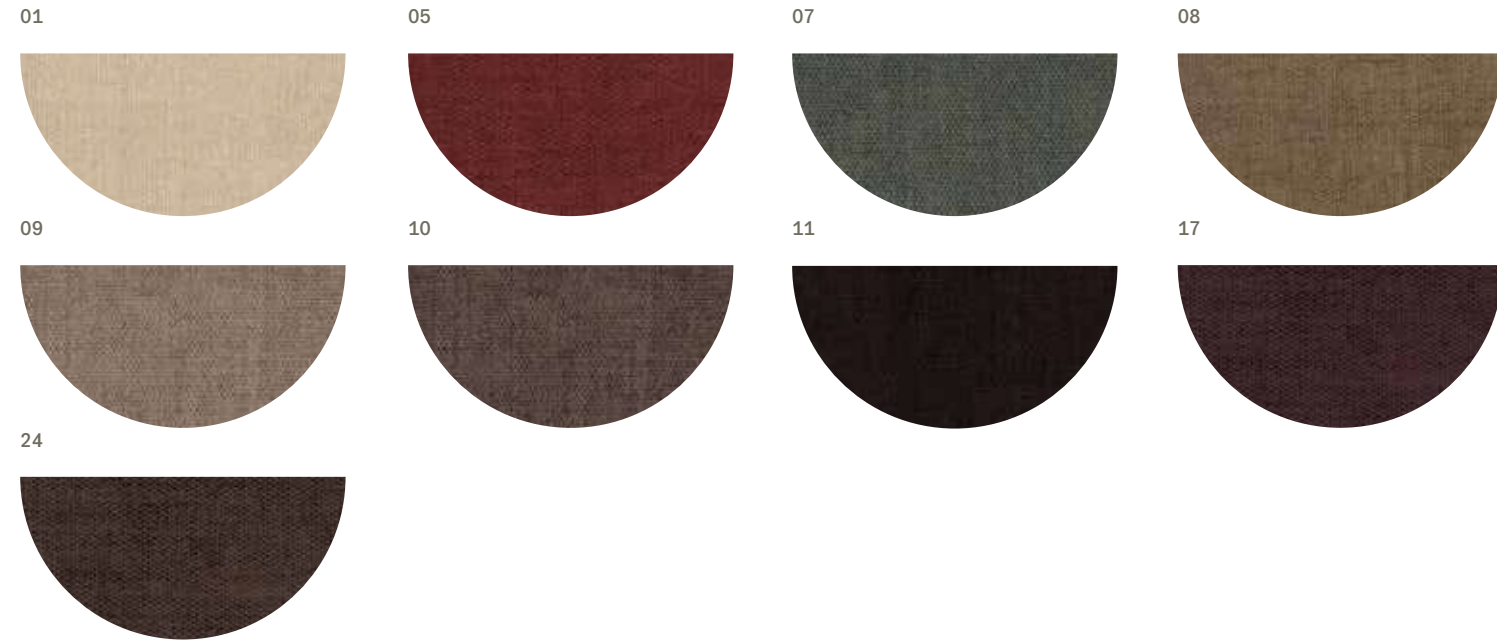

# Fabric London

CATEGORY A  
15% CO - 44% LI - 12% VI - 25% PC - 4% PL

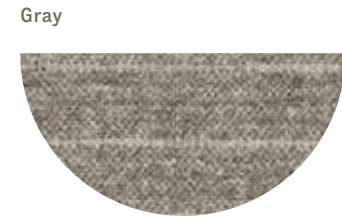

# Fabric Loop

CATEGORY B  
45% CO - 15% WO - 13% AC - 19% VI - 8% NY

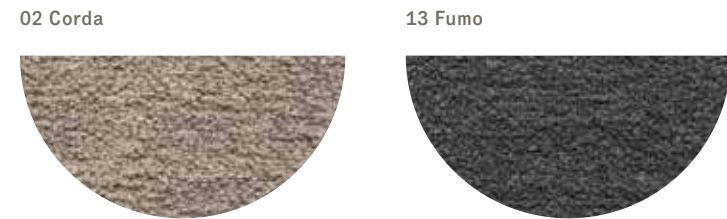

# Fabric Melange

CATEGORY B  
22% VI - 25% PC - 21% PL - 17% CO - 12% LI - 3% WO

395

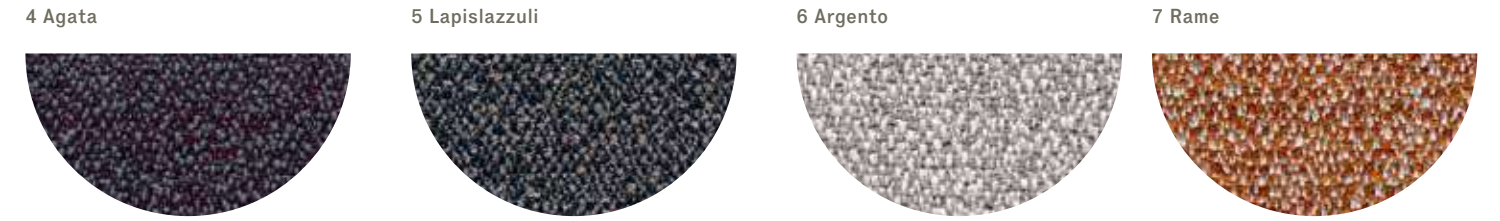

# Fabric Milano

CATEGORY B  
64% VI - 15% PL - 11% CO - 10% LI



# Fabric Nouveau

CATEGORY B  
65% CO - 10% LI - 15% VI - 10% PA



# Fabric Paltò

CATEGORY B  
70% VI - 30% LI





# Fabric Penelope

CATEGORY B  
70% VI - 30% LI

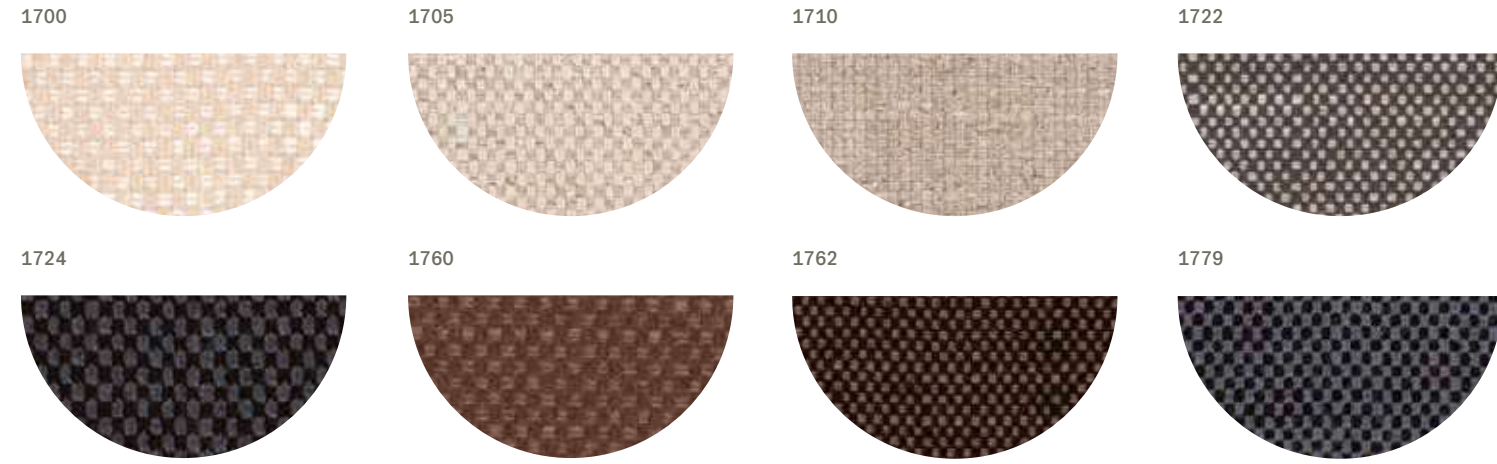

# Fabric Piquè

CATEGORY A  
70% CO - 30% LI

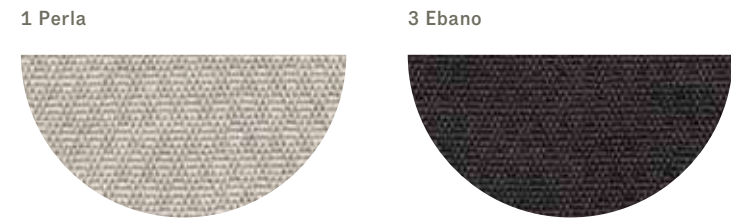

# Fabric Scottish

CATEGORY B  
30% VI - 30% - CO - 20% LI - 20% WO



# Fabric Shine

CATEGORY B  
56% CO - 44% VI

397

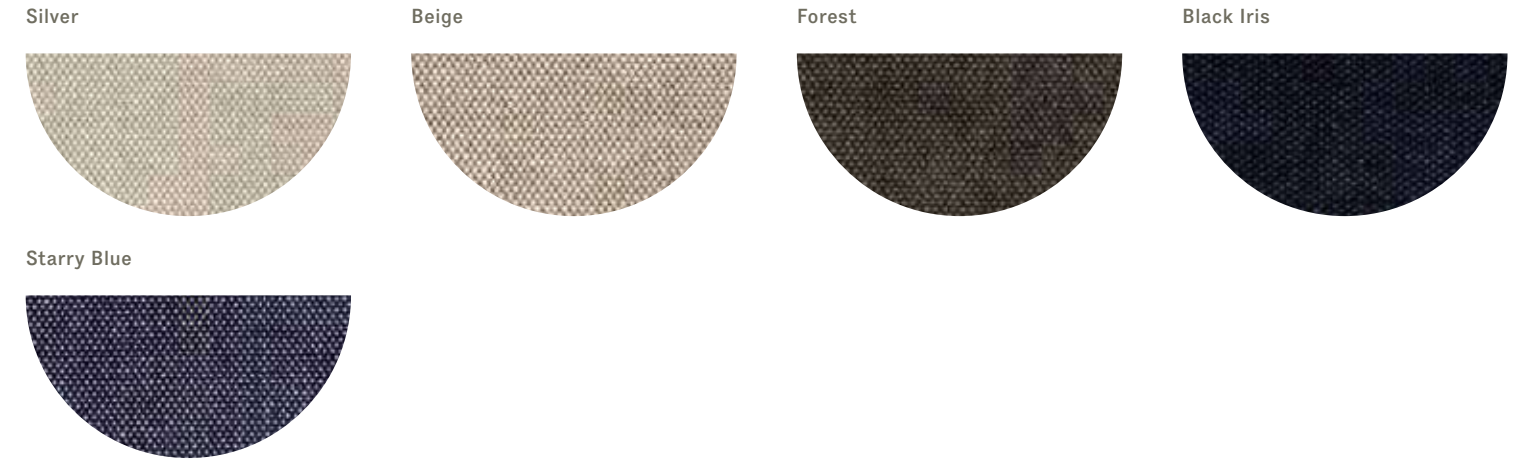

# Fabric Twill

CATEGORY B  
60%CO - 40%LI

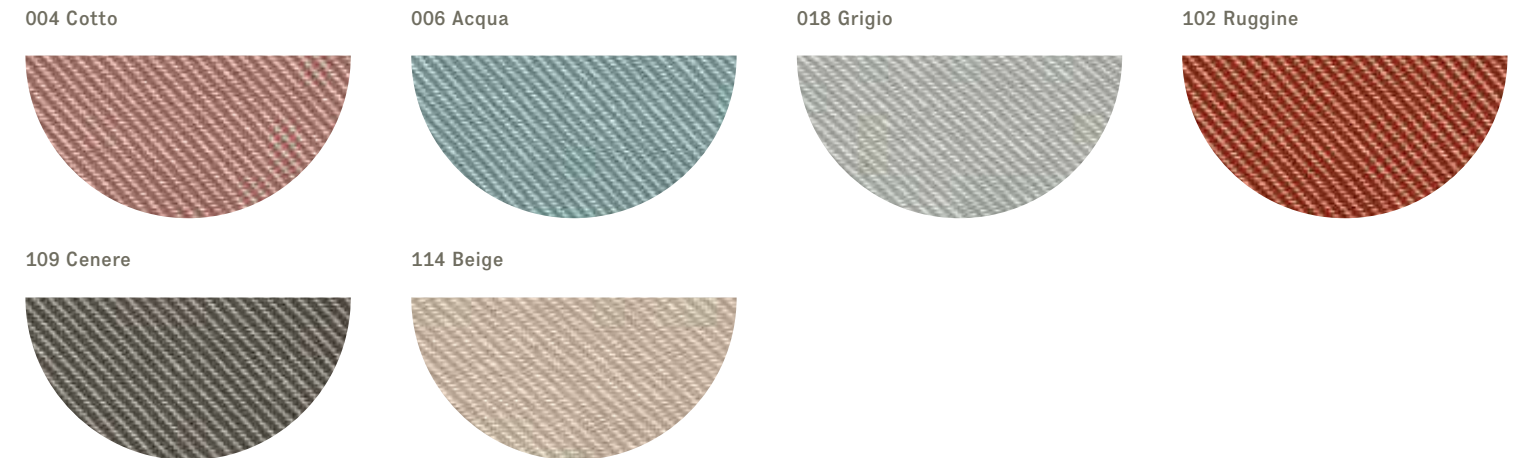

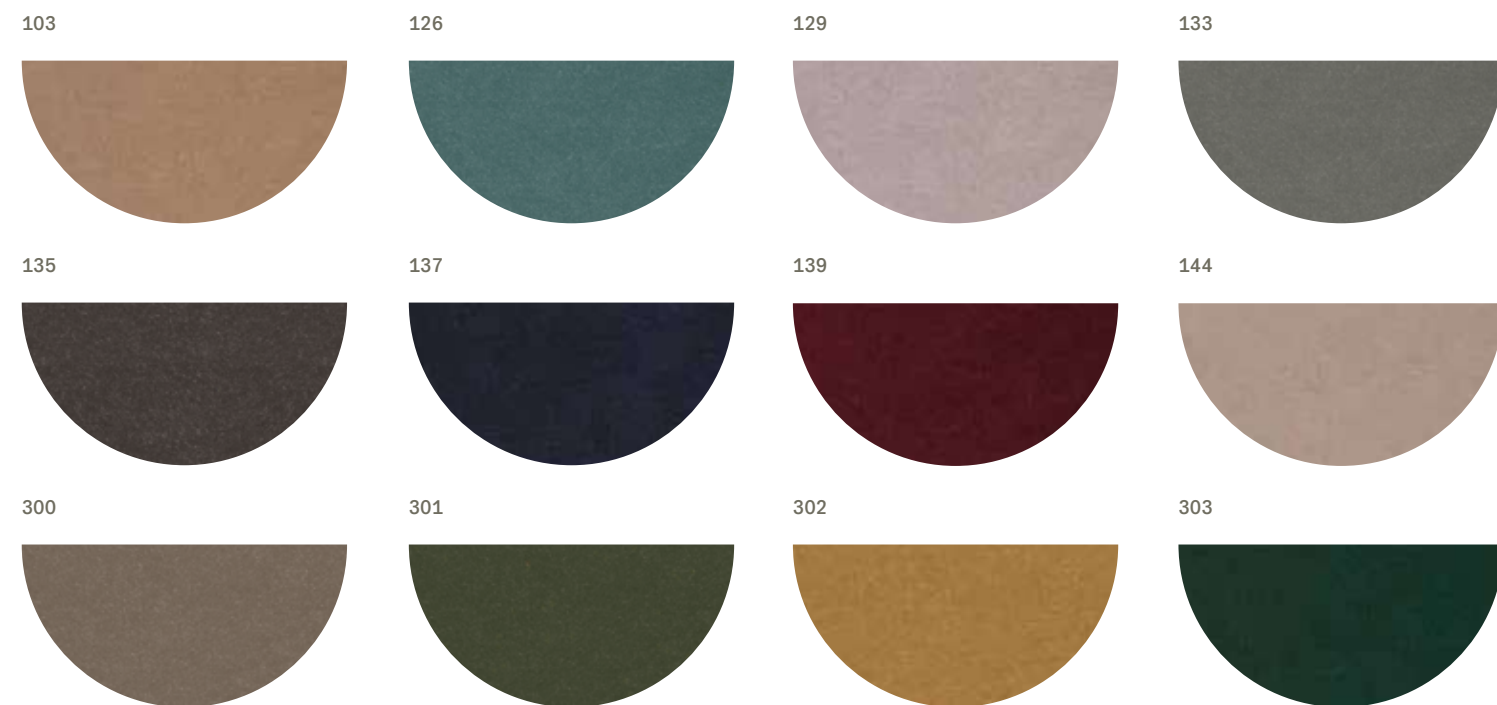

## Woods / Marbles / Stones / Fenix<sup>®</sup> / Ginger Ale shell

### WOODS

- 400 03 American walnut
- 05 Dark walnut stained beechwood
- 08 Extra light solid beech wood
- 11 Black lacquered wood
- 12 Black lacquered ash, with visible wood grain
- 20 Beech wood in a wenge stain
- 21 White lacquered ash, with visible wood grain
- 23 Oak in a wenge stain
- 26 Natural oak
- 27 Ash-tinted oak
- 29 Canaletto walnut veneer
- 30 Oak in a walnut stain
- 32 Ash in a wenge stain (solid wood)
- 33 Wengé stained glazed oak
- 35 Milk
- 39 Graphite
- 40 Natural ash
- 41 Dark brown walnut
- 46 Ash in an open-pore teak stain
- 48 Ash in a wenge stain
- 56 Tobacco oak with a matte finish
- 57 Lead oak with a matte finish
- 58 Tobacco oak with a glossy finish
- 59 Lead oak with a glossy finish
- 61 Moka ash
- 62 Ash in a havana stain
- 68 Ash in an ebony stain
- 70 Natural oak TW
- 71 Medium oak TW

### MARBLES

- 402 Brilliant Calacatta gold Marble
- Semi-brilliant Calacatta gold Marble
- Brilliant Arabescato venato Marble
- Semi-brilliant Arabescato venato Marble
- Brilliant Emperador Marble
- Brilliant Fior di Pesco Marble
- Semi-brilliant Fior di Pesco Marble
- Natural glossy finish Nero Pagoda Marble
- Brilliant Marquinia Marble
- Semi-brilliant Nero Marquinia Marble
- Nero Pagoda Marble al posto di Naturally glossy finish Nero Pagoda Marble

### STONES

- 403 Pietra Serena
- Ligurian slate
- White Porphyry
- Valcamonica Porphyry

### FENIX<sup>®</sup> NTMR

- 403 Nero Ingo (Black)
- Grigio Londra (Grey)

### SHELL COLOURS

- 403 Cement
- Anthracite



## FRASSINO / ASH

12 Black lacquered ash with visible wood grain



32 Ash in a wengè stain (solid wood)



21 White lacquered ash with visible wood grain



40 Natural ash



46 Ash in an open-pore teak stain



48 Ash in a wengè stain



61 Moka ash



62 Ash in havana stain



68 Ash in an ebony stain



## NOCE / WALNUT

03 American walnut



29 Canaletto walnut veneer



41 Dark brown walnut veneer



## FAGGIO / BEECHWOOD

05 Dark walnut stained beechwood



20 Beech wood in a wengè stain

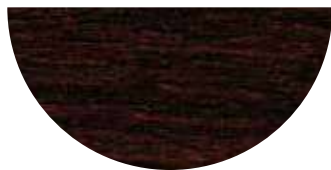

08 Extra light solid beech wood



## ROVERE / OAK

23 Oak in a wengè stain



26 natural oak



27 Ash-tinted oak



30 Oak in a walnut stain



33 Wengé stained glazed oak



56 Tobacco oak with a matte finish



57 Lead oak with a matte finish



58 Tobacco oak with a glossy finish



59 Lead oak with a glossy finish



## TECNO-WOOD

70 Light oak TW



71 Medium oak TW



## ALTRI / OTHERS

11 Black lacquered wood



35 Milk



39 Graphite



## I MARMI / MARBLES

Brilliant Calacatta gold marble



Semi-brilliant Calacatta gold marble



Brilliant Arabescato Venato marble

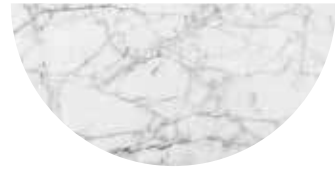

Semi-brilliant Arabescato Venato marble

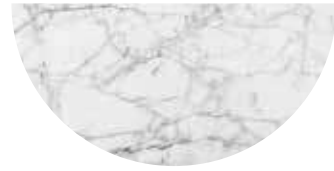

Semi-brilliant Fior di Pesco marble

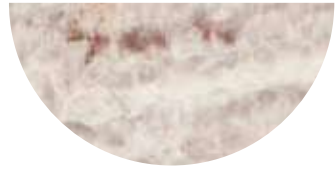

Brilliant Fior di Pesco marble

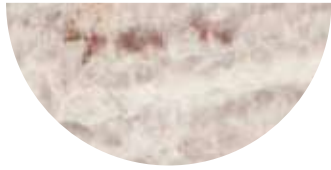

Brilliant Emperador marble



Nero Pagoda marble



Brilliant Marquinia marble



Semi-brilliant Marquinia marble

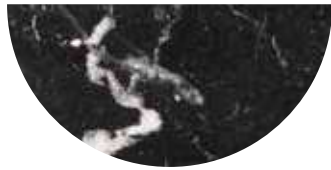

## LE PIETRE / STONES

Pietra Serena



Ligurian Slate



White Porphyry

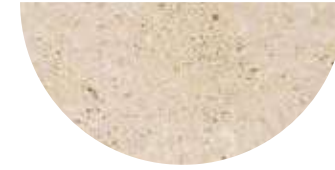

Valcamonica Porphyry



## FENIX<sup>®</sup> NTMR

Nero Ingo (Black)



Grigio Londra (Grey)

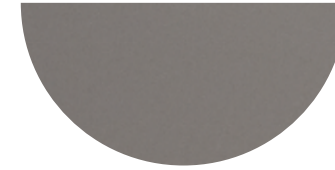

## SHELL COLOURS

Cement



Anthracite





1013639 — 2000 — 11/21

